

TEKTRONIX®

465 OSCILLOSCOPE

SERVICE

INSTRUCTION MANUAL

NOTICE

VERTICAL OUTPUT AMPLIFIER board modifications have been made on all 465's with B04- serial numbers and up. Information concerning this change can be found at the rear of this manual under Change Information. Sections of this manual affected by this modification include the CIRCUIT DESCRIPTION, CALIBRATION PROCEDURES, DIAGRAMS, ELECTRICAL AND MECHANICAL PARTS LISTS.

M20,159/573

TEKTRONIX®

465 OSCILLOSCOPE

SERVICE

INSTRUCTION MANUAL

Tektronix, Inc.
P.O. Box 500
Beaverton, Oregon 97005

Serial Number _____

TABLE OF CONTENTS

| | | |
|------------------|------------------------------------|-------------|
| SECTION 1 | 465 SPECIFICATIONS | Page |
| | Introduction | 1-1 |
| | Vertical Deflection System | 1-1 |
| | Triggering | 1-1 |
| | Horizontal Deflection System | 1-2 |
| | X-Y Operation | 1-3 |
| | Calibrator | 1-3 |
| | Z Axis Input | 1-3 |
| | Signal Outputs | 1-3 |
| | Power Source | 1-3 |
| | Cathode-Ray Tube | 1-3 |
| | Supplemental Information | |
| | General | 1-3 |
| | Vertical Deflection System | 1-3 |
| | Triggering | 1-4 |
| | Horizontal Deflection System | 1-4 |
| | Calibrator | 1-4 |
| | External Z Axis Input | 1-4 |
| | Output Signals | 1-4 |
| | Cathode-Ray Tube | 1-4 |
| SECTION 2 | OPERATING INFORMATION | |
| | Introduction | 2-1 |
| | Instrument Repackaging | 2-1 |
| | Operating Voltage | 2-1 |
| | Controls And Connectors | |
| | General | 2-2 |
| | Cathode-Ray Tube (CRT) and Display | 2-2 |
| | Vertical Deflection System | 2-2 |
| | A and B Triggering | 2-4 |
| | A and B Sweep | 2-5 |
| | Calibrator and Power | 2-6 |
| | Rear Panel | 2-6 |
| | Obtaining Basic Displays | |
| | Introduction | 2-6 |
| | Normal Sweep Display | 2-6 |
| | Magnified Sweep Display | 2-7 |
| | Delayed Sweep Display | 2-7 |
| | Mixed Sweep Display | 2-7 |
| | X-Y Display | 2-7 |
| SECTION 3 | CIRCUIT DESCRIPTION | |
| | Introduction | 3-1 |
| | Digital Logic | 3-1 |
| | Block Diagram | |
| | General | 3-1 |
| | Channel 1 Preamp | |
| | General | 3-3 |
| | Input Coupling | 3-3 |
| | Input Attenuator | 3-4 |
| | Scale-Factor Switching Circuit | 3-4 |
| | Source Follower Stage | 3-4 |
| | First Cascode Amplifier Stage | 3-4 |
| | Second Cascode Amplifier Stage | 3-4 |
| | Third Cascode Amplifier Stage | 3-5 |
| | Channel 2 Preamp | |
| | General | 3-5 |
| | Second Cascode Amplifier | 3-5 |
| | Third Cascode Amplifier | 3-6 |

TABLE OF CONTENTS (cont)

| SECTION 3 | CIRCUIT DESCRIPTION (cont) | Page |
|-----------|---------------------------------------|------|
| | Vertical Switching Circuit | |
| | General | 3-6 |
| | Diode Gates | 3-6 |
| | Switching Multivibrator | 3-7 |
| | Delay-Line Driver | 3-8 |
| | Reference Feedback Amplifier | 3-8 |
| | Normal Trigger Pickoff Amplifier | 3-8 |
| | Vertical Output Amplifier | |
| | General | 3-8 |
| | Delay Line | 3-9 |
| | Output Amplifier | 3-9 |
| | A and B Trigger Generators | |
| | General | 3-9 |
| | Trigger Source | 3-9 |
| | Trigger Coupling | 3-9 |
| | Input Source Follower | 3-9 |
| | Paraphase Amplifier | 3-9 |
| | Tunnel Diode Driver | 3-10 |
| | A And B Sweep Generators | |
| | General | 3-10 |
| | Disconnect Amplifier | 3-10 |
| | Sawtooth Sweep Generator | 3-11 |
| | Output Buffer Amplifier | 3-11 |
| | Sweep Start Amplifier | 3-11 |
| | Logic Multivibrator | 3-11 |
| | B Sweep Generator Differences | 3-11 |
| | Sweep And Z Axis Logic Circuit | |
| | General | 3-11 |
| | A Sweep Gate | 3-11 |
| | B Sweep Gate | 3-12 |
| | Sweep Control Integrated Circuit | 3-12 |
| | A Sweep Holdoff Amplifier | 3-13 |
| | B Sweep Holdoff Amplifier | 3-13 |
| | A Sweep Z-Axis Gate | 3-13 |
| | B Sweep Z-Axis Gate | 3-13 |
| | +A GATE And +B GATE Emitter Followers | 3-13 |
| | B Sweep Latch | 3-14 |
| | Horizontal Amplifier | |
| | General | 3-14 |
| | X-Axis Amplifier | 3-14 |
| | Input Paraphase Amplifier | 3-15 |
| | Gain Setting Amplifier | 3-15 |
| | Output Amplifier | 3-15 |
| | CRT Circuit | |
| | General | 3-15 |
| | High-Voltage Oscillator | 3-16 |
| | High-Voltage Regulator | 3-16 |
| | High-Voltage Rectifiers and Output | 3-17 |
| | CRT Control Circuits | 3-17 |
| | Z-Axis Amplifier | 3-17 |
| | DC Restorer Circuit | 3-17 |
| | Calibrator | |
| | General | 3-18 |
| | Multivibrator | 3-18 |
| | Output Amplifier | 3-18 |
| | A Trigger View Amplifier | |
| | General | 3-18 |
| | Amplifier | 3-18 |

TABLE OF CONTENTS (cont)

| SECTION | DESCRIPTION (cont) | Page |
|---------------------------------|--|------|
| SECTION 3 | CIRCUIT DESCRIPTION (cont) | |
| | Low-Voltage Power Supply | |
| | General | 3-19 |
| | Power Input | 3-20 |
| | Secondary Circuit | 3-20 |
| | Fan Motor Circuit | |
| | General | 3-20 |
| SECTION 4 | MAINTENANCE | |
| | Cabinet Removal | 4-1 |
| | Preventive Maintenance | |
| | General | 4-1 |
| | Cleaning | 4-1 |
| | Lubrication | 4-2 |
| | Transistors Checks | 4-2 |
| | Recalibration | 4-2 |
| | Corrective Maintenance | |
| | General | 4-2 |
| | Obtaining Replacement Parts | 4-2 |
| | Soldering Techniques | 4-3 |
| | Component Replacement | 4-3 |
| | Recalibration After Repair | 4-5 |
| Instrument Repackaging | 4-6 | |
| SECTION 5 | CALIBRATION | |
| | Calibration Interval | 5-1 |
| | TEKTRONIX Field Service | 5-1 |
| | Using This Procedure | 5-1 |
| | Test Equipment Required | 5-1 |
| | Performance Check | |
| | Vertical System Check | 5-6 |
| | Trigger System Check | 5-11 |
| | Horizontal System Check | 5-13 |
| | Short-Form Calibration | |
| | Power Supplies And Display | 5-16 |
| | Vertical System | 5-17 |
| | Trigger System | 5-19 |
| | Horizontal System | 5-21 |
| | Detailed Calibration | |
| | Power Supply | 5-27 |
| | Display & Z-Axis | 5-28 |
| Vertical System | 5-30 | |
| Trigger System | 5-43 | |
| Horizontal System | 5-53 | |
| Calibrator, Gates, & Ext Z-Axis | 5-60 | |
| SECTION 6 | ELECTRICAL PARTS LIST | |
| SECTION 7 | DIAGRAMS & CIRCUIT BOARD ILLUSTRATIONS | |
| SECTION 8 | MECHANICAL PARTS LIST & ILLUSTRATIONS | |
| CHANGE INFORMATION | | |

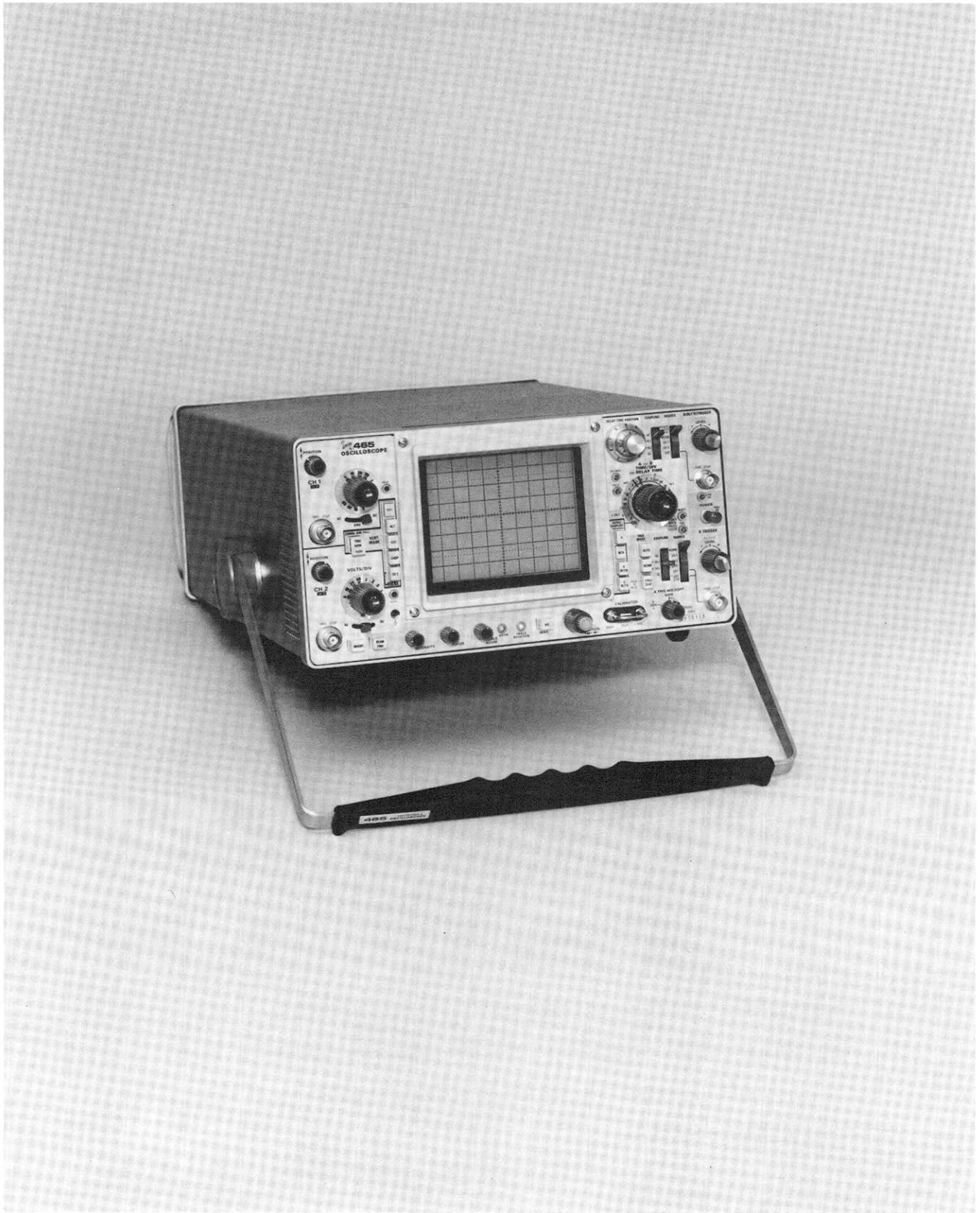

Fig. 1-1. 465 Oscilloscope.

465 SPECIFICATIONS

Introduction

The 465 Oscilloscope is a wide-band, portable oscilloscope designed to operate in a wide range of environmental conditions. The instrument is light in weight and compact of design for ease of transportation, yet capable of performance necessary for accurate high-frequency measurements. The dual-channel, DC-to-100 megahertz vertical deflection system provides calibrated deflection factors from 5 millivolts to 5 volts/division. The bandwidth limiting switch reduces interference from signals above about 20 megahertz for viewing low-frequency, low-level signals.

The trigger circuits provide stable sweep triggering to beyond the bandwidth of the vertical deflection system. Separate controls are provided to select the desired mode of triggering for the A and B sweeps. The A sweep can be operated in one of three modes: automatic triggering, normal triggering, or single sweep. A variable trigger holdoff control provides the ability for A sweep to trigger stably on aperiodic signals or complex digital words. The horizontal deflection system has calibrated sweep rates from 0.5

second to 0.05 microsecond/division. A X10 magnifier increases each sweep rate by a factor of 10 to provide a maximum sweep rate of 5 nanoseconds/division in the 0.05 μ s position. The delayed and mixed sweep features allow the start of the B sweep to be delayed a selected amount from the start of A sweep to provide accurate relative-time measurements. Calibrated X-Y measurements can be made with Channel 2 providing the vertical deflection and Channel 1 providing the horizontal deflection (TIME/DIV switch fully counterclockwise and VERT MODE switch to CH 2). The regulated DC power supplies ensure that instrument performance is not affected by variations in line voltage and frequency. Maximum power consumption of the instrument is approximately 75 watts.

The following instrument specifications apply over an ambient temperature range of -15°C to $+55^{\circ}\text{C}$ unless otherwise specified. Warm-up time for specified accuracies is 20 minutes. The calibration procedure given in section 5, if performed completely, will allow an instrument to meet the electrical characteristics listed below.

VERTICAL DEFLECTION SYSTEM

Deflection Factor

Calibrated range is from 5 millivolts to 5 volts per division in 10 steps in a 1-2-5 sequence. Accuracy is within 3%. Uncalibrated VAR control provides deflection factors continuously variable between the calibrated settings, and extends deflection factor to at least 12.5 volts per division in the 5 volts/div position.

Frequency Response

Bandwidth in both Channel 1 and Channel 2 is DC to at least 100 megahertz. Risetime is 3.5 nanoseconds or less. The AC-coupled lower -3 dB point is 10 hertz or less (1 hertz or less when using a 10X probe). Vertical system bandwidth with the BW LIMIT pushbutton pulled is approximately 20 megahertz.

Chopped Mode Repetition Rate

Approximately 250 kilohertz.

Input Resistance And Capacitance

One megohm within 2% paralleled by approximately 20 picofarads.

Maximum Input Voltage

DC coupled: 250 V (DC + Peak AC) or 500 V P-P AC at 1 kHz or less.

AC coupled: 500 V (DC + Peak AC) or 500 V P-P AC at 1 kHz or less.

Cascaded Operation (CH 1 VERT SIGNAL OUT Connected to CH 2 OR Y)

Bandwidth is DC to at least 50 MHz with a sensitivity of at least 1 mV/division.

TRIGGERING

Sensitivity

DC Coupled: 0.3 division internal or 50 millivolts external from DC to 25 megahertz, increasing to 1.5 divisions internal or 150 millivolts external at 100 megahertz.

AC Coupled: 0.3 division internal or 50 millivolts external from 60 hertz to 25 megahertz, increasing to 1.5 divisions internal or 150 millivolts external at 100 megahertz. Attenuates all signals below about 60 hertz.

Specifications—465

LF REJ Coupled: 0.3 division internal or 100 millivolts external from 50 kilohertz to 25 megahertz, increasing to 1.5 divisions internal or 300 millivolts external at 100 megahertz. Blocks DC and attenuates all signals below about 50 kilohertz.

HF REJ Coupled: 0.3 division internal or 50 millivolts external from 60 hertz to 50 kilohertz. Blocks DC and attenuates all signals below about 60 hertz and above about 50 kilohertz.

Trigger Jitter

0.5 nanosecond or less at 5 nanoseconds/division with 100 megahertz applied (X10 MAG on).

External Trigger Input

Maximum input voltage is 250 V DC + peak AC or 250 V P-P AC (1 kilohertz or less). Input resistance is 1 megohm within 10%.

LEVEL Control Range

EXT: At least + and - 2 volts, 4 volts peak to peak.

EXT ÷10: At least + and - 20 volts, 40 volts peak to peak.

HORIZONTAL DEFLECTION SYSTEM

Calibrated Sweep Range

A Sweep: from 0.5 second/division to 0.05 microsecond/division in 22 steps in a 1-2-5 sequence. X10 MAG extends maximum sweep rate to 5 nanoseconds/division.

B Sweep: from 50 milliseconds/division to 0.05 microsecond/division in 19 steps in a 1-2-5 sequence. X10 MAG extends maximum sweep rate to 5 nanoseconds/division.

Calibrated Sweep Accuracy

Unmagnified sweep accuracy is ±2% from +20°C to +30°C (+68°F to +86°F) and ±3% from -15°C to +20°C and +30°C to +55°C (+5°F to +68°F and +86°F to +131°F). For the same temperature ranges, magnified sweep accuracy is ±3% and ±4% respectively. Exclude the first and last 50 ns of the 5 ns, 10 ns, and 20 ns magnified sweep rates. Accuracy specifications apply over full ten divisions unless otherwise specified.

Sweep accuracy, over any two or less division portion of the sweep, is ±5%. Exclude the first and last magnified divisions of the 5 ns and 10 ns/div magnified sweep rates. Also exclude the first and last 50 ns of the 5, 10, and 20 ns/div magnified sweep rates.

Mixed sweep accuracy is 2% plus the measured A sweep error when viewing the A sweep portion only. The B sweep portion retains its normal accuracy.

A Time/Division Variable Range

Provides continuously variable (uncalibrated) sweep rates between the calibrated settings of the A TIME/DIV switch. Extends the slowest A sweep rate to at least 1.25 seconds/division.

A Trigger Holdoff

Increases A sweep holdoff time by at least a factor of 10.

Delay Time And Differential Time Measurement Accuracy

| | +15°C to +35°C (+60°F to +95°F) | -15°C to +55°C (+5°F to +131°F) |
|--|------------------------------------|------------------------------------|
| Over One Or More Major Dial Division | ±1% | ±2.5% |
| Over Less Than One Major Dial Division | ±0.01 Major Dial Division | ±0.03 Major Dial Division |

Delay Time Jitter

Within 0.002% (less than one part in 50,000) of the maximum available delay time when operating on power line frequencies other than 50 Hz.

Within 0.005% (less than one part in 20,000) of the maximum available delay time when operating on 50 Hz power line frequency.

Maximum available delay time is ten times the setting of the A TIME/DIV switch.

Calibrated Delay Time (A VAR set to calibrated position)

Continuous from 5 seconds to 0.2 microsecond.

X-Y OPERATION**Sensitivity**

Same as vertical deflection system.

X Axis deflection accuracy within 4%.

Variable Range

Same as vertical deflection system.

X-Axis Bandwidth

DC to at least 4 megahertz.

Y-Axis Bandwidth

Same as vertical deflection system.

Input Resistance

Same as vertical deflection system.

Input Capacitance

Same as vertical deflection system.

Maximum Usable Input Voltage

Same as vertical deflection system.

CALIBRATOR**Output**

An approximate 1 kilohertz frequency 30 milliamperere ($\pm 2\%$), 300 millivolt ($\pm 1\%$) square-wave signal.

Z AXIS INPUT**Sensitivity**

A 5-volt peak to peak signal causes noticeable modulation at normal intensity.

Usable Frequency Range

From DC to 50 megahertz.

SIGNAL OUTPUTS**CH 1 VERT SIGNAL OUT**

Output voltage is at least 50 millivolts/division into a 1 megohm load (at least 25 millivolts/division into a 50 ohm load).

Bandwidth is from DC to at least 50 megahertz into a 50 ohm load.

Output DC level is approximately zero volts.

A and B +GATE Outputs

Output voltage is approximately 5.5 volts, positive-going.

POWER SOURCE**Line Voltages**

110, 115, 120, 220, 230, or 240 VAC (all $\pm 10\%$), depending on the settings of the Line Voltage Selector switch and the Regulating Range Selector assembly, with a line frequency of 48 to 440 hertz. Maximum power consumption is 75 watts at 115 VAC, 60 hertz.

CATHODE-RAY TUBE**Graticule Area**

Eight by ten centimeters.

Phosphor

P31 is the standard phosphor with P11 offered as an option.

SUPPLEMENTAL INFORMATION**General**

The supplemental information listed here represents limits that, when met, ensure optimum instrument operation. They are, however, not instrument specifications but are intended to be used only as maintenance or operational aids.

VERTICAL DEFLECTION SYSTEM**Low-Frequency Linearity**

There should be no more than 0.1 division of compression or expansion of a two-division signal at center screen when the signal is positioned to the upper and lower extremes of the CRT graticule area.

Bandwidth Limiter Bandwidth

The -3 dB point should be between 15 and 25 megahertz.

Step Response Aberrations

There should be less than +3%, -3%, or a total of 3% peak to peak aberration on a positive-going step. Add 2% when checking a negative-going step. Position-effect should not cause total aberrations to be more than +5%, -5%, or a total of 5% peak to peak.

Common-Mode Rejection Ratio

At least 10:1 at 20 megahertz for common mode signals of 6 divisions or less with vertical gain adjusted for best CMRR at 50 kilohertz.

Step Attenuator Balance

Adjustable to 0.2 division or less of trace shift when switching between adjacent deflection factors.

Trace Shift As Variable Is Rotated

Adjustable to one division or less.

INVERT Trace Shift

Two divisions or less when switching from normal to inverted.

Input Gate Current

0.5 nanoampere or less (0.1 division of deflection at 5 mV/div) from +20°C to +30°C. Four nanoamperes or less (0.8 division of deflection at 5 mV/div) from -15°C to +55°C.

Channel Isolation

At least 100:1 at 25 megahertz.

Position Control Range

Twelve divisions up and twelve divisions down from graticule center.

TRIGGERING

External Trigger Input Capacitance

Twenty picofarads within 30%.

HORIZONTAL DEFLECTION SYSTEM

A Sweep Length

10.5 to 11.5 divisions.

Magnifier Registration

There should be 0.2 division or less difference at graticule center when switching from MAG on to MAG off.

Position Control Range

Should be able to position the start of the sweep to the right of graticule center, and the end of the sweep to the left of graticule center.

Phase Difference Between X And Y Axes Amplifiers

Typically 3° or less from DC to 50 kilohertz.

CALIBRATOR

Repetition Rate

Repetition rate accuracy is typically within 25%.

Output Resistance

Approximately 9.4 ohms.

EXTERNAL Z AXIS INPUT

Maximum Input Voltage

Voltages applied to the EXT Z AXIS INPUT connector should be limited to less than 100 volts DC plus peak AC or 100 volts peak to peak AC at 1 kilohertz or less.

OUTPUT SIGNALS

Output Resistance

Output resistance of the CH 1 VERT SIG OUT connector is $\approx 50 \Omega$.

Output resistance of +A and +B GATE outputs is $\approx 500 \Omega$.

CATHODE-RAY TUBE

Resolution

Typically at least 15 lines per division horizontally and vertically.

Geometry

0.1 division or less of tilt or bowing.

Raster Distortion

0.1 division or less.

Nominal Accelerating Potential

Approximately 18,500 volts.

OPERATING INFORMATION

Introduction

This section of the manual is intended to allow the operator to become familiar with the instrument power requirements, functions of controls and connectors, and how to obtain a few basic displays. For more complete operating information, refer to the 465 Operators Handbook.

Instrument Repackaging

If this instrument is to be shipped for long distances by commercial means of transportation, it is recommended that it be repackaged in the original manner for maximum protection. The original shipping carton can be saved and used for this purpose. Fig. 5 in the Mechanical Parts List illustrates how to repackage the 465 and gives the part number for the packaging components. New shipping cartons can be obtained from Tektronix, Inc. Contact your local TEKTRONIX Field Office or representative.

Operating Voltage

CAUTION

This instrument is designed for operation from a power source with its neutral at or near earth (ground) potential with a separate safety-earth conductor. It is not intended for operation from two phases of a multi-phase system, or across the legs of a single-phase three-wire system.

This instrument can be operated from either a 115-volt or 230-volt nominal line voltage source, 48 to 440 hertz. The Line Voltage Selector switch in the instrument converts the instrument from one nominal operating voltage to the other. The Regulating Range Selector assembly on the instrument rear panel selects one of three regulating ranges for each nominal line voltage; it also contains the line fuse for overload protection. To select the correct nominal line voltage and regulating range, proceed as follows:

1. Disconnect the instrument from the power source.

2. To convert from 115-volts nominal to 230-volts nominal line voltage, set the selector switch to the 230 volts position (toward the rear of the instrument). Change the line-cord plug to match the power source or use a 115-to-230 volt adapter.

NOTE

Color-coding of the cord conductors is as follows (in accordance with National Electrical Code):

| | |
|------------------------------|--|
| <i>Line</i> | <i>Black</i> |
| <i>Neutral</i> | <i>White</i> |
| <i>Safety earth (ground)</i> | <i>Green (or green with yellow tracer)</i> |

3. To change regulating ranges, loosen the two captive screws which hold the cover onto the Regulating Range Selector assembly, then pull to remove the cover.

4. Pull out the range selector switch bar (see Fig. 2-1). Slide the bar to the desired position and plug it back in. Select a range which is centered about the average line voltage to which the instrument is to be connected (see Table 2-1).

TABLE 2-1
Regulating Ranges

| Range Selector Switch Position | Regulating Range | |
|---------------------------------|-------------------|-------------------|
| | 115-Volts Nominal | 230-Volts Nominal |
| Lo (switch bar in bottom holes) | 99 to 121 volts | 198 to 242 volts |
| M (switch bar in middle holes) | 104 to 126 volts | 208 to 252 volts |
| HI (switch bar in top holes) | 108 to 132 volts | 216 to 264 volts |

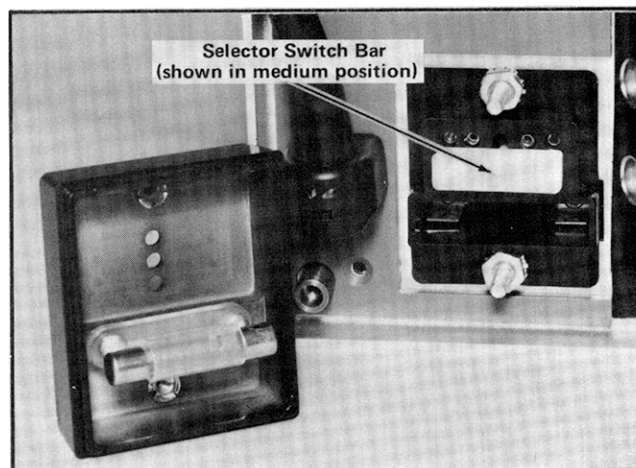

Fig. 2-1. Power supply regulating range selector.

Operating Information—465

5. Re-install the cover and tighten the two captive screws.

6. Before applying power to the instrument, check that the line voltage selector switch and the indicating tab on the Regulating Range Selector assembly are in the correct position for the desired nominal line voltage and regulating range.



This instrument may be damaged if operated with the line voltage selector switch or the Regulating Range Selector assembly set to incorrect positions for the line voltage applied.

The 465 is designed to be used with a three-wire AC power system. If a three-to two-wire adapter is used to connect this instrument to a two-wire AC power system, be sure to connect the ground lead of the adapter to earth (ground). Failure to complete the ground system may allow the chassis of this instrument to be elevated above ground potential and pose a shock hazard.

The feet on the rear panel provide a convenient cord wrap to store the power cord when not in use.

CONTROLS AND CONNECTORS

General

The major controls and connectors for operation of the 465 are located on the front panel of the instrument. A few auxiliary functions are provided on the rear panel. Fig. 2-2 shows the front and rear panels of the 465. A brief description of each control and connector is given here. More detailed operating information is given in the 465 Oscilloscope Operators Handbook.

Cathode-Ray Tube (CRT) and Display

| | |
|-------------|--|
| BEAM FIND | Compresses the display to within the graticule area, independently of display position or applied signals. |
| INTENSITY | Controls brightness of the display. |
| FOCUS | Provides adjustment for optimum display definition. |
| SCALE ILLUM | Controls graticule brightness. |

ASTIG Screwdriver adjustment used in conjunction with the FOCUS control to obtain a well-defined display. Does not require readjustment in normal use.

TRACE ROTATION Screwdriver adjustment to align the trace with the horizontal graticule lines.

Vertical Deflection System (Channel 1 & Channel 2)

POSITION Controls the vertical position of the trace. In the X-Y mode of operation, the CH 2 control positions on the Y-axis (vertically) and the Horizontal POSITION control positions on the X-axis (horizontally).

CH 1 OR X Input connector for Channel 1 deflection signals or X-axis deflection in the X-Y mode of operation.

CH 2 OR Y Input connector for Channel 2 deflection signals or Y-axis deflection in the X-Y mode of operation.

GAIN (Side Panel) Screwdriver adjustment to set the gain of the Vertical Preamp.

VOLTS/DIV Selects vertical deflection factor in a 1-2-5 sequence (VAR control must be in the calibrated detent for the indicated deflection factor).

VAR Provides continuously variable uncalibrated deflection factors between the calibrated settings of the VOLTS/DIV switch.

UNCAL Light indicates that the VAR control is not in the calibrated position.

Input Coupling (AC-GND-DC) Selects the method of coupling signal to the input of the Vertical Amplifier.

AC: Signal is capacitively coupled to the Vertical Amplifier. DC component of signal is blocked. Low-frequency limit (lower -3 dB point) is about 10 hertz.

GND: Input signal is removed and the input circuit is grounded. Does not ground the input signal.

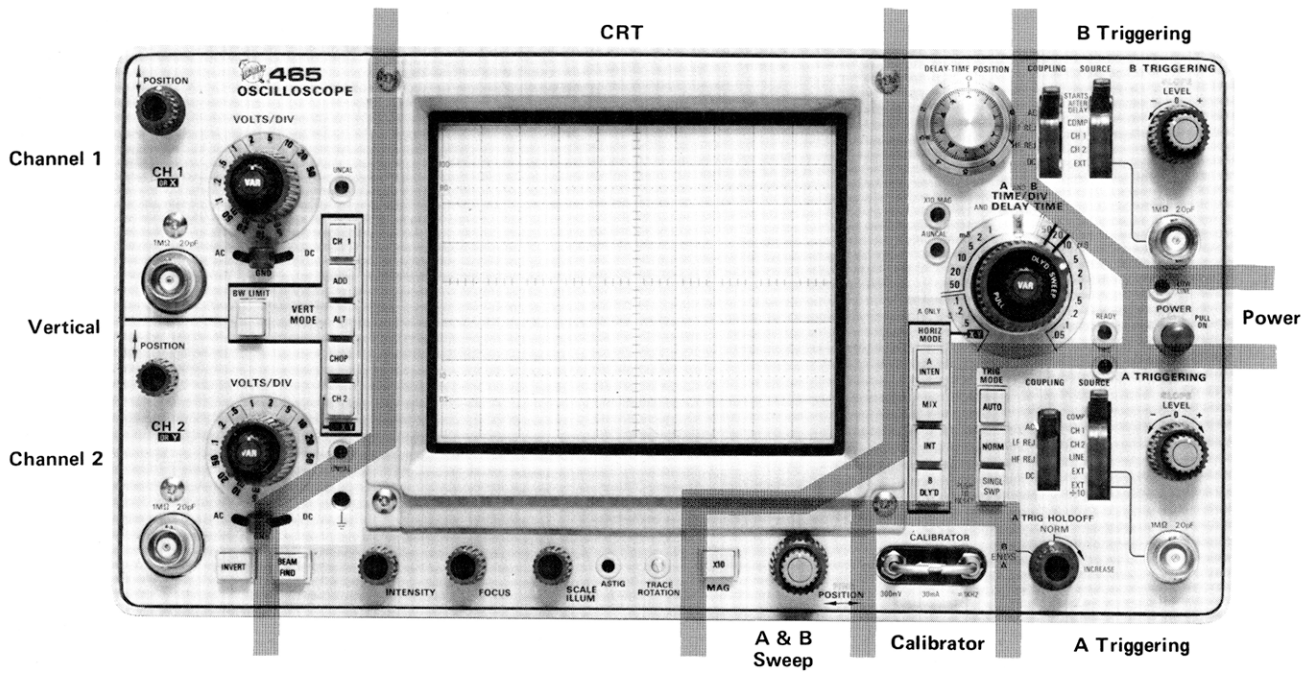

A. Front panel.

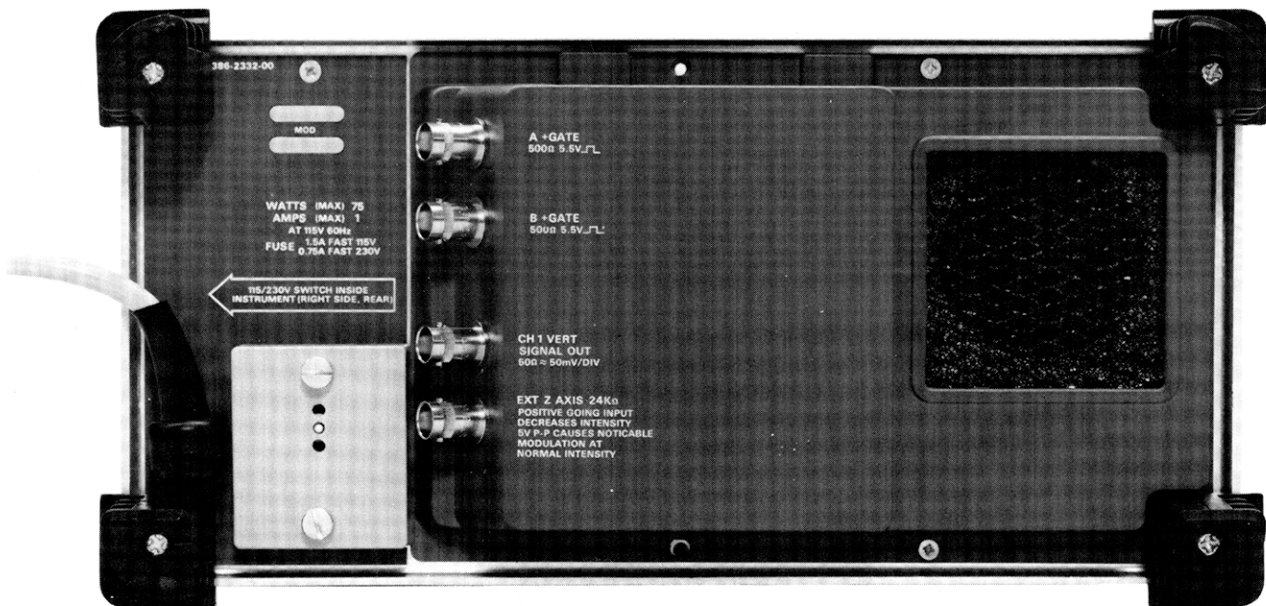

B. Rear panel.

Fig. 2-2. Front- and rear-panel controls and connectors.

| | | | |
|---|--|--------|--|
| | DC: All components of the input signal are passed to the Vertical Amplifier. | | HF REJ: Accepts signals between 60 Hz and 50 kHz. Rejects DC and attenuates all signals outside the above range. |
| 20 MHz BW/TRIG VIEW | Dual-purpose switch that, when pulled out, limits the bandwidth of the complete Vertical Deflection System to approximately 20 MHz, or when pressed causes signal present in A Trigger Generator circuit to be displayed on the CRT. | SOURCE | DC: Accepts all trigger signals from DC to 100 MHz or greater. |
| INVERT | Pushbutton switch that inverts the Channel 2 display. | | Selects source of trigger signal. |
| VERT MODE | Selects the vertical mode of operation. | | NORM: Internal trigger signal obtained from Vertical Deflection System. Actual source is signal(s) displayed on CRT. |
| | CH 1: Displays Channel 1 only. | | CH 1: A sample of the signal connected to the CH 1 OR X input connector is used as a trigger signal. |
| | ALT: Dual-trace display of signals on both channels. Display is switched between channels at the end of each sweep. | | CH 2: A sample of the signal connected to the CH 2 OR Y input connector is used as a trigger signal. |
| | ADD: Signals applied to the CH 1 OR X and CH 2 OR Y connectors are algebraically added and the sum is displayed on the CRT. The INVERT switch in Channel 2 allows the display to be CH 1 + CH 2 or CH 1 - CH 2. | | EXT: Trigger signal is obtained from signal connected to the External Trigger Input connector. |
| | CHOP: Dual-trace display of signals on both channels. Display is switched between channels at an approximate repetition rate of 250 kHz. | | EXT ÷10 (A trigger circuit only): External trigger signal is attenuated by a factor of 10. |
| | CH 2 OR X-Y: Displays Channel 2 only. Must be pushed when operating in X-Y mode. | | STARTS AFTER DELAY (B trigger circuit only): B sweep starts immediately after the delay time selected by the DELAY-TIME POSITION dial and the DELAY-TIME switch. |
| A and B Triggering (both where applicable) | | SLOPE | LINE (A trigger circuit only): Trigger signal is obtained from a sample of the line voltage applied to the instrument. |
| COUPLING | Determines the method used to couple signal to input of trigger circuits. | | Selects the slope of the trigger signal which starts the sweep. |
| | AC: Rejects DC and attenuates signals below about 60 Hz. Accepts signals above about 60 Hz. | | +: Sweep can be triggered from the positive-going portion of the trigger signal. |
| | LF REJ: Rejects DC and attenuates signals below about 50 kHz. Accepts signals above about 50 kHz. | LEVEL | -: Sweep can be triggered from the negative-going portion of the trigger signal. |
| | | | Selects the amplitude point on the trigger signal at which the sweep is triggered. |

| | | | |
|---|---|---|--|
| <p>A TRIG MODE</p> | <p>Determines the operating mode for the A Trigger Circuit.</p> <p>AUTO: With the proper trigger control settings, A Sweep can be initiated by signals that have repetition rates above about 20 hertz and are within the frequency range selected by the COUPLING switch. In the absence of an adequate trigger signal or when the trigger controls are misadjusted, the sweep free-runs to produce a reference trace.</p> <p>NORM: With the proper trigger control settings, A Sweep can be initiated by signals that are within the frequency range selected by the COUPLING switch. In the absence of an adequate trigger signal or when the trigger controls are misadjusted, there is no trace.</p> <p>SING SWP: After a sweep is displayed, further sweeps cannot be presented until the SING SWP pushbutton is pressed again. The display is triggered the same as for NORM operation using the A Triggering controls.</p> | <p>A AND B TIME/DIV AND DELAY TIME</p> | <p>A TIME/DIV switch (clear plastic outer flange) selects the sweep rate of the A sweep circuit and selects the basic delay time (to be multiplied by DELAY-TIME POSITION dial setting) for delayed-sweep operation. B TIME/DIV switch (inner dark knob) selects sweep rate of the B sweep circuit for delayed sweep operation only. VAR control must be in calibrated detent for calibrated A sweep rates.</p> |
| | | <p>VAR</p> | <p>Provides continuously variable A sweep rates between the calibrated settings of the A TIME/DIV switch. The A sweep rate is calibrated when the VAR control is fully clockwise into the calibrated detent.</p> |
| | | <p>UNCAL</p> | <p>Light that indicates when the VAR TIME/DIV control is out of the calibrated detent and the horizontal sweep rate is uncalibrated.</p> |
| | | <p>X10 MAG Indicator</p> | <p>Light that indicates when the X10 MAG is turned on.</p> |
| | | <p>READY</p> | <p>Light that indicates that A Sweep has been prepared to present a single sweep upon receipt of an adequate trigger signal.</p> |
| | | <p>HORIZ DISPLAY</p> | <p>Selects the horizontal mode of operation.</p> <p>A: Horizontal deflection provided by A Sweep. B Sweep inoperative.</p> <p>MIX: The first part of the horizontal sweep is displayed at a rate set by the A TIME/DIV switch and the latter part of the sweep at a rate set by the B TIME/DIV switch. Relative amounts of the display allocated to each of the two rates are determined by the setting of the DELAY-TIME POSITION dial.</p> <p>A INT: Displayed sweep rate determined by the A TIME/DIV switch. An intensified portion appears on the display during the B sweep time. This switch position provides a check of the duration and position of the B sweep (delayed sweep) with respect to the delaying sweep (A).</p> |
| <p>A TRIG HOLDOFF</p> | <p>Provides control of holdoff time between sweeps to obtain stable displays when triggering on aperiodic signals (such as complex digital words). Variable can increase hold-off time up to at least 10 times the holdoff time of the NORM position. In the B ENDS A position (fully clockwise), the A sweep is reset at the end of the B sweep to provide the fastest possible sweep repetition rate for delayed sweep presentations.</p> | | |
| <p>External Trigger Input (not labeled)</p> | <p>Input connectors for external trigger signals.</p> | | |
| <p>A and B Sweep</p> <p>DELAY-TIME POSITION</p> | <p>Provides variable sweep delay between 0.20 and 10.20 times the delay time indicated by the DELAY TIME switch.</p> | | |

Operating Information—465

B DLYD: Sweep rate determined by the B TIME/DIV switch with the delay time determined by the setting of the DELAY TIME (A TIME/DIV) switch and the DELAY-TIME POSITION dial.

Horizontal POSITION Positions the display horizontally.

X10 MAG Increases the displayed sweep rate by a factor of 10.

Calibrator and Power

CALIBRATOR A combination current loop and square-wave voltage output device. Provides a 30 mA square-wave current, 300 mV square-wave voltage signal with a repetition rate of approximately 1 kHz.

POWER Turns instrument power on and off.

LOW LINE Light that indicates the applied line voltage is below the lower limit of the regulating range selected by the Regulating Range Selector assembly.

Rear Panel

A +GATE Output connector providing a positive-going rectangular pulse coincident with the A sweep time.

B +GATE Output connector providing a positive-going rectangular pulse coincident with the B sweep time.

CH 1 VERT SIGNAL OUT Output connector providing a sample of the signal applied to the CH 1 input connector.

EXT Z AXIS INPUT Input connector for intensity modulation of the CRT display.

Regulating Range Selector Selects the regulating range of the internal power supplies (low, medium, high; determined by specific line voltage applied to instrument).

OBTAINING BASIC DISPLAYS

Introduction

The following instructions will allow the operator who is unfamiliar with the operation of the 465 to obtain the basic

displays commonly used. Before proceeding with these instructions, preset the instrument controls as follows:

Vertical Controls

| | |
|----------------------------|--|
| VERT MODE Switch | CH 1 |
| VOLTS/DIV Switches | Proper position determined by amplitude of signal to be applied. |
| VOLTS/DIV VAR Controls | Calibrated detent |
| Input Coupling Switches | AC |
| Vertical POSITION Controls | Midrange |
| 20 MHz BW Switch | Not limited |
| INVERT Switch | Button out |
| INTENSITY Control | Fully counterclockwise |
| FOCUS Control | Midrange |
| SCALE ILLUM Control | Midrange |

Trigger Controls (both A and B if applicable)

| | |
|------------------------|------|
| SLOPE Switch | + |
| LEVEL Control | 0 |
| SOURCE Switch | NORM |
| COUPLING Switch | AC |
| TRIG MODE Switch | AUTO |
| A TRIG HOLDOFF Control | NORM |

Horizontal Sweep Controls

| | |
|----------------------|-------------------------|
| TIME/DIV Switches | Locked together at 1 ms |
| A TIME/DIV VAR | Calibrated detent |
| HORIZ DISPLAY Switch | A |
| X10 MAG Switch | Off (button out) |
| POSITION Control | Midrange |

Normal Sweep Display

1. Set the POWER switch to on (button out). Allow several minutes for instrument warmup.

2. Connect the external signal to the CH 1 input connector.

3. Advance the INTENSITY control until the display is visible. If the display is not visible with the INTENSITY control at midrange, press the BEAM FIND pushbutton and adjust the CH 1 VOLTS/DIV switch until the display is reduced in size vertically. Then, center the compressed display with the vertical and horizontal POSITION controls, and release the BEAM FIND pushbutton. Adjust the FOCUS control for a well-defined display.

4. Set the CH 1 VOLTS/DIV switch and CH 1 POSITION control for a display which remains in the display area vertically.

5. Adjust the A Trigger LEVEL control for a stable display.

6. Set the A TIME/DIV switch and the horizontal POSITION control for a display which remains in the display area horizontally.

Magnified Sweep Display

1. Preset the instrument controls and follow steps 1 through 6 for obtaining a Normal Sweep Display.

2. Adjust the horizontal POSITION control to move the area to be magnified to within the center graticule division of the CRT. If necessary, change the TIME/DIV switch setting so the complete area to be magnified is within the center division.

3. Set the X10 MAG switch to the on position (button in) and adjust the horizontal POSITION control for precise positioning of the magnified display.

Delayed Sweep Displays

1. Preset the instrument controls and follow steps 1 through 6 for obtaining a Normal Sweep Display.

2. Set the HORIZ DISPLAY switch to A INT and the B Trigger SOURCE switch to STARTS AFTER DELAY.

3. Pull out the B TIME/DIV switch knob and turn clockwise so the intensified zone on the display is the desired length. Adjust the INTENSITY control to achieve the desired display brightness.

4. Adjust the DELAY-TIME POSITION dial to position the intensified zone to the portion of the display to be delayed.

5. Set the HORIZ DISPLAY switch to B DLYD. The intensified zone on the display noted in step 3 is now being displayed in delay form. The delayed sweep rate is indicated by the dot on the B TIME/DIV switch knob.

6. For a delayed sweep display that will exhibit less jitter, set the B Trigger SOURCE switch to the same position as the A Trigger SOURCE switch and adjust the B Trigger LEVEL control for a stable display. If the A Trigger SOURCE switch is in the LINE position, a sample of the line voltage will have to be supplied to the B Trigger circuit externally.

Mixed Sweep Display

1. Preset the instrument controls and follow steps 1 through 6 for obtaining a Normal Sweep Display.

2. Pull out on the B TIME/DIV switch knob and turn clockwise to the desired sweep rate. Adjust the INTENSITY control to achieve the desired display brightness.

3. Set the HORIZ DISPLAY switch to MIX. The CRT display now contains more than one time factor on the horizontal axis. The first portion of the display is at the A Time Base sweep rate and the latter part is at the B Time Base sweep rate. The start of the B Time Base portion of the display can be changed by adjusting the DELAY-TIME POSITION control.

X-Y Display

1. Preset the instrument controls and turn the instrument power on. Allow several minutes for instrument warm-up.

2. Set the TIME/DIV switch to X-Y and the VERT MODE to CH 2. Apply the vertical signal to the CH 2 or Y input connector and the horizontal signal to the CH 1 or X input connector. The CH 2 POSITION control will provide vertical positioning and the Horizontal POSITION control will provide horizontal positioning.

3. Advance the INTENSITY control until the display is visible. If the display is not visible with the INTENSITY control at midrange, press the BEAM FIND pushbutton and adjust the CH 1 and CH 2 VOLTS/DIV switches until the display is reduced in size both vertically and horizontally. Then, center the compressed display with the vertical POSITION controls, and release the BEAM FIND pushbutton. Adjust the FOCUS control for a well-defined display.

CIRCUIT DESCRIPTION

Introduction

This section of the manual contains a description of the circuitry used in the 465 Oscilloscope. The description begins with a discussion of the instrument, using the basic block diagram shown in Fig. 3-1. Then, each circuit is described in detail using detailed block diagrams to show the interconnections between the stages in each major circuit and the relationship of the front panel controls to the individual stages.

A complete block diagram is located in the Diagrams Section at the back of this manual. This block diagram shows the overall relationship between all of the circuits. Complete schematics of each circuit are also given in the Diagrams Section. Refer to these diagrams throughout the following circuit description for electrical values and relationships.

Digital Logic

Digital logic techniques are used to perform many functions within this instrument. The function and operation of the logic circuits are described using logic symbology and terminology. All logic functions are described using the positive logic convention. Positive logic is a system of notation where the more positive of two levels (HI) is called the true or 1 state; the more negative level (LO) is called the false or 0 state. The HI-LO method of notation is used in this logic description. The specific voltages which constitute a HI or LO state vary between individual devices. Typical HI and LO logic levels are shown on the diagrams at the rear of this manual.

It should be noted that not all of the integrated circuit devices in this instrument are digital logic devices. The function of non-digital devices will be described individually using operating waveforms or other techniques to illustrate their function.

BLOCK DIAGRAM

General

The following discussion is provided to aid in understanding the overall concept of the 465 Oscilloscope before

the individual circuits are discussed in detail. A basic block diagram of the 465 Oscilloscope is shown in Fig. 3-1. Only the basic interconnections between the individual blocks are shown on this diagram. Each block represents a major circuit within the instrument. The number on each block refers to the complete circuit diagram which is located at the rear of this manual.

Signals to be displayed on the CRT are applied to the CH 1 OR X and/or CH 2 OR Y connectors. The input signals are then amplified by the Preamp circuits. Each Preamp circuit includes separate vertical deflection factor, input coupling, balance, gain, and variable attenuation controls. A trigger pickoff stage in each Vertical Preamp circuit supplies a sample of the channel signals to the Trigger Generator circuit. A sample of the Channel 1 signal is also supplied to the CH 1 VERT SIGNAL OUT BNC connector on the instrument rear panel. In the X-Y mode of operation the Channel 1 signal is connected to the input of the Horizontal Amplifier circuit to provide the X-Axis deflection. The Channel 2 Vertical Preamp circuit contains an invert feature to invert the Channel 2 signal as displayed on the CRT. The output of both Vertical Preamp circuits is connected to the Vertical Switching circuit. This circuit selects the channel(s) to be displayed. An output signal from this circuit is connected to the Z Axis Amplifier circuit to blank out the switching transients between channels when in the chopped mode of operation. A trigger pickoff stage at the output of the Vertical Switching circuit provides a sample of the displayed signal(s) to the Trigger Generator circuit.

The output of the Vertical Switching circuit is connected to the Vertical Output Amplifier through the Delay Line. The Vertical Output Amplifier circuit provides the final amplification for the signal before it is connected to the vertical deflection plates of the CRT. This circuit includes the BEAM FIND switch which compresses the vertical and horizontal deflection to within the viewing area to aid in locating an off-screen display.

The A and B Trigger Generator circuits produce an output pulse which initiates the sweep signal produced by the A or B Sweep Generator circuits. The input signal to the A and B Trigger Generator circuits can be individually selected from the Channel 1 signal, Channel 2 signal, the signal(s) displayed on the CRT, a signal connected to the external trigger input connectors, or a sample of the line

voltage applied to the instrument. Each trigger circuit contains level, slope, coupling, and source controls.

The A Sweep Generator circuit, when initiated by the A Trigger Generator circuit, produces a linear sawtooth output signal, the slope of which is controlled by the A TIME/DIV switch. The TRIG MODE switch controls the operating mode of the A Sweep Generator circuit. In the AUTO position, the absence of an adequate trigger signal causes the sweep to free run. In the NORM position, a horizontal sweep is presented only when correctly triggered by an adequate trigger signal. Pushing the SING SWP pushbutton allows one (and only one) sweep to be initiated. The Z Axis Logic circuit produces an unblanking gate signal to unblank the CRT so that the display can be presented. This gate signal is coincident with the sawtooth produced by the A Sweep Generator circuit. A gate signal, which is also coincident with the sawtooth, is available at the A + GATE connector on the instrument rear panel. The Z Axis Logic circuit also produces an alternate sync pulse which is connected to the Vertical Switching circuit. This pulse switches the display between channels at the end of each sweep when the VERT MODE switch is in the ALT position.

The B Sweep Generator circuit is basically the same as the A Sweep Generator circuit. However, this circuit only produces a sawtooth output signal after a delay time determined by the A TIME/DIV switch and the DELAY TIME POSITION dial. If the B Triggering SOURCE switch is set to the STARTS AFTER DELAY position, the B Sweep Generator begins to produce the sweep immediately following the selected delay time. If this switch is in one of the remaining positions, the B Sweep Generator circuit does not produce a sweep until it receives a trigger pulse occurring after the selected delay time.

The output of either the A or B Sweep Generator is amplified by the Horizontal Amplifier circuit to produce horizontal deflection for the CRT except in the fully counterclockwise (X-Y) position of the TIME/DIV switch. This circuit contains a 10X magnifier to increase the sweep rate 10 times in any A or B TIME/DIV switch position. Other horizontal deflection signals can be connected to the horizontal amplifier by using the X-Y mode of operation. When the TIME/DIV switch is set to X-Y, the X signal is connected to the Horizontal Amplifier circuit through the Channel 1 Vertical Preamp circuit.

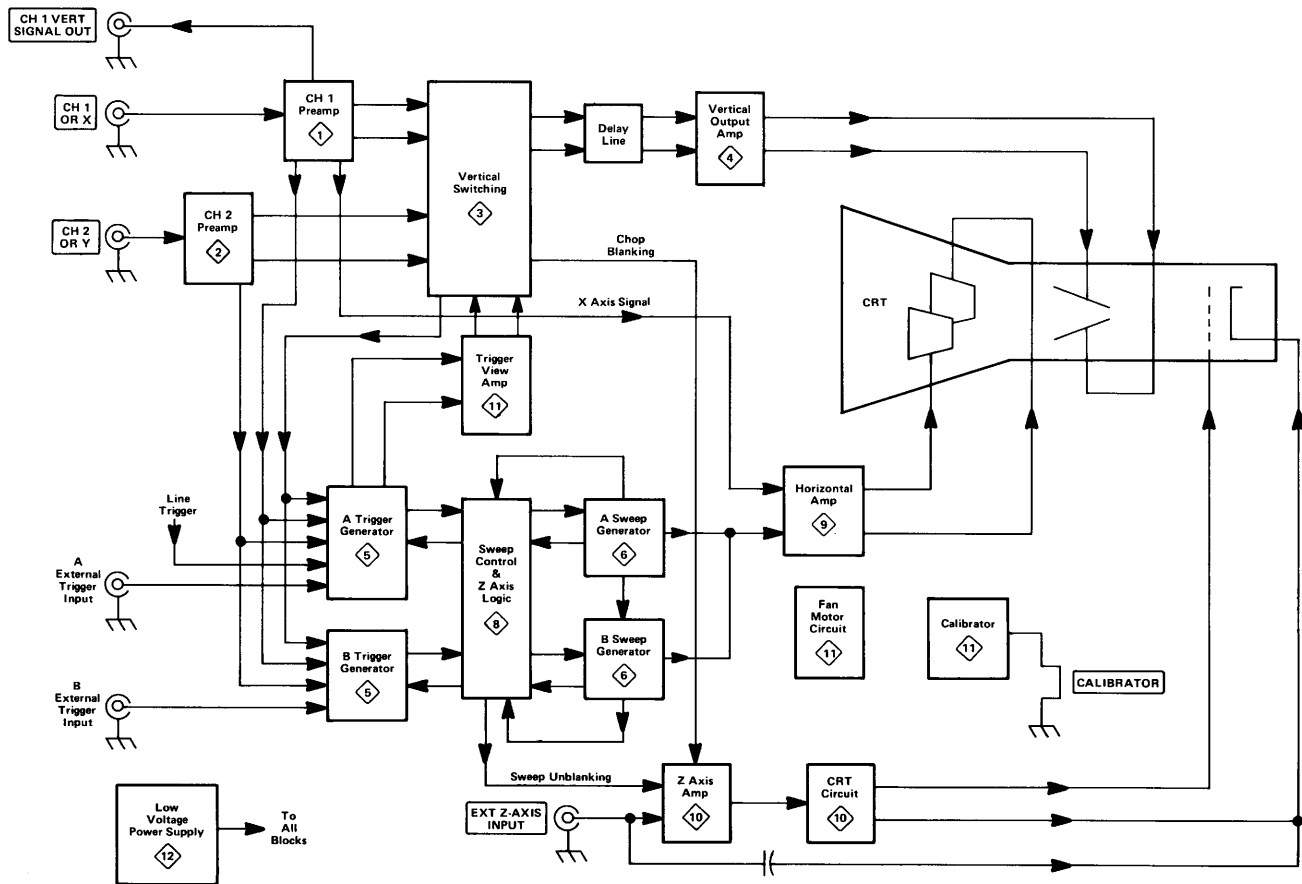

Fig. 3-1. Basic block diagram of the 465.

The Z Axis Amplifier circuit determines the CRT intensity and blanking. The Z Axis Amplifier circuit sums the current inputs from the INTENSITY control, Vertical Switching circuit (chopped blanking), Z Axis Logic circuit (unblanking), and the external Z AXIS INPUT connector. The output level of the Z Axis Amplifier circuit controls the trace intensity through the CRT Circuit. The CRT circuit provides the voltages and contains the controls necessary for operation of the cathode-ray tube.

The Power Supply circuit provides the low voltage power necessary for operation of this instrument. This voltage is distributed to all of the circuits in the instrument as shown by the Power Distribution Diagram. The Calibrator circuit produces a square-wave output with accurate voltage and current amplitudes which can be used to check the calibration of the instrument and the compensation of probes. The CALIBRATOR current loop provides an accurate current source for calibration of current measuring probe systems.

CHANNEL 1 PREAMP

General

Input signals for vertical deflection on the CRT can be connected to the CH 1 OR X input connector. In the X-Y mode of operation the input signal connected to the CH 1 OR X connector provides the horizontal (X axis) deflection (TIME/DIV switch set to X-Y, VERT MODE switch set to CH 2 OR X-Y). The Channel 1 Preamp circuit provides control of input coupling, vertical deflection factor, gain, and DC balance. Fig. 3-2 shows a detailed block diagram of the Channel 1 Preamp circuit. A schematic of this circuit is shown on Diagram 1 at the rear of the manual.

Input Coupling

Signals applied to the input connector can be AC coupled, DC coupled, or internally disconnected from the input to the Vertical Input Amplifier circuits. When the Input Coupling switch S5 is set for DC coupling, the input signal is coupled directly to the Input Attenuator stage. When AC coupled, the input signal passes through capacitor C3. This capacitor prevents the DC component of the signal

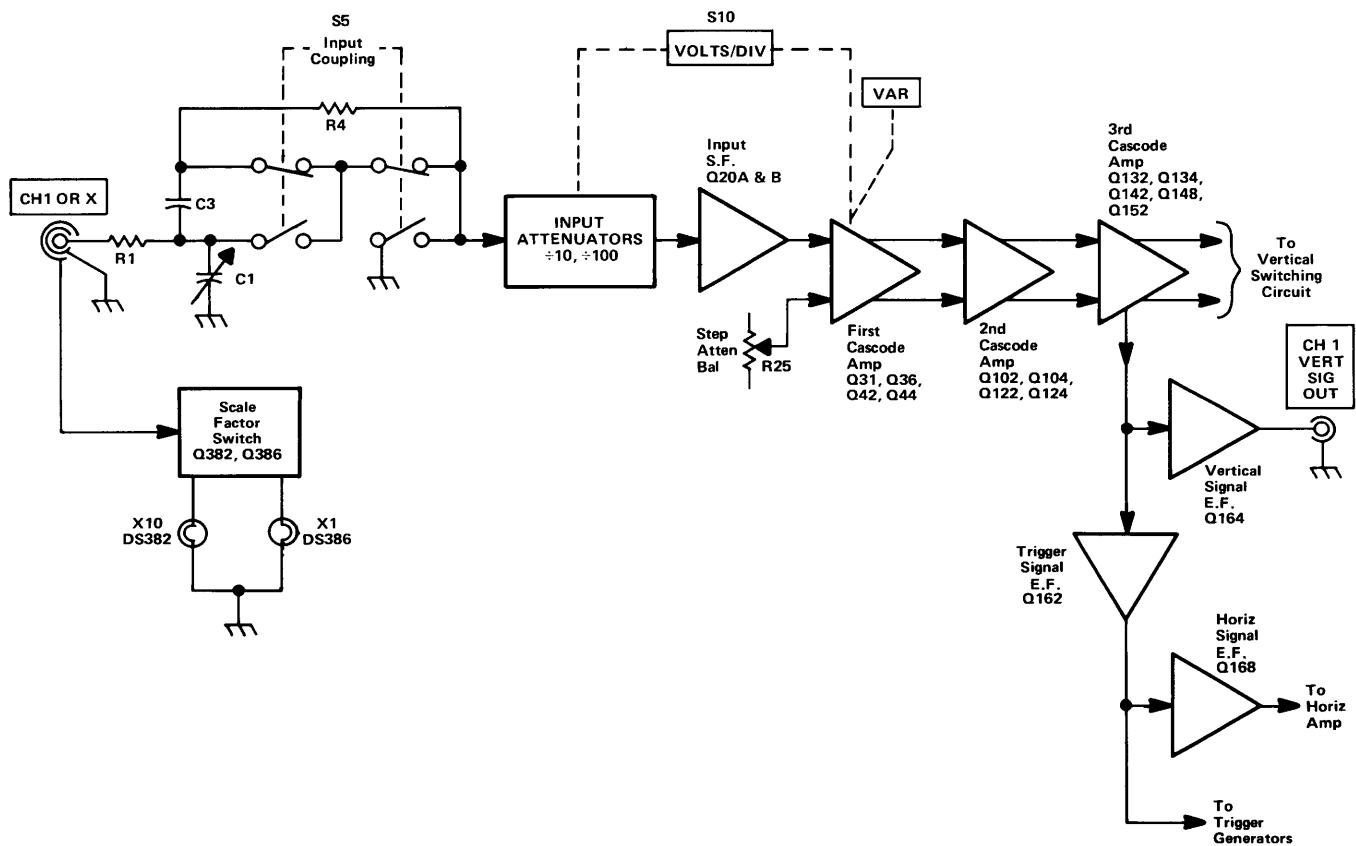

Fig. 3-2. Detailed block diagram of the Channel 1 Preamplifier.

Circuit Description—465

from passing to the amplifier. In the GND position, S5 opens the signal path and connects the input of the amplifier to ground. This provides a ground reference without the need to disconnect the applied signal from the input connector. Resistor R4, connected across the input coupling switch, allows C3 to be pre-charged in the ground position so that the trace remains on screen when switched to the AC position.

Input Attenuator

The effective overall deflection factor of each channel of the 465 is determined by the appropriate VOLT/DIV switch. The basic deflection factor of the Vertical Deflection System is 5 mV/division of CRT deflection. To achieve the deflection factor values indicated on the front panel, precision attenuators are switched in to the circuit and the gain of the First Cascode Amplifier stage is changed.

For the VOLT/DIV switch positions above 5 mV, attenuators are switched in to the circuit, singly or in pairs, to help produce the vertical deflection factors indicated on the front panel. These attenuators are frequency-compensated voltage dividers. In addition to providing constant attenuation at all frequencies within the bandwidth of the instrument, the Input Attenuators are designed to maintain the same input RC characteristics (1 M Ω times approximately 20 pF) for each setting of the VOLT/DIV switch. Each attenuator contains an adjustable series capacitor to provide correct attenuation at high frequencies and an adjustable shunt capacitor to provide correct input capacitance.

NOTE

Each attenuator is a hybrid encapsulated plug-in assembly; therefore, replacement of individual components within the attenuator is not possible. Should defects occur, the attenuator must be replaced as a unit.

Scale-Factor Switching Circuit

The vertical deflection factor for each channel is indicated by back-lighting the appropriate figures imprinted on the flange of the VOLTS/DIV knob. When a X1 probe is connected to the CH 1 OR X input connector, the base level of transistor Q386 is determined by the voltage divider composed of R384, R383 and X10 display factor bulb DS382. Q386 is biased into saturation and conducts current through the X1 indicator DS386. When Q386 conducts, the voltage level at its collector is very close to +5 volts. Therefore, there is insufficient bias at the base of Q382 to cause Q382 to conduct, and the X1 indicator DS382 remains dark.

When a X10 probe with a scale factor switching connector is attached to the CH 1 OR X input connector, the base of Q382 is returned to ground through R381. Q382 is now biased into saturation and conducts current through X10 indicator DS382. The collector level of Q382 is very close to +5 volts; therefore, there is insufficient bias at the base of Q386 to cause it to conduct and X1 indicator DS386 remains dark.

Source Follower Stage

The Channel 1 signal from the Input Attenuator is connected to the Source Follower Stage through R16 and C16. R15 provides the input resistance for this stage. R16 limits the current drive to the gate of Q20A. Diode CR18 protects the circuit by clamping the gate of Q20A at about -8.7 volts if a high amplitude negative-going signal is applied to the CH 1 OR X input connector. Q20B is a relatively constant current source for Q20A.

First Cascode Amplifier Stage

The Paraphase Amplifier Stage composed of Q32 and Q36 converts the single-ended input signal into a push-pull output signal. C33, C34 and CR34 optimize high frequency response through the amplifier stage. R37 and R38 provide thermal balance for the amplifier. C37 and C38 minimize Miller effect through Q32 and Q36. Step Atten Bal adjustment R25 adjusts for no baseline shift of a CRT display when switching between adjacent positions of the VOLTS/DIV switch.

The Common Base Amplifier stage composed of Q42 & Q44 converts the input signal currents into output voltage signals across load resistors R44 and R45. Correct vertical deflection factors are obtained by using a combination of attenuation in the Input Attenuator Stage and changing the gain of the first Cascode Amplifier Stage. For example, when switching from 50 mV/division to 100 mV/division, the input attenuator remains the same but R46 is switched in parallel with R44 and R45. This divides the output load resistance of the Common Base Amplifier Stage by two, thereby reducing the gain of the stage by two. C46, C47, C48, C49, R47 and R48 provide optimum high frequency response through the channel amplifier when operating with reduced gain.

Second Cascode Amplifier

Transistors Q102-Q122 and Q104-Q124 constitute the Second Cascode Amplifier stage of the Channel 1 vertical preamplifier. Gain adjust R118 sets the overall gain of the Channel 1 vertical preamplifier by adjusting the signal current into the emitters of Q122 and Q124. The VAR control R112, when rotated out of the calibrated detent

position, also adjusts the signal currents into Q122 and Q124 to provide uncalibrated deflection factors between the calibrated settings of the VOLTS/DIV switch. Variable balance adjustment R120 adjusts for no baseline shift of a CRT display when rotating the VAR control. Position Centering adjustment R115 centers the range of control of the Channel 1 POSITION control.

Third Cascode Amplifier

Q132 and Q134, in conjunction with Q304 and Q308 in the Vertical Switching Circuit, form the Third Cascode Amplifier stage. Thermistor RT131 (between the emitters of Q132 and Q134) changes in value with changes in temperature. This varies the gain of the Third Cascode Amplifier stage to compensate for changes in total amplifier gain that occur with variations in operating temperature. The push-pull signals picked off in the emitters of Q132 and Q134 are converted to a single-ended signal by Q142 and Q148. This signal is amplified by common-base amplifier stage Q152 and applied to the bases of emitter followers Q162 and Q164. Q164 provides the output signal to the CH 1 VERT SIGNAL OUT connector located on the instrument rear panel. The output signal at the emitter of Q162 is used as the trigger signal source in the CH 1 positions of the Trigger SOURCE switches and as the signal source for emitter follower Q168. Q168 provides the X-axis signal from the Channel 1 Preamp to the Horizontal Amplifier in the X-Y mode of operation. CR164, CR165, CR166, and CR167 protect the emitter circuit of Q164 in the event large voltage levels are accidentally connected to the CH 1 VERT SIGNAL OUT connector. R155 adjusts the DC level of the CH 1 trigger source signal.

CHANNEL 2 PREAMP

General

The Channel 2 Preamp circuit is basically the same as the Channel 1 Preamp. Only the specific differences between the two circuits are described here. Portions of this circuit not described in the following description operate in the same manner as for the Channel 1 Preamp. Fig. 3-3 shows a detailed block diagram of the Channel 2 Preamp circuit. A schematic of this circuit is shown on diagram 2 at the rear of this manual.

Second Cascode Amplifier

The Second Cascode Amplifier in Channel 2 is basically the same as the Second Cascode Amplifier in Channel 1 except that the Channel 2 INVERT switching takes place here. For a normal (non-inverted) display, +5 volts is connected to the bases of transistors Q222 and Q224 by INVERT switch S225. The voltage divider comprised of R225 and R226 applies approximately +2.5 volts to the base of Q226 and Q228. Q222 and Q224 are biased on and Q226 and Q228 are biased off, and the signal passes on to the output cascode amplifier stage normally. With the INVERT switch in the INVERT (button in) position, +5 volts is applied to the bases of Q226 and Q228. The voltage divider composed of R225 and R224 applies approximately +2.5 volts to the bases of Q222 and Q224. Q226 and Q228 are now biased on and Q222 and Q224 are biased off. The signal that was normally applied to the base of Q232 is now applied to the base of Q234 through transistor Q228 and the signal that was normally applied to the base of Q234 is now applied to the base of Q232 through transistor Q226.

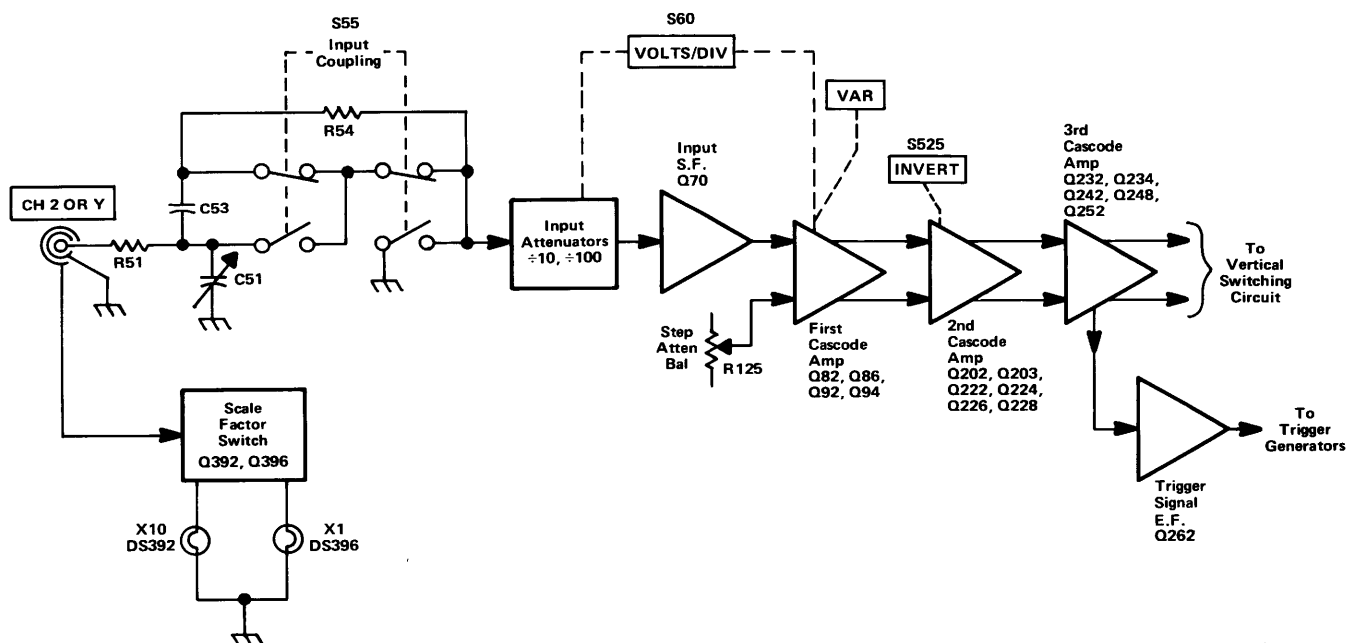

Fig. 3-3. Detailed block diagram of the Channel 2 Preamp.

Third Cascode Amplifier

The trigger pickoff circuit only provides a signal to one emitter follower. This emitter follower (Q262) in turn provides the trigger signal to the Trigger Generator circuits in the CH 2 positions of the SOURCE switches.

Preamp output signals to be coupled to the Vertical Output Amplifier. CR304, CR305, CR307 and CR308 control the Channel 1 output and CR314, CR315, CR317 and CR318 control the Channel 2 output. These diodes are in turn controlled by the Switching Multivibrator for dual trace displays, or by the VERT MODE switch for single trace displays.

VERTICAL SWITCHING CIRCUIT

General

The Vertical Switching Circuit determines whether the Channel 1 or Channel 2 or both signals are connected to the Vertical Output Amplifier Circuit. In the alternate and chopped modes of operation both channels are alternately displayed on a shared time basis. Fig. 3-4 shows a detailed block diagram of the Vertical Switching Circuit. A schematic of this circuit is shown on diagram 3 at the rear of this manual.

Diode Gates

The Diode Gates, consisting of four diodes each, can be thought of as switches which allow either of the Vertical

Channel 1 Only Display. When the CH 1 pushbutton is pressed, -8 volts is applied to the junction of CR315-CR317 in the Channel 2 Diode Gate through R367 (see simplified diagram in Fig. 3-5). This forward biases CR315 and CR317 and reverse biases CR314 and CR318. CR314 and CR318 block the Channel 2 signal so it cannot pass to the Delay Line Driver stage. At the same time in the Channel 1 Diode Gate, CR305 and CR307 are connected to +5 volts through R371. CR305 and CR307 are held reverse-biased while CR304 and CR308 are forward biased. Therefore, the Channel 1 signal passes to the Delay Line Driver stage.

Channel 2 Display Only. When the CH 2 pushbutton is pressed, the above conditions are reversed. The junction of CR305-CR307 is connected to -8 volts through R376 and

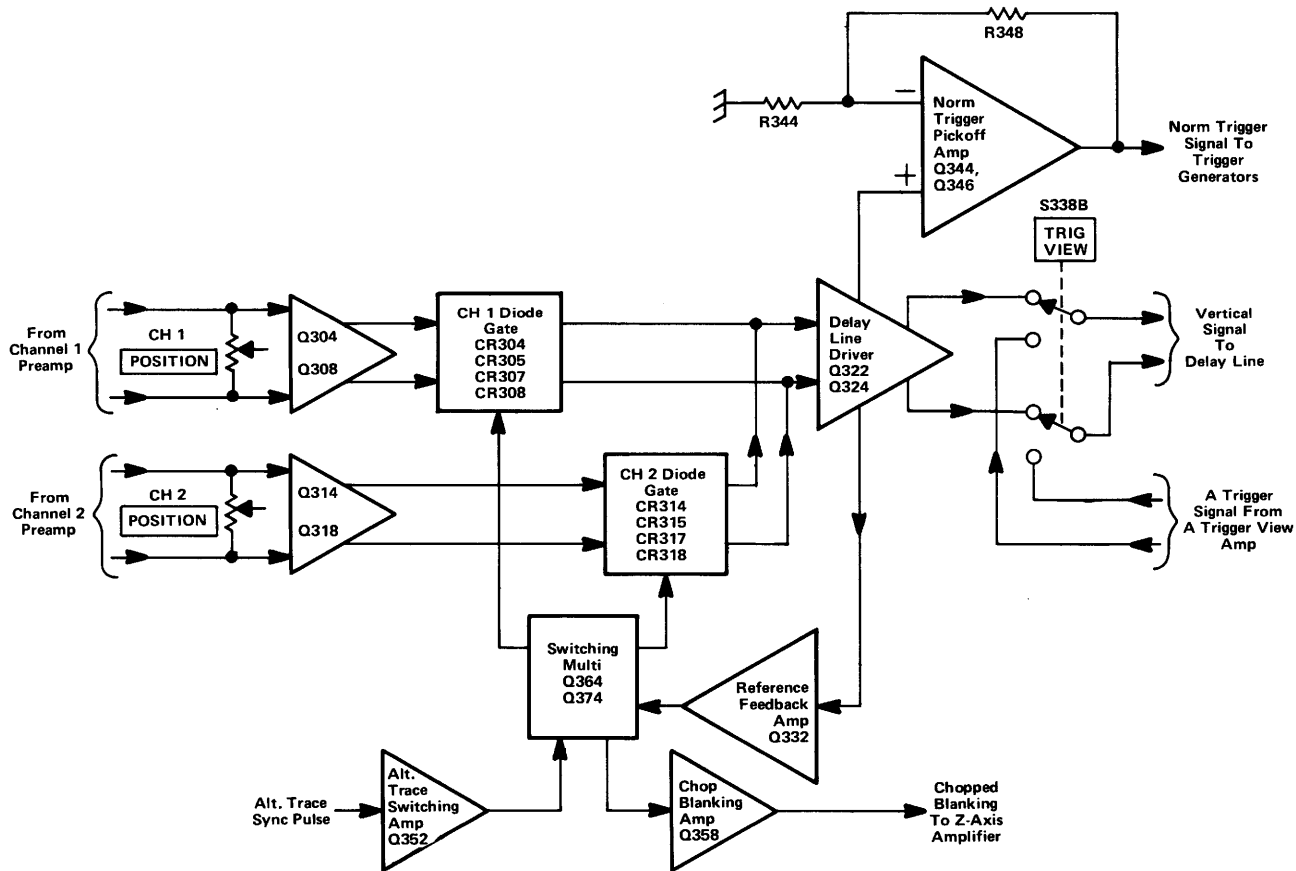

Fig. 3-4. Detailed block diagram of the Vertical Switching Circuit.

the junction of CR315-CR317 is connected to +5 volts through R361. The Channel 1 Diode Gate blocks the Channel 1 signal and the Channel 2 Diode Gate allows the Channel 2 signal to pass to the Delay Line Driver stage.

Switching Multivibrator

Alternate Trace Display. In this mode of operation, the Switching Multivibrator operates as a bistable multivibrator. When the ALT pushbutton is pressed, -8 volts is applied to the emitter of Alternate Trace Switching Amplifier stage Q352 by the VERT MODE switch. Q352 is forward biased to supply current to the "on" Switching-Multivibrator transistor through R352 and CR368 or CR378. For example, if Q374 is conducting, current is supplied to Q374 through R352 and CR378. The current flow through collector resistor R371 drops the CR305-CR307 cathode level negative so that the Channel 1 Diode Gate is blocked as for Channel 2 Only Operation. The signal passes through the Channel 2 Diode Gate to the Delay-Line Driver stage.

The alternate trace sync pulse is applied to the base of Q352 through C351 at the end of each sweep. This

negative-going sync pulse momentarily interrupts the current through Q352 and both Q364 and Q374 are turned off. When Q352 turns on again after the alternate trace sync pulse, the charge on C368 determines whether Q364 or Q374 conducts. For example, when Q374 was conducting, C368 was charged positive on the CR378 side to the emitter level of Q374 and negatively on the CR368 side toward the negative level at the junction of CR368 and CR378. This charge is stored while Q352 is off and holds the emitter of Q364 more negative than the emitter of Q374. During the time Q364 and Q374 are turned off, the voltages at their bases become approximately equal. Now, when Q352 comes back on, the transistor with the most negative emitter conducts first, the resulting negative movement at its collector holds the other transistor off. The conditions described previously are now reversed: now, the Channel 2 Diode Gate is reverse-biased and the Channel 1 signal passes through the Channel 1 Diode Gate.

Chopped Mode Operation. When the CHOP pushbutton is pressed, the Switching Multivibrator stage free-runs at about a 250 kHz rate. The emitters of Q364 and Q374 are connected to -8 volts through R368, R378, and the primary of transformer T354. At the time of turn-on, one

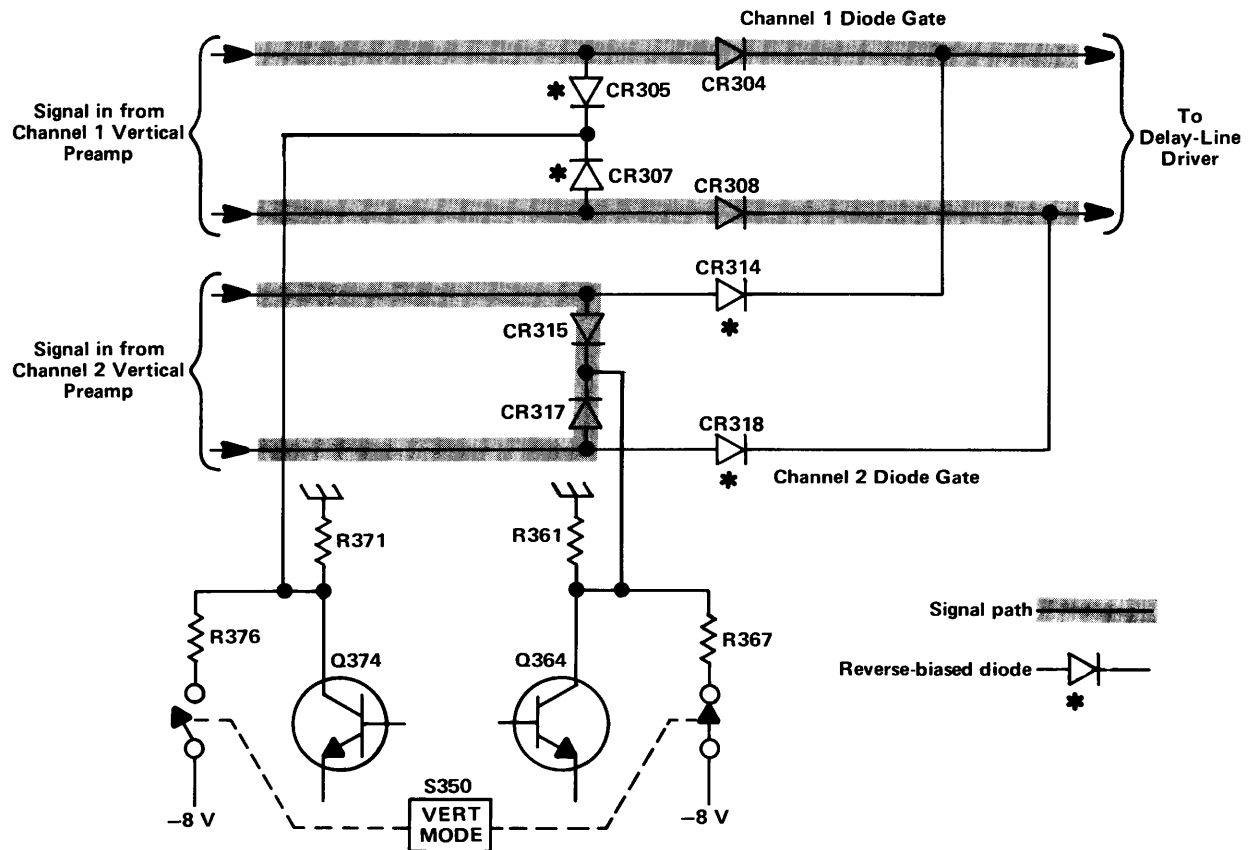

Fig. 3-5. Effect of Diode Gates on signal path (simplified Vertical Switching diagram). Conditions shown for CH 1 position of VERT MODE switch.

of the transistors begins to conduct; for example, Q374. The negative level at the collector of Q374 forward-biases CR305 and CR307 and back-biases CR304 and CR308 preventing the Channel 1 signal from reaching the Delay-Line Driver stage. Meanwhile, the Channel 2 Diode Gate passes the Channel 2 signal to the Delay-Line Driver stage.

The frequency-determining components in the CHOP mode are C368, R368, R370, and R378. The switching action occurs as follows: when Q374 is on, C368 attempts to charge to -8 volts through R368. The emitter of Q364 slowly goes toward -8 volts as C368 charges. The base of Q364 is held at a point determined by the voltage divider R365 and R374 between -8 volts and the collector level of Q374. When the emitter voltage of Q364 reaches a level slightly more negative than its base, Q364 conducts. Its collector level goes negative and pulls the base of Q374 negative through divider R364-R375 to cut Q374 off. This switches the Diode Gate stages to connect the opposite channel to the Delay-Line Driver stage. Again, C368 begins to charge towards -8 volts but this time through R378. The emitter of Q374 slowly goes negative as C368 charges until Q374 turns on. Q364 is shut off and the cycle begins again.

The Chop Blanking Amplifier stage, Q358, provides an output pulse to the Z Axis Amplifier circuit which blanks out the transition between the Channel 1 and the Channel 2 traces. When the Switching Multivibrator stage changes states, the voltage across T354 momentarily increases. A negative pulse is applied to the base of Q358 to turn it off. The width of the pulse at the base of Q358 is determined by R356 and C356. Q358 is quickly driven in to cutoff and the positive going output pulse, which is coincident with trace switching, is connected to the Z Axis Amplifier circuit through R359.

Added Mode Operation. When the ADD pushbutton is pressed, the following occurs:

1. +5 volts is applied to the cathodes of CR305 and CR307 through R371.
2. +5 volts is applied to the cathodes of CR315 and CR317 through R361.
3. -8 volts is applied to the junction of R321 and R322.

The first two actions enable both of the Channel Diode Gates so that the signal applied to the Delay Line Driver stage is the algebraic sum of the Channel 1 and Channel 2 signals. The -8 volts applied to R321 and R322 provides sufficient current to keep both diode gates turned on without altering the DC levels associated with the Delay Line Driver stage.

Delay-Line Driver

The outputs from the Diode Gate stages are applied to the Delay-Line Driver stage composed of Q322 and Q324.

Q322 and Q324 are connected as feedback amplifiers with R325 and R327 providing feedback from the collector to the base of their respective transistors. A sample of the signal in the collector circuit of Q322 is used for triggering in the NORM mode of trigger operation. The BW LIMIT switch S338A connects a pi filter composed of C338, C339, L338, and L339 between the output signal lines of the Delay-Line Driver stage to reduce the upper -3 dB bandwidth limit of the Vertical Amplifier system to approximately 20 MHz. R335 and R336 provide reverse termination for the delay line. The TRIG VIEW switch S338B connects the output of the Trigger View Amplifier to the input of the Delay Line in place of the Delay Driver Stage. This allows viewing the trigger signal present in the A Trigger Generator Circuit.

Reference Feedback Amplifier

Reference Feedback stage Q332 provides common mode voltage feedback from the Delay-Line Driver stage to allow the diode gates to be switched with a minimum amplitude switching signal. The emitter level of Q332 is connected to the junction of the Switching Multivibrator collector resistors, R371 and R361 through CR372 or CR362. The collector level of the "on" Switching Multivibrator transistor is negative and either CR362 or CR372 is forward biased. This clamps the cathode level of the forward biased shunt diodes in the applicable Diode Gate about 0.5 volt more negative than the emitter level of Q332. The level at the emitter of Q332 follows the average voltage level at the emitters of the Delay-Line Driver stage. The shunt diodes are clamped near their switching level and therefore, can be switched very fast with a minimum amplitude switching signal. This maintains about the same current through the Diode Gate shunt diodes so they can be switched with a minimum amplitude switching signal regardless of the deflection signal at the anodes of the shunt diodes.

Normal Trigger Pickoff Amplifier

The trigger signal for NORM trigger operation is obtained from the collector of Q322. Normal Trigger DC Adjustment R340 sets the DC level of the normal trigger output signal so the sweep is triggered at the 0 level of the displayed signal when the Triggering LEVEL control is set to 0. Q344 and Q346 are connected as a feedback amplifier with the signal applied to the non-inverting input and the feedback connected between the output and the inverting input. Gain of the stage is approximately:

$$\frac{R348 + R344}{R344}$$

VERTICAL OUTPUT AMPLIFIER

General

The Vertical Output Amplifier circuit provides the final amplification for the vertical deflection signal. This circuit includes the Delay Line and the BEAM FIND pushbutton. The BEAM FIND pushbutton compresses an overscan

display to within the viewing area when pressed. A schematic of the Vertical Output Amplifier circuit is shown on diagram 4 at the rear of this manual.

Delay Line

Delay Line DL400 provides approximately 120 ns delay for the vertical signal to allow the Sweep Generator circuits time to initiate a sweep before the vertical signal reaches the vertical deflection plates of the CRT. This allows the instrument to display the leading edge of the signal originating the trigger pulse when using internal triggering.

Output Amplifier

U440 is an integrated circuit amplifier stage that provides the final amplification for the vertical signal. R401 and R411 provide forward termination for the delay line. The components connected between pins 2 and 4 of U440 provide delay-line compensation. Components connected between pins 14 and 15 and pins 7 and 8 of U440 provide thermal compensation for the stage. The BEAM FIND switch, when pressed, reduces the dynamic swing capabilities of the stage, thereby limiting the display to within the display area of the CRT.

A AND B TRIGGER GENERATORS

General

The Trigger Generator circuits produce trigger pulses to start the Sweep Generator circuits. These trigger pulses are derived either from the internal trigger signal from the vertical deflection system, an external signal connected to the external trigger input connectors, or a sample of the line voltage applied to the instrument. Controls are provided in each circuit to select trigger level, slope, coupling, and source. Since the A and B Trigger Generator circuits are virtually the same, only the A Trigger Generator circuit action and the differences between the A and B Trigger Generator circuits are explained. A schematic of these circuits is shown on diagram 5 at the back of this manual.

Trigger Source

The Trigger SOURCE switch S610 selects the source of the trigger signal. The sources available to the A Trigger Generator circuit are the signal(s) being displayed (NORM), Channel 1 (CH 1), Channel 2 (CH 2), LINE, and EXT. The EXT $\div 10$ (A trigger circuit only) position provides 10 times attenuation for the external trigger signal. The B Trigger SOURCE switch does not have a LINE or an EXT $\div 10$ position, but has a STARTS AFTER DELAY position.

In the LINE mode of triggering, a sample of the power line frequency is obtained from the secondary of power transformer T1501 in the Low Voltage Power Supply circuit. To prevent unwanted attenuation of the trigger signal by the LF REJ circuit, the Trigger COUPLING switches should not be in the LF REJ mode when using line voltage as a trigger source.

Trigger Coupling

The Trigger COUPLING switches offer a means of accepting or rejecting certain components of the trigger signal. In the AC, LF REJ, and HF REJ mode of trigger coupling, the DC component of the trigger signal is blocked by coupling capacitors C612 or C611. Frequency components below about 60 Hz are attenuated when using AC or HF REJ coupling and below about 15 kHz when using LF REJ coupling. The higher frequency components of the trigger signal are passed without attenuation. In the HF REJ mode of trigger coupling, the high frequency components of the trigger signal (above about 50 kHz) are attenuated, while the lower frequency components are passed without attenuation. The DC mode of trigger coupling passes unattenuated all signals from DC to 100 MHz and above.

Input Source Follower

Transistor Q622 is an FET source follower. It provides a high input impedance (set primarily by R616) for the trigger signal and also provides isolation between the Trigger Generator circuit and the trigger signal source. Diode CR617 provides input protection for Q622 if excessively high amplitude negative-going input signals are present. Q624 is a high-impedance, relatively constant, current source for Q622, and provides a measure of temperature compensation for Q622.

Paraphase Amplifier

U640 is a paraphase amplifier stage that converts the single-ended input from Source Follower Q622 into a push-pull output applied to the tunnel diode driver stage. Trigger Level Centering adjustment R635 sets the level at pins 14 and 15 of U640 so that the display is correctly triggered when the LEVEL control is centered. The LEVEL control varies the level at pins 14 and 15 of U640 to select the point on a trigger signal where triggering occurs.

The slope of the input signal that triggers the Sweep Generator circuit is determined by the setting of the SLOPE switch S630. When the SLOPE switch is set to the + position, the output signal present at pin 8 of U640 is in phase with the input signal and the output signal at pin 9 is

Circuit Description—465

inverted with respect to the input signal. When the SLOPE switch is set to the — position, the output signal at pin 8 is inverted with respect to the input signal and the output signal at pin 9 is in phase with the input signal.

Tunnel Diode Driver

Q650 and Q652 are common-emitter amplifier stages that provide the signal currents necessary to switch the triggering tunnel diodes. CR650 and CR652 are 4.7 mA tunnel diodes. Quiescently (i.e., after the sweep holdoff period has passed, but before triggering), CR650 and CR652 are biased into their low voltage states. Q650 cannot provide sufficient current to switch CR650 to its high voltage state. Q652, however, can provide sufficient current to bias CR652 into its high voltage state; when Q652 next conducts triggering signal current, the anode of CR652 steps positive to an approximate +0.5 volt level. Since only approximately 1 mA of current is required to maintain CR652 in its high voltage state, this makes approximately 3 mA of current additionally available with which to switch CR650 to its high voltage state. Thus, the next time Q650 conducts signal current, CR650 steps to its high voltage state, sending a positive pulse to the logic circuit to initiate sweep action. A Trigger Sensitivity adjustment R655 adjusts the tunnel diode bias to the proper level that will not allow CR650 to be switched to its high voltage state until CR652 has been switched to its high voltage state. At the end of the sweep time and during holdoff, a negative level is applied to the anode of CR652,

thereby resetting both CR650 and CR652 to their low voltage states. The reset level remains during holdoff time to ensure that a sweep gating signal will not be generated until the sweep circuit has returned to its quiescent state.

A AND B SWEEP GENERATORS

General

The A and B Sweep Generators produce sawtooth voltages which are amplified by the Horizontal Amplifier circuit to provide horizontal deflection on the CRT. These sawtooth voltages are produced on command (trigger pulses) from the Trigger Generator circuits. The Sweep Generator circuits also produce gate waveforms that are used by the Z Axis Logic circuit to unblank the CRT during sweep time, and by the Sweep Logic circuit to terminate sweep generation. Fig. 3-6 shows a detailed block diagram of the A Sweep Generator circuit. The B Sweep Generator circuit is very similar to the A Sweep Generator; therefore only the differences in operation associated with the B Sweep Generator will be discussed. A schematic of both circuits is shown on diagram 6 at the rear of this manual.

Disconnect Amplifier

After holdoff but before the next sweep, Disconnect Amplifier Q1024 conducts current through R1024 and the timing resistor R_t . This prevents timing current from

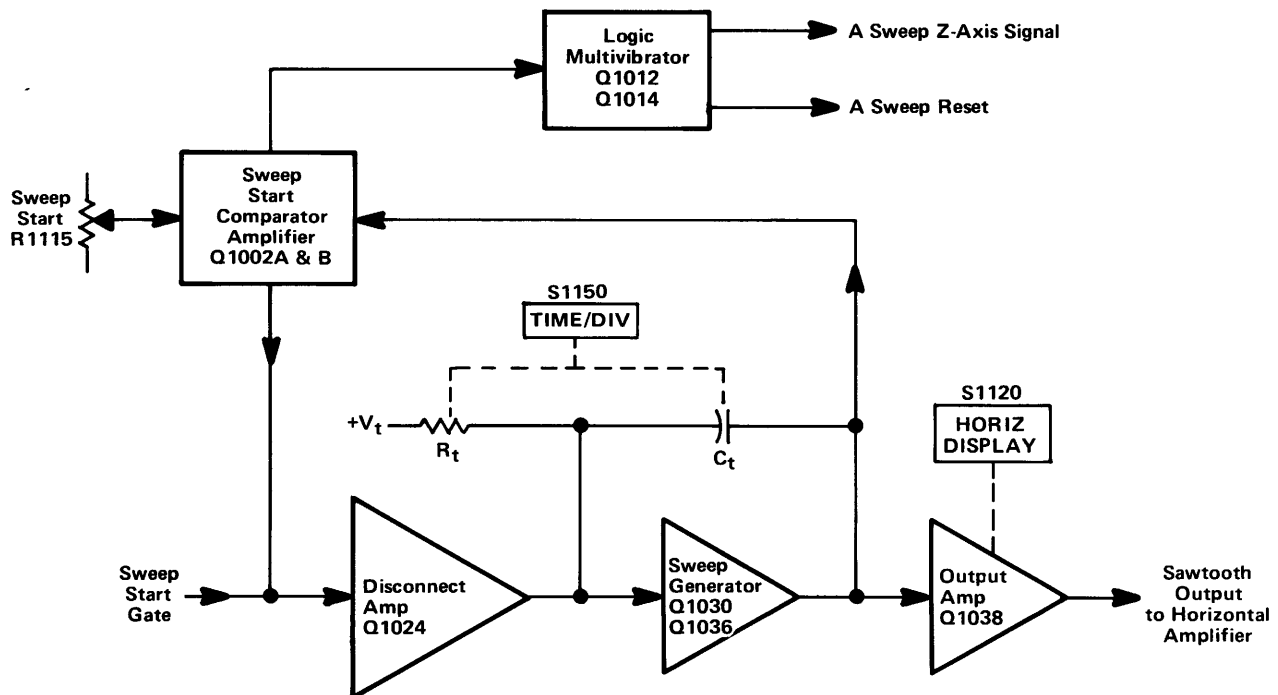

Fig. 3-6. Detailed block diagram of the A Sweep Generator.

charging the timing capacitance C_t . The positive-going sweep start gate from Q864 turns off Q1024 and the timing current now begins to charge the timing capacitance.

Sawtooth Sweep Generator

Q1030 and Q1036 compose a Miller Integrator circuit. When the current flow through the Disconnect Amplifier is interrupted, the timing capacitance begins to charge through the timing resistor. The timing resistor and capacitance are selected by the A TIME/DIV switch to provide the various sweep rates listed on the instrument front panel. The output signal at the collector of Q1036 is a negative-going sawtooth waveform.

Output Buffer Amplifier

The Output Buffer Amplifier stage is a common-base amplifier with the signal current-driven into the emitter. It provides the output sawtooth current signal to the Horizontal Amplifier and provides a measure of isolation between the Sawtooth Generator and the Horizontal Amplifier. The HORIZ DISPLAY switch connects to this stage to control the A sawtooth output in the various horizontal modes of operation. In the A and A INTEN modes of operation, the A sweep signal passes through Q1038 to the Horizontal Amplifier. However, in the MIX and B DLY'D modes, -8 volts is connected to zener diode VR1039 which sets the emitter of Q1038 at about -1.8 volts. This biases Q1038 off, preventing the A sawtooth signal from passing to the Horizontal Amplifier.

Sweep Start Amplifier

Just before the sweep starts to run down, the levels at the bases of Q1002 A and B are approximately equal. When the sweep starts to run down, the base of Q1002B goes negative, which increases the forward bias on CR1004. This in turn decreases the forward bias on CR1001, which, very shortly after the start of the sweep, becomes reverse biased to interrupt the current through Q1002A. The circuit remains in this condition until after the sweep retrace is complete. When the circuit returns to quiescence, Q1002A again begins to conduct through R1024. This sets the current through Q1024, which establishes the starting point for the sweep. The Sweep Start adjustment sets the base level of Q1002A. This level is also connected to the base of Q1062A in the B Sweep Generator except in the MIX mode of operation. This ensures that B Sweep starts at the same level as A Sweep.

Logic Multivibrator

Q1012 and Q1014 compose a multivibrator. At quiescence, Q1014 is conducting and Q1012 is turned off. When

the sweep starts to run, the negative-going ramp is coupled through the base of Q1002B and CR1004 to the cathode of CR1011. CR1011 becomes forward biased and when the level at the anode of CR1011 falls to about $+4$ volts Q1012 conducts and Q1014 turns off. The multivibrator remains in this state until the sweep starts to retrace and the voltage level at the anode of CR1011 rises above about $+4.5$ volts. The resultant pulse at the collector of Q1012 is applied to Sweep Control IC U870 to terminate the sweep. The pulse at the collector of Q1014 is applied to the A Sweep Z Axis Logic Gate to blank the CRT at the end of the sweep.

B Sweep Generator Differences

There are three prime differences between the A and B Sweep Generators. The B Sweep Output Buffer Amplifier is prevented from passing the B Sweep signal to the Horizontal Amplifier in the A and A INTEN positions of the HORIZ DISPLAY switch. There is a transistor stage connected as a constant current source in the emitter circuit of Q1062A and B (corrects for current imbalances side-to-side in Q1062 during MIX mode operation). The Sweep Start Level connected to the base of Q1062A is not always a fixed DC level. During MIX mode operation the A Sweep Sawtooth signal is applied to the base of the amplifier. Now, the DC level at which the B Sweep Generator will start generating its sawtooth waveform is constantly being changed by the A Sweep sawtooth. The output waveform from the B Sweep Generator takes the form of a composite sawtooth waveform, with the first and last parts occurring at a rate determined by the A Sweep Generator and the middle part occurring at a rate determined by the B Sweep Generator.

SWEEP AND Z AXIS LOGIC CIRCUIT

General

The Sweep And Z Axis Logic Circuit derives the logic levels necessary to control the sequence of events associated with sweep generation and CRT unblanking. The +A and +B GATE signals are also generated in this circuit. Positive logic terminologies and symbologies will be used in the following explanation of circuit operation. A schematic of this circuit is shown on diagram 8 at the rear of this manual.

A Sweep Gate

Q862 and Q864 compose the A Sweep Gate Circuit. They form an emitter coupled stage where only one transistor can be conducting at any time. The input signal to the stage is the positive-going trigger signal from the A Fire Trigger TD in the A Trigger Generator Circuit. The

Circuit Description—465

signal at the collector of Q862 is connected to the A Z Axis Gate Circuit to control CRT blanking and to generate the + A GATE signal. The signal at the collector of Q864 is connected to the emitter of the Sweep Disconnect Amplifier stage (Q1024) in the A Sweep Generator Circuit to initiate A Sweep generation.

B Sweep Gate

Q812 and Q814 compose the B Sweep Gate Circuit. They also form an emitter-coupled stage where only one transistor can be conducting at any time. The input signal to the stage is the positive-going trigger signal from the B Fire Trigger TD in the B Trigger Generator Circuit. The signal at the collector of Q812 is connected to the B Z Axis Gate Circuit to control CRT blanking and to generate the + B GATE signal. The signal at the collector of Q814 is connected to the emitter of the Sweep Disconnect Amplifier stage (Q1084) in the B Sweep Generator Circuit to initiate B Sweep generation.

Sweep Control Integrated Circuit

U870 is the Sweep Control Integrated Circuit. Several functions are performed in this stage, depending on the mode of operation of the instrument sweep generators. The following is a brief explanation of the function associated with each pin of the IC.

Pin 1. This is the positive Auto Sense input. The signal connected here comes from the A Fire Trigger TD.

Pin 2. This is the negative Auto Sense input. A fixed DC level established by R871 and R872 is connected here.

Pin 3. This is the + auto gate terminal. In the AUTO mode of operation, if no trigger signals are applied to pin 1 of U870 during the ≈ 100 ms following the end of holdoff the gate level at pin 3 steps LO to turn Q864 on which initiates a sweep.

Pin 4. Not used in this application.

Pin 5. Input terminal for negative voltage supply.

Pin 6. This is the auto gate timing terminal. R879 and C879 determine the amount of time between the end of holdoff and the generation of the auto gate.

Pin 7. This terminal lights the TRIG'D light when a triggered gate has occurred.

Pin 8. This is the holdoff timing terminal. The R/C connected to this terminal (selected by the TIME/DIV switch) determines the length of holdoff time.

Pin 9. Ground terminal.

Pin 10. This is the Holdoff output terminal. The gate level present here is LO during sweep holdoff time and HI otherwise.

Pin 11. This terminal lights the READY light when operating in the single sweep mode.

Pin 12. This is the single sweep mode terminal. When +5 volts is applied to this terminal the sweep operates in the single sweep mode; when the terminal is left open or grounded the sweep operates in the repetitive mode.

Pin 13. Not used in this application.

Pins 14 & 15. Single sweep reset terminals. Pushing the PUSH TO RESET button prepares the single sweep circuitry to respond to the next one triggering event. Also causes the READY light to be lit.

Pin 16. This is the holdoff start input terminal. The HI sweep reset gate pulse from the sweep generators is applied here to initiate sweep holdoff.

Pin 17. This is the sweep disable output terminal. The gate level at this terminal is HI during holdoff and LO otherwise.

Pin 18. Sweep lockout input. +5 volts applied to this terminal disables all sweep action.

Pin 19. Auto mode terminal. Grounding this terminal enables auto sweep operation.

Pin 20. Input terminal for positive voltage supply.

A Sweep Holdoff Amplifier

Q854 is the A Sweep Holdoff Amplifier. The holdoff gate waveform is applied to the base of Q854 through R858 and C858 from pin 17 of U870. When Q854 is turned off (during holdoff time), its collector is LO and CR851 is forward biased, which resets both the Arm and Fire trigger TD's in the A Trigger Generator. When Q854 is turned on (any time other than holdoff time), its collector level is HI and CR851 is reversed biased. This allows the trigger TD's in the A Trigger Generator to respond to the next adequate triggering signal.

B Sweep Holdoff Amplifier

Q804 is the B Sweep Holdoff Amplifier. Its circuit action is identical to that described for the A Sweep Holdoff Amplifier except that there are three gate signal sources that control the state of the stage. The three sources are the holdoff gate from pin 17 of U870 (through CR859), the collector of Q1052 in the Delay Pickoff Comparator, and the collector of Q822 in the B Latch Multivibrator (through CR809). All three gate sources must be in their LO state for B Sweep to be triggerable; any one of the sources in its HI state will disable the B Trigger Generator TD's.

A Sweep Z-Axis Gate

Q1304 and Q1306 comprise the A Sweep Z-Axis Gate. They form an emitter-coupled stage where only one transistor can be conducting at any time. The controlling signal inputs come from the collector of Q862 in the A Sweep Gate, the blanking signal from Q1014 in the A Sweep Generator, and Q824 in the B Latch Multivibrator (only in the MIX mode of operation). The blanking signal for use in the Z-Axis Amplifier is taken from the collector of Q1306 (through CR1342). The collector signal of Q1304 is applied to the +A GATE Emitter Follower.

In all positions of the HORIZ DISPLAY switch except for B DLY'D, -8 volts is connected to the cathode of CR1341. This pulls the anode of CR1306 down very close to -8 volts, causing CR1306 to be reverse biased, which in turn allows the gate signal at the collector of Q1306 to pass through CR1342. In the B DLY'D position of the HORIZ DISPLAY switch, -8 volts is no longer connected to CR1341. This allows CR1306 to be forward biased, which pulls up on the cathode of CR1342. This reverse-biases CR1342, which blocks the A blanking signal from reaching the Z-Axis Amplifier.

In all positions of the HORIZ DISPLAY switch except MIX, -8 volts is connected to the cathode of CR832. This keeps CR831 reverse biased and prevents the collector signal of Q824 from affecting the A Z-Axis Gate. However,

in the MIX position of the HORIZ DISPLAY switch, -8 volts is no longer connected to CR832. Now, when the B Sweep ends and sets the B Sweep Latch circuit, the collector signal of Q824 (through CR831) switches the A Sweep Z-Axis Gate causing the CRT display to be completely blanked. This prevents any further display of A Sweep in the MIX mode even though A Sweep may still be running.

B Sweep Z-Axis Gate

Q1324 and Q1326 compose the B Sweep Z-Axis Gate. They form an emitter-coupled stage where normally one transistor is on and the other is off. The controlling signal inputs come from the collector of Q812 in the B Sweep Gate and the blanking signal from Q1074 in the B Sweep Generator. The blanking signal for use in the Z-Axis Amplifier is taken from the collector of Q1326 (through CR1344). The collector signal of Q1324 is applied to the +B GATE Emitter Follower.

In the A position of the HORIZ DISPLAY switch, -8 volts is applied to the cathode of CR1347, which causes CR1345 to be back biased. The collector of Q1326 is pulled positive through R1326 and CR1326, which in turn back biases CR1344, preventing the B Sweep Z-Axis Gate from affecting CRT unblanking. In the MIX and A INTEN positions of the HORIZ DISPLAY switch, -8 volts is removed from the cathode of CR1347 and applied to the cathode of CR1327. This forward biases CR1345 and reverse biases CR1326. CR1344 is still reverse biased, but when B Sweep starts, the collector of Q1326 steps negative enough to forward bias CR1344 and add a slight amount of unblanking to the A Sweep unblanking already present. This provides a measure of intensification for the B Sweep portion of an A INTEN or MIX display. In the B DLY'D position of the HORIZ DISPLAY switch, -8 volts is applied to the cathodes of CR1327 and CR1347. This reverse biases both CR1345 and CR1326, which allows the full B Sweep unblanking signal to pass through CR1344. Since the A Sweep Z-Axis Gate output diode CR1342 is held reverse biased, the only unblanking signal present at the input to the Z-Axis Amplifier will be the B Sweep signal.

+A GATE And +B GATE Emitter Followers

Q1314 and Q1334 are emitter followers providing the +A GATE and +B GATE output signals available at the instrument rear panel. The output signals are positive-going rectangular waveforms, approximately 5.5 volts in amplitude. The amplitude is set in the collectors of Q1304 and Q1324. For example, when Q1304 is conducting the base of Q1314 can go no more negative than approximately -0.7 volt (limited by CR1304). When Q1304 is not conducting, the base of Q1314 rises to the decoupled +5 volts power supply level through R1304. CR1315, CR1316,

CR1335, and CR1336 provide protection against accidental application of damaging voltage levels to the +A GATE and +B GATE output connectors.

B Sweep Latch

Q822 and Q828 compose the B Sweep Latch. Quiescently, (before either the A or B Sweeps have reached their maximum amplitudes) both transistors are off. Then, the sweep reset pulse from whichever sweep terminates first will be applied to the base of Q828 (A Sweep reset through CR826; B Sweep reset through CR825). The positive-going reset pulse turns on Q828 and the negative-going movement at its collector turns on Q822. The collector of Q822 in turn pulls up on the base of Q828, holding Q828 on, which causes the circuit to stay in its on or latched state. The HI at the collector of Q822 is applied to the base of the B Sweep Holdoff Amplifier (through CR809) to disable the B Trigger Tunnel Diodes. In the B ENDS A position of the A TRIG HOLDOFF control the HI is also applied to the holdoff start input terminal of the Sweep Control IC through C286. Thus, when B Sweep ends A Sweep ends also.

The B Latch Multivibrator is reset to its quiescent state by the LO Holdoff level Present at pin 10 of the Sweep Control IC during A Sweep holdoff.

HORIZONTAL AMPLIFIER

General

The Horizontal Amplifier circuit provides the output signals to the CRT horizontal deflection plates. The signal applied to the input of the Horizontal Amplifier is determined by the TIME/DIV switch. The signal can be a sawtooth waveform generated within the instrument, or some external signal applied to the CH 1 OR X input connector (X-Y mode of operation). The Horizontal Amplifier also contains the X10 magnifier, horizontal positioning, and some beam finder circuitry. Fig. 3-7 shows a detailed block diagram of the Horizontal Amplifier circuit. A schematic of this circuit is shown on diagram 9 at the rear of this manual.

X-Axis Amplifier

In all positions of the TIME/DIV switches except X-Y, the input signal to the base of Q1224 will be the sawtooth waveforms from the sweep generators. In the X-Y mode however, the sweeps are disabled and the signal applied to Q1224 comes from the Channel 1 Preamp via the X-Axis Amplifier stage. This stage includes Q1214, Q1218, and their associated circuitry.

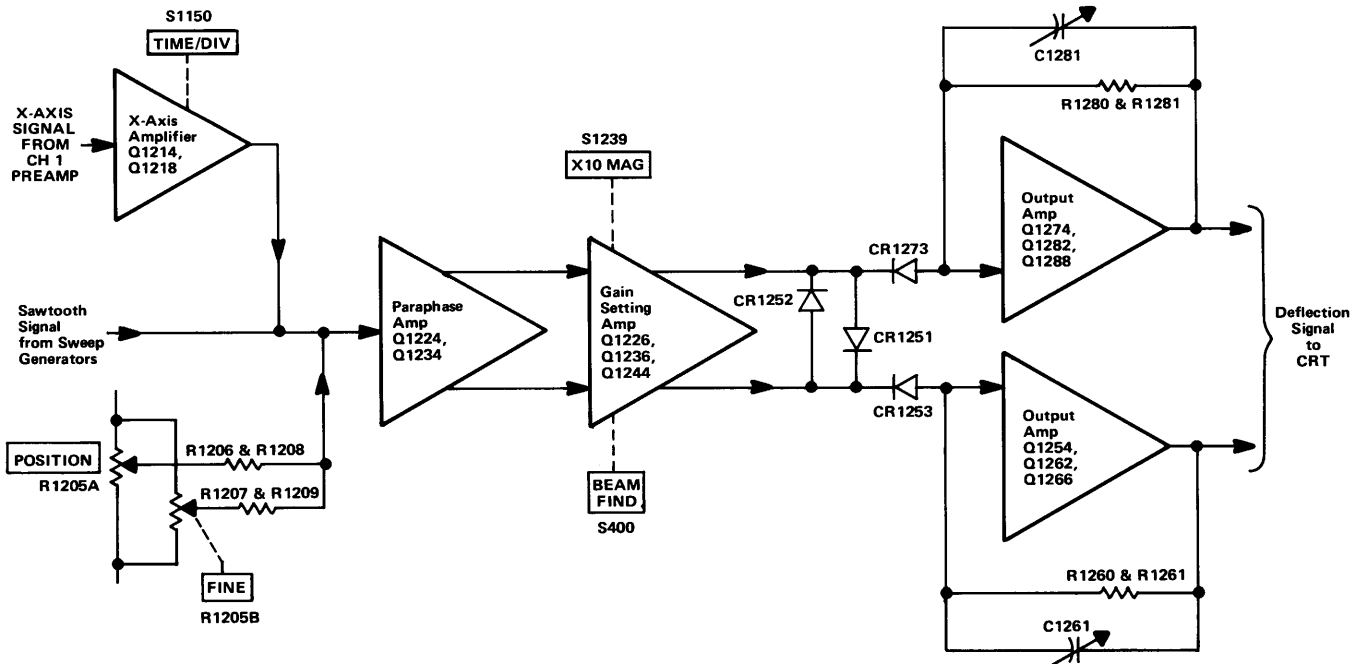

Fig. 3-7. Detailed block diagram of the Horizontal Amplifier.

Q1214 is connected as a feedback amplifier with R1214 as the feedback element. The input resistance is made up of R1211 and the gain-setting adjustment R1215. When not operating in the X-Y mode, the base of Q1214 rises toward the +15 volt supply but is clamped at approximately +5.7 volts by CR1216. This reverse biases the base-emitter junction of Q1214. The base of Q1218 also rises to approximately +5.7 volts. With the junction of R1202-R1219 sitting at approximately 0 volts, Q1218 is also biased off.

When the TIME/DIV switches are set to the X-Y position (fully counterclockwise), -8 volts is applied to the junction of R1212 and R1217. Also, +5 volts is applied to the emitter circuit of Q1218 through CR1202. This biases the Z-Axis Amplifier circuit into conduction. At the same time, +5 volts is applied to the Channel 1 Scale-Factor Switching Amplifier circuit (through CR1201) and to pin 18 of the Sweep Control Integrated Circuit U870. This enables both scale-factor indicating circuits at the same time and disables sweep generation.

Input Paraphase Amplifier

Q1224 and Q1234 compose the Input Paraphase Amplifier. This is an emitter-coupled amplifier stage that converts the single-ended input signal to a push-pull output signal. The signal at the collector of Q1224 is opposite in phase to the input signal. The signal at the collector of Q1234 is in phase with the input signal. Thermistor resistor RT1230 reduces in value with increases in ambient temperature to increase the gain of the stage. This compensates for changes in amplifier gain that occur as operating temperatures vary. R1205A and R1205B are the Horizontal POSITION and FINE controls, respectively. The FINE control has approximately one tenth the range of the POSITION control and provides fine adjustment of a magnified display.

Gain Setting Amplifier

Q1226 and Q1236 are an emitter coupled push-pull amplifier stage. Q1244 is a constant current supply for the stage. The gain of the Horizontal Amplifier is controlled by adjusting the resistance connected between the emitters of this stage. The X1 Gain adjustment R1237 adjusts unmagnified horizontal gain and the X10 Gain adjustment R1238 adjusts magnified horizontal gain. Magnifier Registration adjustment R1225 balances quiescent DC current in Q1226 and Q1236 so that a center screen display does not change position when the X10 Magnifier is turned on.

When the BEAM FIND pushbutton is pressed, R1249 is connected to ground. This reduces the current supplied through Q1244, which has the effect of shifting the operating level at the collector of Q1244 in the positive direction. This causes the Horizontal Amplifier to operate closer to the point where signal limiting occurs, thereby ensuring that an overscanned display will remain within the viewing area of the CRT.

Output Amplifier

The push-pull signal from the Gain Setting Amplifier is connected to the Output Amplifier through CR1253 and CR1273. Each half of the Output Amplifier can be considered as a single-ended feedback amplifier, which amplifies the signal current at the input to produce a voltage output to drive the horizontal deflection plates of the CRT. The amplifiers have a low input impedance and require very little voltage change at the input to produce the desired output change. The Output Amplifiers are limited from overdrive by CR1251, CR1252, CR1253, and CR1273. The input diodes CR1253 and CR1273 become back-biased when the signal level at either input becomes too positive, and the diodes connected back to back between the two signal paths ensure that the signal amplitude side to side will be limited to a maximum of about 0.7 volt.

Transistors Q1254 and Q1274 are inverting amplifier stages whose collector signals drive the emitters of complementary amplifiers Q1262-Q1266 and Q1282-Q1288 respectively. C1256, C1262, and C1282 provide a signal path for fast AC signal currents from one side of the amplifier to the other. R1260-R1261 and R1280-R1281 are the feedback elements in the amplifier with C1261 and C1281 providing high-frequency compensation. The output signal from Q1262-Q1266 drives the right CRT deflection plate, while the signal from Q1282-Q1288 drives the left.

CRT CIRCUIT

General

The CRT Circuit provides the voltage levels and control circuits necessary for operation of the cathode-ray tube (CRT). Fig. 3-8 shows a detailed block diagram of the CRT Circuit. A schematic of this circuit is shown on diagram 10 at the rear of this manual.

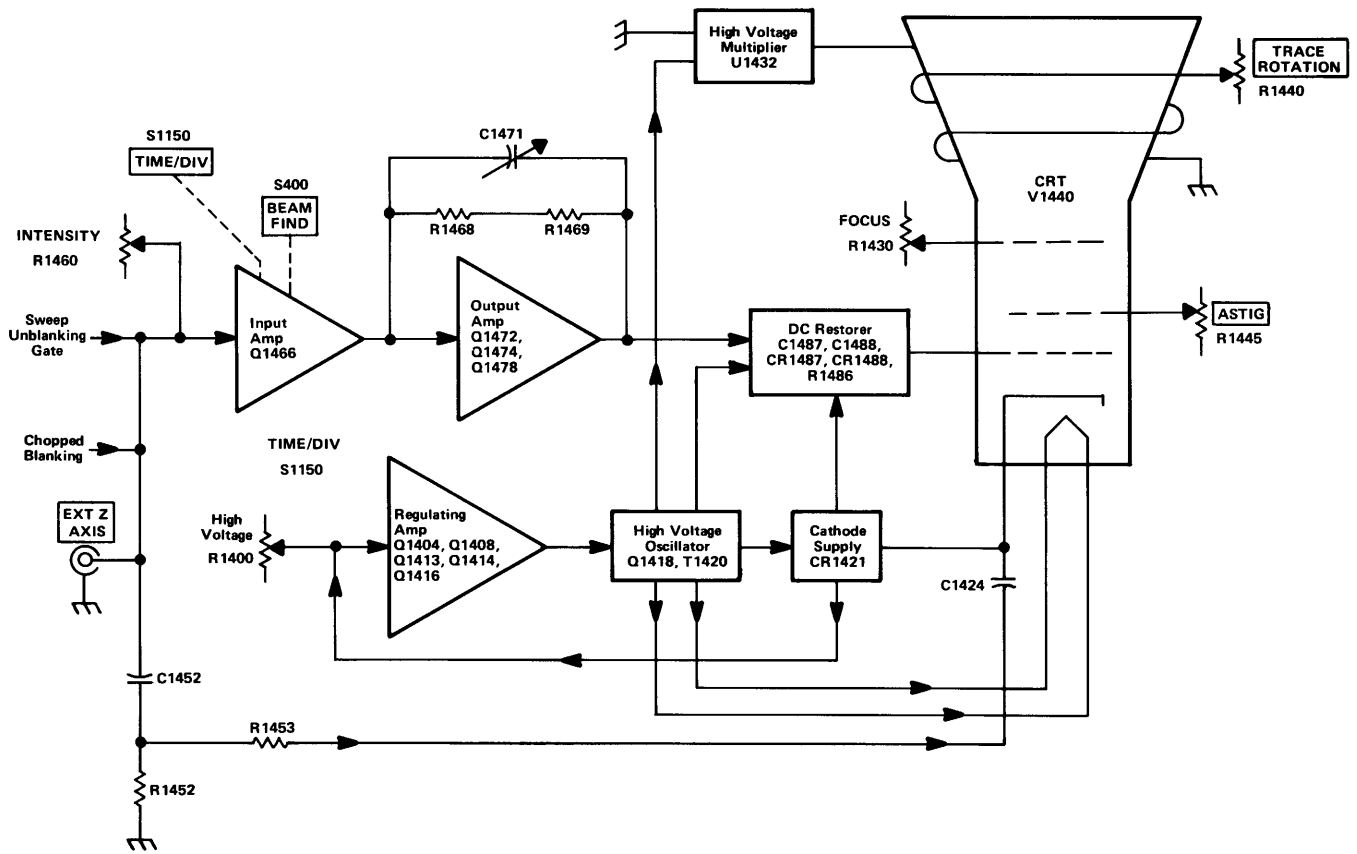

Fig. 3-8. Detailed block diagram of the CRT & Z-AXIS Circuits.

High-Voltage Oscillator

Q1418 and associated circuitry compose the high-voltage oscillator that produces the drive for high-voltage transformer T1420. When the instrument is turned on, current through Q1416 provides forward bias for Q1418. Q1418 conducts and the collector current increases, which develops a voltage across the collector winding of T1420. This produces a corresponding voltage increase in the feedback winding of T1420, which is connected to the base of Q1418, and Q1418 conducts even harder. Eventually the rate of collector current increase in Q1418 becomes less than that required to maintain the voltage across the collector winding, and the output voltage drops. This turns off Q1418 by way of the feedback voltage to the base. The voltage waveform at the collector of Q1418 is a sine wave at the resonant frequency of T1420. Q1418 remains off during the negative half cycle while the field collapses in the primary of T1420. When the field is collapsed sufficiently, the base of Q1418 becomes forward biased into conduction again and the cycle begins anew. The amplitude of sustained oscillation depends upon the average current delivered to the base of Q1418. The frequency of oscillation is approximately 50 kilohertz. Fuse F1419 protects the +15 volt supply in the event the High-Voltage Oscillator stage becomes shorted. C1419 and L1419 decouple the +15

volt supply line and prevent the current changes present in the circuit from affecting the +15 volt regulator.

High-Voltage Regulator

Feedback from the CRT cathode -2450 volt supply is applied to the base of Q1404 through R1431D. Any change in the level at the base of Q1404 produces an error signal at the collector of Q1404, which is amplified by Q1408 and Q1416 and applied to the base of Q1418 through the feedback winding of T1420. Regulation occurs as follows.

If the output voltage at the -2450 volt test point starts to go positive (less negative), this positive-going change is applied to the base of Q1404. Q1404 conducts harder, which in turn causes Q1408 and Q1416 to conduct harder. This results in greater bias current to the base of Q1418 through the feedback winding of T1420. Now, Q1418 is biased closer to its conduction level so that it comes into conduction sooner to produce a larger induced voltage in the secondary of T1420. This increased voltage appears as a more negative voltage at the -2450 volt test point to correct the original positive-going change. By sampling the

output from the CRT cathode supply in this manner, the total output of the High-Voltage Supply is held relatively constant.

The output voltage levels of the High-Voltage Supply are controlled by the High Voltage Adjustment R1400 in the base circuit of Q1404. This adjustment sets the conduction of Q1404 to a level that establishes a -2450 volt operating potential at the CRT cathode.

Q1413 and Q1414 compose an overvoltage protection circuit. In the event the regulating action of the circuit should cause the CRT cathode supply to approach approximately -3000 volts, the voltage level at the emitter of Q1416 will be very close to -6 volts. Normally Q1413 and Q1414 are biased off and do not conduct. When the voltage level at the emitter of Q1416 reaches approximately -6 volts, Q1413 is biased into conduction which in turn biases Q1414 on. Q1414 now starts to reduce the base drive applied to Q1418 and prevents the amplitude of oscillations from increasing. This prevents the CRT cathode supply from going more negative than approximately -3000 volts.

High-Voltage Rectifiers and Output

The high-voltage transformer T1420 has two output windings. One winding provides filament voltage for the cathode-ray tube. The filament voltage can be supplied from the High-Voltage Supply, since the cathode-ray tube has a very low filament current drain. The cathode and filament of the CRT are connected together to elevate the filament and prevent cathode-to-filament breakdown. One high-voltage winding provides both the negative cathode potential and the positive anode accelerating voltage. The CRT grid bias voltage is derived by a DC restorer circuit that uses a sample of the signal in the high-voltage winding in conjunction with DC levels supplied by the Z-Axis Amplifier and the negative cathode potential.

The positive accelerating potential is supplied by High Voltage Multiplier U1432. Regulated output voltage is approximately +15,500 volts. The negative cathode potential is supplied by half-wave rectifier CR1241. Voltage output is -2450 volts. Voltage variations in this supply are monitored by the High-Voltage Regulator circuit to provide a regulated high-voltage output.

CRT Control Circuits

Focus of the CRT display is controlled by FOCUS control R1430. ASTIG adjustment R1445, which is used in conjunction with the FOCUS control to provide a well-defined display, varies the positive level on the astigmatism grid. Geometry adjustment R1442 varies the positive level

on the horizontal deflection plate shields to control the overall geometry of the display.

Two adjustments control the trace alignment by varying the magnetic field around the CRT. Y Axis adjustment R1446 controls the current through L1446, which affects the CRT beam after vertical deflection, but before horizontal deflection. Therefore, it affects only the vertical (Y) components of the display. TRACE ROTATION adjustment R1440 controls the current through L1440 and affects both vertical and horizontal rotation of the beam.

Z-Axis Amplifier

The Z-Axis Amplifier circuit controls the CRT intensity level from several inputs. The effect of these input signals is to either increase or decrease the trace intensity, or to completely blank portions of the display. The input transistor Q1466 is a current-driven, low input impedance amplifier. It provides termination for the input signals as well as isolation between the input signals and the following stages. The current signals from the various control sources are connected to the emitter of Q1466 and the algebraic sum of the signals determines the collector conduction level.

Q1472, Q1474, and Q1478 compose a feedback amplifier stage; R1468 and R1469 are the feedback elements. C1469 and C1471 provide high frequency compensation. Q1472 is an emitter follower providing drive to complementary amplifier Q1474-Q1478. CR1468, CR1472, and CR1476 provide protection in the event of high-voltage arcing.

In the .1 s, .2 s, .5 s, and X-Y positions of the TIME/DIV switch, +5 volts is connected to the anode of CR1463. This limits the effective range of the INTENSITY control to reduce the unblanking capabilities of the amplifier, thereby reducing the possibility of inadvertently burning the CRT phosphor. When the BEAM FIND pushbutton is pressed, two things occur: First, +15 volts is applied to the anode of CR1465 which lifts the emitter of Q1466 sufficiently positive to ensure there will be no conduction through Q1466. Secondly, R1470 becomes connected to -8 volts through R1477 which establishes a fixed predetermined unblanking level at the output of the amplifier. Thus, the INTENSITY control and all of the input unblanking signals have no control over the intensity level of the CRT display when the BEAM FIND pushbutton is pressed.

DC Restorer Circuit

C1488, C1487, CR1487, CR1488, and R1486 form a DC restorer circuit. All DC levels in this circuit are

referenced to the negative potential of the CRT cathode. The voltage difference across R1486 approximately equals the voltage swing present at the junction of CR1482 and CR1483. The control grid end of R1486 is more negative than the end connected to CR1488. The amplitude of the voltage swings present at the junction of CR1482 and CR1483 is determined by the voltage levels established by the Z-Axis Amplifier and the CRT Bias adjust circuit. CR1483 sets the limit of the positive excursion and CR1482 sets the limit of the negative excursion.

CALIBRATOR

General

The Calibrator circuit produces a square-wave output signal with accurate voltage and current amplitudes. This output is available as a voltage or current at the CALIBRATOR current loop on the instrument front panel. Fig. 3-9 shows a detailed block diagram of the Calibrator circuit. A schematic of this circuit is shown on diagram 11 at the back of this manual.

Multivibrator

Q1590 and Q1594 along with their associated circuitry compose an astable multivibrator. The basic frequency of the multivibrator is approximately one kilohertz and is essentially determined by the RC combination of C1592, R1591, and R1593. Q1590 and Q1594 alternately conduct, producing a square-wave output signal, which is taken from the collector of Q1594. The amplitude of the square wave is limited in the negative direction by the base-emitter junction of Q1598 and in the positive direction by CR1596.

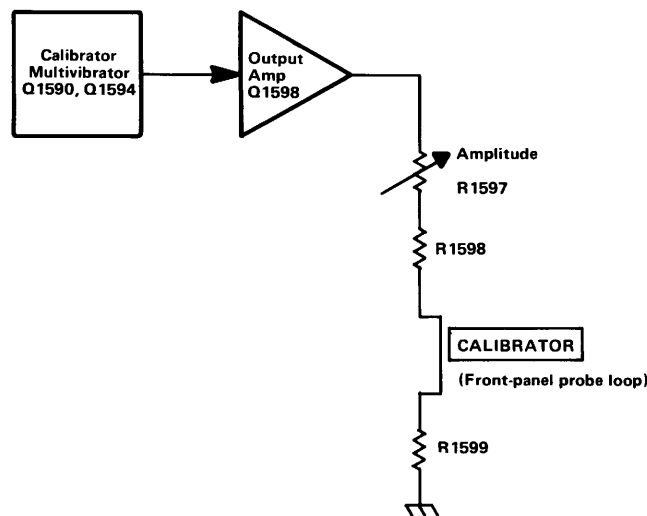

Fig. 3-9. Detailed block diagram of the Calibrator circuit.

Output Amplifier

The output signal from the Multivibrator overdrives Output Amplifier Q1598 to produce an accurate square wave at the output. When the base of Q1598 goes positive Q1598 is cut off and the collector level drops down to ground. When the base goes negative Q1598 is biased into saturation and the collector of Q1598 rises positive to about +5 volts. Amplitude adjustment R1597 adjusts the resistance between the collector of Q1598 and ground to determine the amount of current allowed to flow, which in turn determines the voltage developed across R1599.

A TRIGGER VIEW AMPLIFIER

General

The A Trigger View Amplifier circuit amplifies a sample of the signal present in the A Trigger Generator circuit and passes it on to the Vertical Output Amplifier for display on the CRT when the TRIG VIEW pushbutton is pressed. This provides a method of making a quick and convenient check of the signal being used to trigger the A Sweep Generator and is intended primarily to be used to check the signal applied to the A External Trigger Input connector. Fig. 3-10 shows a detailed block diagram of the A Trigger View Amplifier circuit. A schematic of this circuit is shown on diagram 11 at the back of this manual.

Amplifier

The amplifier consists of two emitter-coupled push-pull amplifier stages. The emitter source voltage for Q672 and Q682 is switched on and off by the TRIG VIEW pushbutton. With the TRIG VIEW pushbutton not pressed, the emitters of Q672 and Q682 are returned to -8 volts through R691. This reverse-biases the base-emitter junctions of the transistors, preventing any loading of the A Trigger Generator circuit. When the TRIG VIEW pushbutton is pressed, the emitters of Q672 and Q682 are returned to +15 volts through R690. This forward biases

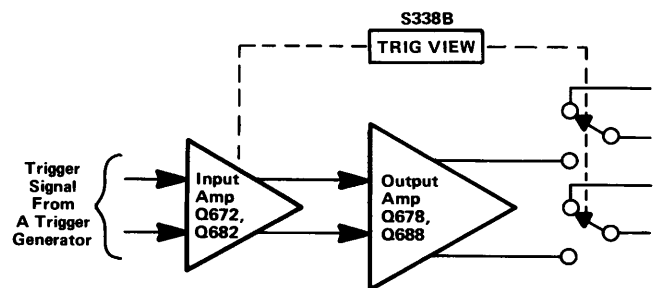

Fig. 3-10. Detailed block diagram of the Trigger View Amplifier.

Q672 and Q682 to allow signal amplification. R675 adjusts for correct DC balance in the circuit.

Normally, the output of the Vertical Switching Amplifier is applied to the input of the Delay Line. When the TRIG VIEW pushbutton is pressed, the signal from the Vertical Switching Amplifier is removed and the output from the A Trigger View Amplifier is applied in its place.

LOW-VOLTAGE POWER SUPPLY

General

The Low-Voltage Power Supply circuit provides the operating power for this instrument from four regulated supplies and one unregulated supply. Electronic regulation is used to provide stable, low-ripple output voltages. Fig. 3-11 shows a detailed block diagram of the Power Supply circuit. A schematic of this circuit is shown at the back of this manual.

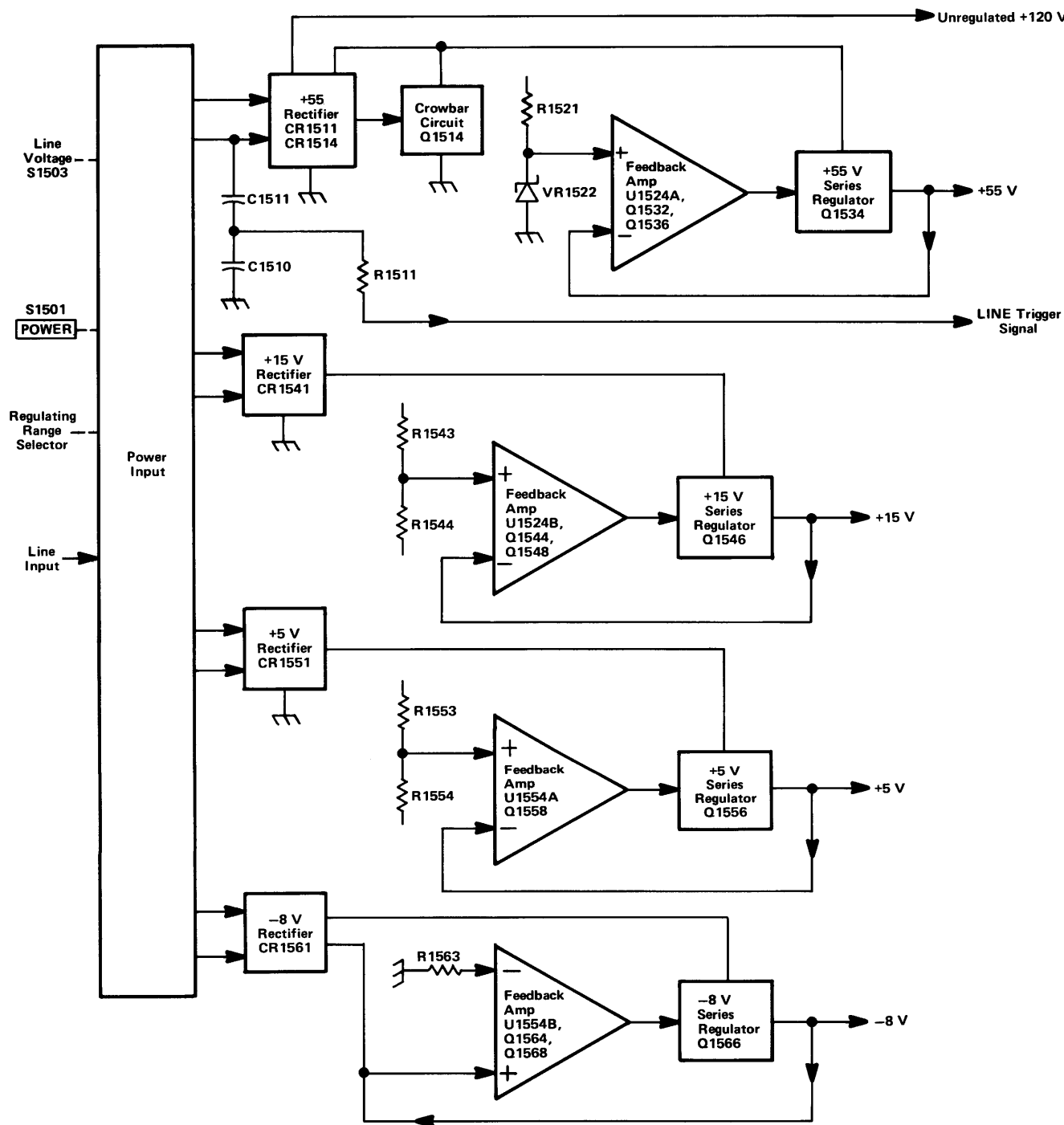

Fig. 3-11. Detailed block diagram of the Low Voltage Power Supply.

Circuit Description—465

Power Input

Power is applied to the primary of transformer T1501 through Line Fuse F1501, POWER switch S1501, Thermal Cutout S1502, Line Voltage Selector switch S1503, and the Regulating Range Selector Assembly. Line Voltage Selector switch S1503 connects the split primaries of T1501 in parallel for 115-volt nominal operation, or in series for 230-volt nominal operation. Line Fuse F1501 should be changed to the correct value to provide the correct protection for each nominal line voltage (current rating of fuse for 230-volt operation is one-half the current rating of fuse for 115-volts).

The vacant windings between pins 10, 11, and 12 of T1501 are intended for use with the optional Inverter Circuit Board (Option 7). This allows the instrument to be operated from an external DC power source or an 1106 Power Supply.

Secondary Circuit

The -8 volt, +5 volt, +15 volt, and +55 volt supplies are series-regulated supplies. U1524A and B and U1554A and B are high-gain amplifier cells with differential inputs. These amplifiers monitor voltage variations in the output voltages and generate error signals to maintain relatively constant output voltages. Additionally an unregulated +120 volt supply is derived from the unregulated voltage in the +55 volt supply.

R1515, R1516, VR1515, and Q1514 compose a Crowbar circuit. This circuit provides protection in the event,

that the applied line voltage exceeds the upper limit selected by the Regulating Range Selector Assembly. When over-voltage conditions occur, Q1514 is triggered on and starts to conduct. This places a very low impedance directly across the output of CR1511, which now begins to conduct heavily, and eventually causes the line fuse F1501 to blow.

C1510, C1511, and R1511 compose a wave-shaping circuit that provides a sample of the AC voltage present in the secondary of T1501 to the trigger circuitry for use in the LINE positions of the Trigger SOURCE switches. CR1512 provides a relatively fast discharge path for C1542 when instrument power is turned off.

FAN MOTOR CIRCUIT

General

The fan motor used in the 465 is a brushless DC fan motor using Hall Effect devices. The fan motor circuitry varies the rotational speed of the fan with variations in operating temperature. When the ambient temperature increases, the value of thermistor RT1696 reduces. This biases Q1698 on harder to conduct more current through the Hall devices. Higher currents through the Hall devices causes the potential difference across them (for instance, between pins 6 and 8 of the fan) to increase. This potential difference biases one of a pair of transistors on and the other off. For instance, if pin 8 is more positive than pin 6 of the fan, Q1690A will be on and Q1690D will be off. The higher the potential difference between pin 8 and pin 6 the harder the on transistor will be conducting. The harder the transistor is conducting, the faster the fan rotates.

MAINTENANCE

Cabinet Removal

WARNING

Dangerous potentials exist at several points throughout this instrument. When the instrument is operated with the cover removed, do not touch exposed connections or components. Some transistors may have elevated cases. Disconnect power before cleaning the instrument or replacing parts.

The instrument wrap-around cabinet can be removed in the following manner:

1. Unwrap the power cord from the instrument feet.
2. Remove the six screws indicated in Fig. 4-1 and remove the instrument feet and rear ring assembly from the instrument.
3. Slide the wrap-around cabinet to the rear and remove the oscilloscope.

To replace the instrument in its wrap-around cabinet, reverse the removal procedure. The portable wrap-around cabinet should be installed with the carrying handle pivot points positioned toward the bottom of the instrument.

PREVENTIVE MAINTENANCE

General

Preventive maintenance consists primarily of cleaning and visual inspection. When performed on a regular basis, preventive maintenance can prevent instrument breakdown and will improve the reliability of this instrument. The severity of the environment to which the 465 is subjected will determine the frequency of maintenance. A convenient time to perform preventive maintenance is just prior to recalibration of the instrument.

Cleaning

General. The 465 should be cleaned as often as operating conditions require. Accumulation of dirt in the instrument can cause overheating and component breakdown. Dirt on

components acts as an insulating blanket and prevents efficient heat dissipation. It also provides an electrical conduction path which can result in instrument failure.

The cabinet provides protection against dust in the interior of the instrument. Operation without the cabinet in place necessitates more frequent cleaning. The front cover provides a measure of dust protection for the front panel and the CRT face. The front cover should be installed when storing or transporting the instrument.

CAUTION

Avoid the use of chemical cleaning agents which might damage the plastics used in this instrument. Avoid chemicals which contain benzene, toluene, xylene, acetone or similar solvents. Recommended cleaning agents are isopropyl alcohol or Kelite (1 part Kelite, 20 parts water).

Switch Contacts. Most of the switching in the 465 is accomplished with circuit-board mounted, cam-actuated contacts. Care must be exercised to preserve the high-frequency characteristics of these switches. Seldom is switch maintenance necessary, but if it is required, observe the following precautions.

Cleaning the switch contacts should only be done using isopropyl alcohol or a solution of one part Kelite to 20 parts water. In the absence of these three cleaners it is safe to use petroleum ether, white kerosene, or a solution of 1% Joy detergent and 99% water. Do not use acetone, MEK, MIBK, benzol, toluol, carbon tetrachloride,

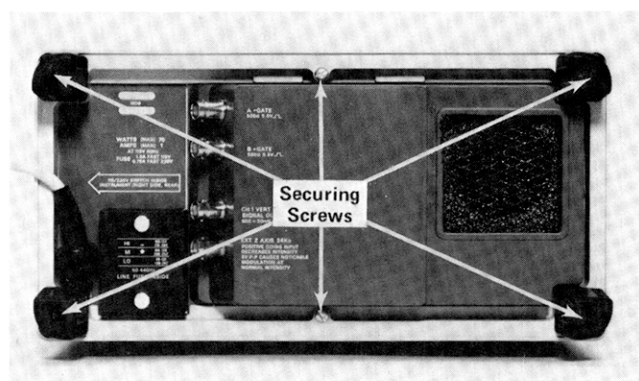

Fig. 4-1. Removing wrap-around cabinet.

trichlor, trichlene, methyl alcohol, methylene chloride, sulfuric acid, or Freon TC-TE-TF-22-TA-12.

Most spray circuit coolants and contact cleaners contain Freon 12 as a propellant. Because many Freons adversely affect the contacts, check the contents before using a spray cleaner or coolant. An acceptable contact cleaner-restorer is No Noise (Electronic Chemical). The only recommended circuit coolants are dry ice or isopropyl alcohol. There are three recommended switch lubricants. They are Silicone Versilube (General Electric Co.), Rykon R (Standard Oil, and WD-40 (Rocket Chemical Co.).

Exterior. Loose dust accumulated on the outside of the 465 can be removed with a soft cloth or small paint brush. The paint brush is particularly useful for dislodging dirt on and around the front-panel controls. Dirt which remains can be removed with a soft cloth dampened in a mild detergent and water solution. Abrasive cleaners should not be used.

CRT. Clean the blue and clear plastic light filters and the CRT face with a soft, lint-free cloth dampened with denatured alcohol or a mild detergent and water solution. The optional CRT mesh filter can be cleaned in the following manner.

1. Hold the filter in a vertical position and brush lightly with a soft No. 7 watercolor brush to remove light coatings of dust and lint.
2. Greasy residues or dried-on dirt can be removed with a solution of warm water and a neutral pH liquid detergent. Use the brush to lightly scrub the filter.
3. Rinse the filter thoroughly in clean water and allow to air dry.
4. If any lint or dirt remains, use clean low-pressure air to remove. Do not use tweezers or other hard cleaning tools on the filter as the special finish may be damaged.
5. When not in use, store the mesh filter in a lint-free dust-proof container such as a plastic bag.

Interior. Dust in the interior of the instrument should be removed occasionally due to its electrical conductivity under high-humidity conditions. The best way to clean the interior is to blow off the accumulated dust with dry,

low-pressure air. Remove any dirt that remains with a soft paint brush or a cloth dampened with a mild detergent and water solution. A cotton-tipped applicator is useful for cleaning in narrow spaces or for cleaning circuit boards.

Lubrication

The fan motor and most of the potentiometers used in the 465 are permanently sealed and generally do not require periodic lubrication. The switches used in the 465, both cam- and lever-type, are installed with proper lubrication applied where necessary and will only rarely require any additional lubrication. It is recommended that a regular periodic lubrication program not be performed on any of the components used in the 465.

Transistor Checks

Periodic checks of the transistors and other semiconductors in the 465 are not recommended. The best check of semiconductor performance is actual operation in the instrument.

Recalibration

To assure accurate measurements, check the calibration of this instrument after each 1000 hours of operation or every six months if used infrequently. In addition, replacement of components may necessitate recalibration of the affected circuits. Complete calibration instructions are given in the Calibration section.

The calibration procedure can also be helpful in localizing certain troubles in the instrument. In some cases, minor troubles may be revealed or corrected by recalibration.

CORRECTIVE MAINTENANCE

General

Corrective maintenance consists of component replacement and instrument repair. Special techniques required to replace components in this instrument are given here.

Obtaining Replacement Parts

Standard Parts. All electrical and mechanical part replacements for the 465 can be obtained through your local TEKTRONIX Field Office or representative. However, many of the standard electronic components can be obtained locally in less time than is required to order them

from Tektronix, Inc. Before purchasing or ordering replacement parts, check the parts list for value, tolerance, rating, and description.

NOTE

When selecting replacement parts, it is important to remember that the physical size and shape of a component may affect its performance in the instrument, particularly at high frequencies. All replacement parts should be direct replacements unless it is known that a different component will not adversely affect instrument performance.

Special Parts. In addition to the standard electronic components, some special components are used in the 465. These components are manufactured or selected by Tektronix, Inc. to meet specific performance requirements, or are manufactured for Tektronix, Inc. in accordance with our specifications. These special components are indicated in the Electrical Parts List by an asterisk preceding the part number. Most of the mechanical parts used in this instrument have been manufactured by Tektronix, Inc. Order all special parts directly from your local TEKTRONIX Field Office or representative.

Ordering Parts. When ordering replacement parts from Tektronix, Inc., it is imperative that all of the following information be included in the order to ensure receiving the proper parts.

1. Instrument type.
2. Instrument serial number.
3. A description of the part (if electrical, include the circuit number).
4. TEKTRONIX Part number.

Soldering Techniques

WARNING

Always disconnect the instrument from the power source before attempting to solder in the instrument.

Ordinary 60/40 solder and a 35- to 40-watt pencil-type soldering iron can be used to accomplish the majority of the soldering to be done in the 465. If a higher wattage-rated soldering iron is used on the etched circuit boards, excessive heat can cause the etched circuit wiring to separate from the board base material.

CAUTION

The Vertical Preamplifier Attenuator circuit boards are made of material easily damaged by excessive heat. When soldering to these boards, do not use a

soldering iron with a rating of more than approximately 15 watts. Avoid prolonged applications of heat to circuit-board connections. Use only isopropyl alcohol when cleaning this circuit board.

When soldering to the ceramic strips in the instrument a slightly larger soldering iron can be used. It is recommended that a solder containing about 3% silver be used when soldering to these strips to avoid destroying the bond to the ceramic material. This bond can be broken by repeated use of ordinary tin-lead solder or by the application of too much heat; however, occasional use of ordinary solder will not break the bond if excessive heat is not applied.

If it becomes necessary to solder in the general area of any of the high-frequency contacts in the instrument, clean the contacts immediately upon completion of the soldering. Refer to the section entitled Switch Contacts under PREVENTIVE MAINTENANCE for recommended cleaners and procedures.

Component Replacement

WARNING

Always disconnect the instrument from the power source before attempting to replace components.

Circuit Board Replacement. Occasionally it may be necessary to gain access to the reverse side of a circuit board or to remove one circuit board to gain access to another. The following procedures outline the necessary steps to facilitate instrument disassembly. Most of the connections to the circuit boards in the instrument are made with pin connectors. However, some connections are soldered to the board. Observe the soldering precautions given under Soldering Techniques in this section.

Vertical Preamp Assembly Removal.

1. Remove the instrument wrap-around cabinet in the manner given under Cabinet Removal earlier in this section.
2. Remove the knobs from the VOLTS/DIV switches and from the Input Coupling Switches. The knobs on the VOLTS/DIV switches must have a setscrew in each one loosened (using a 1/16" Allen wrench) before they can be removed, while the knobs on the Input Coupling switches can be pulled off by hand.
3. Disconnect the vertical POSITION control shaft couplers from the vertical POSITION potentiometers (.050" Allen wrench required).

4. Remove the two UNCAL light lenses. Pry them away from the front panel with a fingernail and pull them straight out.

5. Disconnect the following cables from the Vertical Preamp circuit board:

a. Nine coaxial cables (five on the front and four on the back). Make note of cable color-codes to insure proper installation during reassembly.

b. A six-wire ribbon cable that connects to the Interface board (P300).

c. The delay-line that connects to the Vertical Output Amplifier.

d. An eight-wire ribbon cable that plugs onto the Vertical Mode Switch circuit board (P390).

6. Remove the covers from the attenuators.

7. Unsolder the leads to both input coupling capacitors. Remove the capacitors by unplugging them from the attenuator circuit boards.

8. Remove the four nuts securing the attenuator chassis to the instrument front casting (1/4" nutdriver required).

9. Remove the circuit board hold down screw on the Vertical Mode Switch circuit board (accessible through a hole in the Vertical Preamp circuit board near the Channel 1 POSITION potentiometer; pozidrive screwdriver required).

10. Remove three circuit board hold down screws from the Vertical Preamp circuit board (two at the rear and one below the Channel 2 POSITION potentiometer).

11. Remove the Vertical Preamp, cam switch assembly, and Vertical Mode Switch circuit board as a unit. Pull the rear of the Vertical Preamp circuit board outward about one or two inches; then slide the whole assembly to the rear until the front-panel control shafts clear the front casting.

To reinstall the Vertical Preamp assembly, reverse the order of the removal steps. To align the VERT MODE switch pushbuttons, hold the assembly in place with a slight forward pressure and use some sort of small tool to reach through the front panel to align the buttons. Install the remaining parts in the reverse order they were removed. Do not tighten the circuit board hold down screws until the

securing nuts at the front of the attenuator chassis are tight and the circuit board is aligned properly.

Trigger Circuit Board Removal.

1. Remove the LOW LINE, READY, and TRIG light lenses from the front panel. Pry them away from the front panel with a fingernail and pull straight out.

2. Disconnect the following cables:

a. Eight coaxial cables (five on the front and three on the back; two on the front will have to be unsoldered). Make note of cable color-codes to ensure proper installation during reassembly.

b. Three ribbon cables (two five-wire and one two-wire) from the Trigger Generator & Sweep Logic circuit board (P530, P630, and P1040).

3. Unsolder the two wires from the circuit board that run to the A TRIG HOLDOFF control and the two connections to the External Trigger Input connectors. Make note of wire color-codes to ensure proper installation during reassembly.

4. Remove the POWER switch actuator rod from the plastic holder on the switch. Pry the rod out of the holder with a small flat-bladed screwdriver.

5. Remove the POWER switch bracket from the circuit board (1/4" wrench or nutdriver required).

6. Remove five mounting screws from the circuit board (two at rear, two at front, and one at center-top; pozidrive screwdriver required).

7. Unplug the Trigger Generator & Sweep Logic circuit board from the Interface Board by forcing the Trigger board away at the two white interboard connectors at the bottom edge of the Trigger board.

8. Move the Trigger board to the rear until the Trigger switches clear the front casting and then remove the assembly from the instrument. Exercise caution to avoid damaging the connector pins on the Interface Board.

To reinstall the Trigger Generator & Sweep Logic circuit board, reverse the order of the removal steps. If the indexing of the Trigger switches was disturbed, a series of

trial-and-error installation-removal-adjustment steps will be necessary to return them to correct alignment.

Sweep Timing Circuit Board Removal.

1. Remove the Trigger Generator & Sweep Logic circuit board as outlined above.

2. Unsolder four wires from the Timing circuit board. Make note of wire color-codes to ensure proper installation during reassembly.

3. Remove the knobs from the VAR TIME/DIV control and the A AND B TIME/DIV switches (1/16" Allen wrench required). Be careful not to lose the plastic bushing behind the knobs.

4. Remove the X10 MAG and the UNCAL light lenses. Pry them away from the instrument front panel with a fingernail and pull straight out.

5. Remove the four Interface board mounting screws that are nearest the Sweep Timing circuit board.

6. Remove the board mounting screw and the hex rod from the Sweep Timing circuit board (3/16" wrench or nutdriver required).

7. Use a flat blade screwdriver and pry the Timing Board away from the Interface Board. Gently pull away the corner of the Interface Board near the B External Trigger Input connector and simultaneously lift up on the Timing Board near the rear to fully disengage connector pins from the Interface Board.

To reinstall the Timing Board reverse the order of the removal steps.

Power Transformer Replacement. If the power transformer becomes defective, contact your local TEKTRONIX Field Office or representative for a warranty replacement (see warranty note in the front of this manual). Be sure to replace only with a direct replacement TEKTRONIX transformer. After the transformer is replaced check the performance of the complete instrument. The transformer is removed as follows:

1. Unsolder the power cord from the Interface Board, the Regulating Range Selector Assembly, and the solder lug on the rear subpanel.

2. Remove the small blue panel from the rear panel of the instrument. It will be necessary to remove the cover from the Regulating Range Selector Assembly and the two feet from that side of the instrument.

3. Remove the actuating shaft from the POWER switch coupler. Exercise caution so as not to damage the switch coupler.

4. Remove the POWER switch mounting bracket from the Trigger Board.

5. Unsolder the transformer leads from the Interface Board and the solder lug on the rear subpanel. Note the wire color codes to facilitate correct reinstallation.

6. Remove the transformer leads from the Regulating Range Selector Assembly. It will be necessary to use a special pin removing tool available under TEKTRONIX part number 003-0707-00. It is only necessary to use this tool to remove the transformer leads from the Selector Assembly. The leads may be reinstalled by simply pushing them into place. Note wire color codes to facilitate correct reinstallation.

7. Remove the transformer bracket mounting hardware. This includes two screws on the Trigger Board, one screw on the Interface Board, two nuts on the U-channel (one on the transformer side and one on the CRT side), and two screws and nuts on the rear subpanel.

8. Thoroughly loosen the Trigger Board and remove the transformer assembly from the instrument.

9. Remove the thermal cutout and POWER switch from the old transformer and install on the new transformer. Note wire color codes to facilitate correct installation.

10. Install the new transformer assembly in the instrument reversing the order of the removal steps.

Recalibration After Repair

After any electrical component has been replaced, the calibration of that particular circuit should be checked, as well as the calibration of other closely related circuits. Since the power supply affects all circuits, calibration of the entire instrument should be checked if work has been done in the power supply or if the transformer has been replaced.

Instrument Repackaging

If the 465 is to be shipped for long distances by commercial means of transportation, it is recommended that the instrument be repackaged in the original manner for maximum protection. The original shipping carton can

be saved and used for this purpose. The Repackaging illustration in the Mechanical Parts Illustrations shows how to repackage the 465 and gives the part numbers for the repackaging components. New shipping cartons can be obtained from Tektronix, Inc. Contact your local TEKTRONIX Field Office or representative.

CALIBRATION

Calibration Interval

To assure instrument accuracy, check the calibration of the 465 every 1000 hours of operation, or every six months if used infrequently. Before complete calibration, thoroughly clean and inspect this instrument as outlined in the Maintenance section of the manual.

TEKTRONIX Field Service

Tektronix, Inc. provides complete instrument repair and recalibration at local Field Service Centers and the Factory Service Center. Contact your local TEKTRONIX Field Office or representative for further information.

Using This Procedure

Index. To aid in locating a step in the Performance Check or Calibration procedure, an index is given preceding Part I—Performance Check and Part III—Calibration procedure.

Performance Check. The performance of this instrument can be checked without removing the covers or making internal adjustments, by performing only Part I—Performance Check. This procedure does not check every facet of the instrument's calibration; rather it is concerned primarily with those portions of the instrument essential to measurement accuracy and correct operation.

Short-Form Calibration. A short-form calibration procedure is provided to the technician experienced with the 465 as guidelines for calibration of this instrument, in Part II—Short-Form Calibration.

Calibration Procedure. Completion of each step in Part III—Calibration procedure, ensures that this instrument meets the electrical specifications given in the front of this manual. Where possible, instrument performance is checked before an adjustment is made. For best overall instrument performance when performing a complete calibration procedure, make each adjustment to the exact setting even if the CHECK- is within the allowable tolerance.

Partial Procedures. A partial check or adjustment is often desirable after replacing components or to touch up the adjustment of a portion of the instrument between major recalibrations. To check or adjust only part of the instrument, set the controls as given under the nearest

Control Settings and use the Equipment Required list preceding the desired portion of the step. To prevent unnecessary recalibration of other parts of the instrument, readjust only if the tolerance given in the CHECK- part of the step is not met. If readjustment is necessary, also check the calibration of any steps listed in the INTERACTION- part of the step.

TEST EQUIPMENT REQUIRED

General

The following test equipment and accessories, or its equivalent, is required for complete calibration of the 465. Specifications given for the test equipment are the minimum necessary for accurate calibration. Therefore, some of the specifications listed here may differ from the actual performance capabilities of the test equipment. All test equipment is assumed to be correctly calibrated and operating within the listed specifications. Detailed operating instructions for the test equipment are not given in this procedure. Refer to the instruction manual for the test equipment if more information is needed.

If only a Performance Check procedure or a Calibration procedure is performed, not all of the listed test equipment will be required. Items used only for the Part III—Calibration procedure are indicated by footnote 1. The remaining pieces of equipment are items common to both a Performance Check procedure and a Calibration procedure.

Special Calibration Fixtures

Special TEKTRONIX calibration fixtures are used only where they facilitate instrument calibration. These special calibration fixtures are available from Tektronix, Inc. Order by part number through your local TEKTRONIX Field Office or representative.

Calibration Equipment Alternatives

All of the listed test equipment is required to completely check and calibrate this instrument. However, complete checking or calibration may not always be necessary or desirable. The user may be satisfied with checking only selected characteristics, thereby reducing the amount of test equipment actually required.

The Performance Check and Calibration procedure are based on the first item of equipment given as an example of

applicable equipment. When other equipment is substituted, control settings or calibration setup may need to be altered to meet the requirements of the substitute equipment. If the exact item of test equipment given as an example in the Test Equipment list is not available, first check the Specifications column carefully to see if any

other equipment is available which might suffice. Then check the Usage column to see what this item is used for. If used for a check or adjustment which is of little or no importance to your measurement requirements, the item and corresponding step(s) can be deleted.

TABLE 5-1
Test Equipment Required

| Description | Minimum Specifications | Usage | Examples of Applicable Test Equipment |
|---|--|--|---|
| 1. Variable Autotransformer ¹ | Capable of supplying 120 Volt-Amperes over a range of 103.5 to 126.5 volts. | Power Supply adjustment. | a. General Radio W10MT3W Variac Autotransformer. |
| 2. Precision DC Voltmeter ¹ | Range, zero to 100 volts; accuracy, within $\pm 0.05\%$. | Low voltage power supply check and adjustment. | a. Fluke Model 825A Differential DC Voltmeter. |
| 3. DC Voltmeter (VOM) ¹ | Range, zero to 2500 volts; accuracy, within 3%. | High voltage check and adjustment. | a. Triplet Model 630-NA. b. Simpson Model 262. |
| 4. Test Oscilloscope ¹ | Bandwidth, DC to 100 megahertz; minimum deflection factor, five millivolts/division; accuracy, within 3%. | Power supply checks, Z-Axis compensation; Vertical Gain adjustments; A Trigger Holdoff check; A & B Gate checks. | a. TEKTRONIX 454A Oscilloscope with two P6054 probes. |
| 5. Time-Mark Generator | Marker outputs, 5 nanoseconds to 0.5 second; marker accuracy, within 0.1%. | CRT geometry; Horizontal deflection system timing checks and adjustments. | a. TEKTRONIX 2901 Time-Mark Generator. b. TEKTRONIX 184 Time-Mark Generator. |
| 6. Standard Amplitude Calibrator | Amplitude accuracy, within 0.25%; signal amplitude, 5 millivolts to 50 volts; output signal, one-kilohertz square-wave and positive DC voltage. | Vertical deflection system checks. Trigger View deflection factor check. | a. TEKTRONIX calibration fixture Part Number 067-0502-01. |
| 7. Fast-Rise, High-Amplitude Pulse Generator | Risetime, 0.25 nanoseconds or less; repetition rate, 550 to 720 pulses/second; amplitude, variable from 20 millivolts to 10 volts. | Vertical deflection system checks. | a. TEKTRONIX Type 109 Pulse Generator. |
| 8. High-Frequency Constant Amplitude Signal Generator | Frequency, 65 megahertz to above 150 megahertz; reference frequency, three megahertz; output amplitude, variable from 0.5 volt to 4 volts; amplitude accuracy, within 1%. | Vertical system bandwidth checks. | a. TEKTRONIX calibration fixture 067-0532-01. |
| 9. Medium-Frequency Constant-Amplitude Signal Generator | Frequency, 350 kilohertz to 100 megahertz; reference frequency, 50 kilohertz; output amplitude, variable from 5 millivolts to 5 volts into 50 ohms or 10 volts unterminated; amplitude accuracy within 3%. | Vertical system bandwidth and trigger circuits operation checks. X-Y phasing check. | a. TEKTRONIX 191 Constant-Amplitude Signal Generator. b. General Radio 1211-C with 1263-C Amplitude Regulating Power Supply. |

TABLE 5-1 (cont)

| Description | Minimum Specifications | Usage | Examples of Applicable Test Equipment |
|---|--|---|---|
| 10. Low-Frequency Constant-Amplitude Signal Generator | Frequency, 10 hertz to 100 kilohertz; output amplitude, variable from 0.5 volt to 40 volts peak-to-peak; amplitude accuracy, within 3%. | Low Frequency triggering checks. | a. General Radio 1310-A Oscillator. |
| 11. Square-Wave Generator | Frequency, 10 hertz to one megahertz; risetime, one nanosecond or less from fast-rise output; output amplitude, about 120 volts unterminated or 12 volts into 50 ohms. | Vertical deflection system compensation checks. | a. TEKTRONIX Type 106 Square-Wave Generator. |
| 12. Signal Pickoff | Connectors, GR874 thru-signal connectors and BNC signal-pickoff connector. | Trigger system checks and adjustments. | a. TEKTRONIX Part Number 017-0061-00. |
| 13. Cable (two required) | Impedance, 50 ohms; type, RG-58/U; length, 42 inches; connectors, BNC. | Used for signal interconnection. | a. TEKTRONIX Part Number 012-0057-01. |
| 14. Cable | Impedance, 50 ohms; type, RG-58/U; length 18 inches; connectors, BNC. | Used for signal interconnection. | a. TEKTRONIX Part Number 012-0076-00. |
| 15. Cable | Impedance, 50 ohms; type, RG 213; electrical length, 5 nanoseconds; connectors, GR874. | Used for signal interconnection. | a. TEKTRONIX Part Number 017-0502-00. |
| 16. T-Connector | Connectors, BNC. | Used for signal interconnection. | a. TEKTRONIX Part Number 103-0030-00. |
| 17. Dual-Input Coupler (two required) | Connectors, BNC; matched signal transfer to each input. | Used for signal interconnection. | a. TEKTRONIX calibration fixture 067-0525-00. |
| 18. Input Normalizer | RC time constant, 20 picofarads times 1 megaohm. | Standardize input RC time constant. | a. TEKTRONIX Part Number 067-0538-00. |
| 19. Attenuator (two required) | Attenuation ratio, X10; connectors, BNC; impedance, 50 ohms. | Vertical amplifier compensation and trigger checks and adjustments. | a. TEKTRONIX Part Number 011-0059-01. |
| 20. Attenuator | Attenuation ratio, X2; connectors, BNC; impedance, 50 ohms. | Trigger checks and adjustments. | a. TEKTRONIX Part Number 011-0069-01. |
| 21. Adapter | BNC female connector to GR connector. | Used for signal interconnection. | a. TEKTRONIX Part Number 017-0063-00. |
| 22. Termination (two required) | Impedance, 50 ohms; accuracy, within 3%; connectors, BNC. | Bandwidth checks. | a. TEKTRONIX Part Number 011-0049-01. |
| 23. Screwdriver | Three-inch shaft; 3/32-inch bit. | Used throughout procedure to adjust variable resistors. | a. TEKTRONIX Part Number 003-0192-00. |
| 24. Low-Capacitance Screwdriver | 1 1/2-inch shaft. | Used throughout procedure to adjust variable capacitors. | a. TEKTRONIX Part Number 003-0000-00. |

Preliminary Control Settings

Preset the instrument controls to the settings given below when starting a Performance Check or a Calibration procedure.

Power Controls

Regulating Range Selector Medium
 Line Voltage Selector 115 V
 POWER ON

CRT Controls

INTENSITY Midrange
 FOCUS Midrange
 SCALE ILLUM Midrange
 BEAM FIND Off (button out)

**Vertical Controls
 (both Channels if applicable)**

VOLTS/DIV 5 mV
 VAR Calibrated detent
 POSITION Midrange

Input Coupling DC
 VERT MODE CH 1
 INVERT Off
 20 MHz BW (Pull) Off

**Triggering Controls
 (both A and B if applicable)**

LEVEL Fully clockwise
 SLOPE +
 COUPLING AC
 SOURCE NORM
 TRIG MODE AUTO

Sweep Controls

HORIZ DISPLAY A
 DELAY TIME POSITION Fully counterclockwise
 A TIME/DIV 1 ms
 B TIME/DIV 1 ms
 VAR TIME/DIV Calibrated detent
 X10 MAG Off (button out)
 POSITION Midrange
 FINE Midrange
 A TRIG HOLDOFF NORM

PART I - PERFORMANCE CHECK

Introduction

The following procedure is intended to be used for incoming inspection to determine the acceptability of newly purchased or recently recalibrated instruments. This procedure does not check every facet of the instrument's calibration; rather it is concerned primarily with those portions of the instrument which are essential to measurement accuracy and correct operation. Removing the instrument's dust cover is not necessary to perform this procedure. All checks are made from the front panel.

Index to Part I - Performance Check

VERTICAL SYSTEM CHECK

| | |
|--|-----------|
| 1. Check Beam Finder Operation | Page 5-6 |
| 2. Check Channel 1 and 2 Step Attenuator Balance | Page 5-6 |
| 3. Check Channel 1 and 2 Variable Volts/Division Balance | Page 5-6 |
| 4. Check Channel 2 Inverted Balance | Page 5-7 |
| 5. Check Channel 1 and 2 Position Range | Page 5-7 |
| 6. Check Channel 1 and 2 Gain | Page 5-7 |
| 7. Check Add Mode Operation | Page 5-7 |
| 8. Check Channel 1 and 2 Deflection Accuracy | Page 5-7 |
| 9. Check Channel 1 and 2 Variable Volts/Division Range | Page 5-8 |
| 10. Check Alternate Mode Operation | Page 5-8 |
| 11. Check Chop Mode Operation | Page 5-8 |
| 12. Check Low-Frequency Compensation | Page 5-8 |
| 13. Check Channel 1 and 2 Volts/Division Compensation | Page 5-9 |
| 14. Check Channel 2 High-Frequency Compensation | Page 5-9 |
| 15. Check Channel 1 High-Frequency Compensation | Page 5-9 |
| 16. Check Vertical Amplifier Bandwidth | Page 5-10 |
| 17. Check Cascaded Gain and Bandwidth | Page 5-10 |

TRIGGER SYSTEM CHECK

| | |
|-----------------------------------|-----------|
| 18. Check A Triggering | Page 5-11 |
| 19. Check B Triggering | Page 5-11 |
| 20. Check A Normal Mode Operation | Page 5-12 |
| 21. Check Single Sweep Operation | Page 5-12 |
| 22. Check Trigger View Operation | Page 5-12 |

HORIZONTAL SYSTEM CHECK

| | |
|--|-----------|
| 23. Check Differential Time Accuracy | Page 5-13 |
| 24. Check A Variable Time/Division Range | Page 5-13 |
| 25. Check A and B Timing Accuracy | Page 5-13 |
| 26. Check Delay Time Accuracy | Page 5-14 |
| 27. Check Delay Time Jitter | Page 5-14 |
| 28. Check Mixed Sweep Accuracy | Page 5-15 |
| 29. Check X Gains | Page 5-15 |
| 30. Check X-Y Phasing and Bandwidth | Page 5-15 |

Preliminary Procedure for Performance Check

NOTE

The performance of this instrument can be checked at any temperature within the 0°C to +40°C (+32°F to +104°F) temperature range unless stated otherwise.

1. Connect the 465 to a power source which meets the voltage and frequency requirements of this instrument.
2. Set the controls as given under Preliminary Control Settings.
3. Allow at least 20 minutes warmup before proceeding.

VERTICAL SYSTEM CHECK

Equipment Required

- | | |
|---|--|
| <p>1. Standard Amplitude Calibrator</p> <p>2. Square-Wave Generator (Type 106)</p> <p>3. High-Frequency Constant-Amplitude Signal Generator (067-0532-01)</p> <p>4. Medium-Frequency Constant-Amplitude Signal Generator (Type 191)</p> <p>5. Fast-Rise High-Amplitude Pulse Generator (Type 109)</p> | <p>6. 42-Inch 50 Ω BNC cable (two)</p> <p>7. GR-to-BNC Female Adapter</p> <p>8. 50 Ω BNC Termination</p> <p>9. 20 Pf RC Input Normalizer</p> <p>10. X10 BNC Attenuator</p> <p>11. Dual-Input Coupler</p> |
|---|--|

Control Settings

Preset instrument controls to the settings given under Preliminary Control Settings.

1. Check Beam Finder Operation

- a. Position the trace off screen with CH 1 POSITION control.
- b. Push the BEAM FIND button and hold it in.
- c. CHECK—That the trace is compressed and brought into the CRT viewing area.
- d. Release the BEAM FIND button.

2. Check Channel 1 and 2 Step Attenuator Balance

- a. Set both VOLTS/DIV switches to 20 mV and both Input Coupling switches to GND.
- b. Position the trace to the center horizontal line with the CH 1 POSITION control.
- c. CHECK—Rotate the CH 1 VOLTS/DIV switch from 20 mV to 5 mV. Trace should not move more than 0.2 division vertically between adjacent switch positions.
- d. Set the VERT MODE switch to CH 2.

e. Position the trace to the center horizontal line with the CH 2 POSITION control.

f. CHECK—Rotate the CH 2 VOLTS/DIV switch from 20 mV to 5 mV. Trace should not move more than 0.2 division vertically between adjacent switch positions.

3. Check Channel 1 and 2 Variable Volts/Division Balance

- a. Position the trace to the center horizontal line with the CH 2 POSITION control.
- b. Rotate the CH 2 VAR control through its range.
- c. CHECK—That the CH 2 UNCAL light comes on when the VAR control is out of the detent position.
- d. CHECK—CRT display for 1.0 division or less of vertical trace shift when rotating the CH 2 VAR control through its range.
- e. Set the VERT MODE switch to CH 1.
- f. Position the trace to the center horizontal line with the CH 1 POSITION control.
- g. Rotate the CH 1 VAR control through its range.

h. CHECK—That the CH 1 UNCAL light comes on when the VAR control is out of the detent position.

i. CHECK—CRT display for 1.0 division or less of vertical trace shift when rotating the CH 1 VAR control through its range.

j. Return both VAR controls to the detent position.

4. Check Channel 2 Inverted Balance

a. Set the VERT MODE switch to CH 2, and the CH 2 Input Coupling switch to GND.

b. Position the trace to the center horizontal line with the CH 2 POSITION control.

c. Push the INVERT switch.

d. CHECK—Trace does not vertically shift more than 2 divisions when switching from normal to inverted.

5. Check Channel 1 and 2 Position Range

a. Connect the Standard Amplitude Calibrator output to the CH 1 and CH 2 inputs via a 42-inch 50 Ω BNC cable and a dual input coupler.

b. Set both VOLTS/DIV switches to 20 mV and both Input Coupling switches to AC.

c. Adjust the Standard Amplitude Calibrator for a 500 mV output.

d. CHECK—That the top of the CRT display can be positioned down to 1/2-division above the center horizontal graticule line and the bottom of the display can be positioned up to 1/2-division below the center horizontal graticule line.

e. Set the VERT MODE switch to CH 1.

f. CHECK—That the top of the CRT display can be positioned down to 1/2-division above the center horizontal graticule line and the bottom of the display can be positioned up to 1/2-division below the center horizontal graticule line.

6. Check Channel 1 and 2 Gain

a. Set both VOLTS/DIV switches to 5 mV.

b. Set the Standard Amplitude Calibrator for a 20 mV square-wave output.

c. CHECK—CRT display for four divisions of deflection within 0.12 divisions.

d. Set the VERT MODE switch to CH 2.

e. CHECK—CRT display for four divisions of deflection within 0.12 divisions.

7. Check Add Mode Operation

a. Set both Input Coupling switches to DC.

b. Set the Standard Amplitude Calibrator for a 10 mV output.

c. Set the VERT MODE switch to ADD.

d. CHECK—CRT display for four divisions, ±0.12 division, in amplitude.

8. Check Channel 1 and 2 Deflection Accuracy

a. Set the VERT MODE switch to CH 1.

b. Set the CH 2 Input Coupling switch to GND.

c. CHECK—Using the CH 1 VOLTS/DIV switch and the Standard Amplitude Calibrator settings given in Table 5-2, check that the vertical deflection factor accuracy is within 3% in each position of the CH 1 VOLTS/DIV switch.

TABLE 5-2

Vertical Deflection Accuracy

| VOLTS/DIV Switch Setting | Standard Amplitude Calibrator Output | Vertical Deflection in Divisions | Maximum Error for 3% Accuracy |
|--------------------------|--------------------------------------|----------------------------------|-------------------------------|
| 5 m | 20 millivolts | 4 | Previously Checked |
| 10 m | 50 millivolts | 5 | ±0.15 division |
| 20 m | 0.1 volt | 5 | ±0.15 division |
| 50 m | 0.2 volt | 4 | ±0.12 division |
| 0.1 | 0.5 volt | 5 | ±0.15 division |
| 0.2 | 1 volt | 5 | ±0.15 division |
| 0.5 | 2 volts | 4 | ±0.12 division |
| 1 | 5 volts | 5 | ±0.15 division |
| 2 | 10 volts | 5 | ±0.15 division |
| 5 | 20 volts | 4 | ±0.12 division |

Calibration—465

- d. Set the VERT MODE switch to CH 2.
- e. Set the CH 1 Input Coupling switch to GND and the CH 2 Input Coupling switch to DC.
- f. CHECK—Using the CH 2 VOLTS/DIV switch and Standard Amplitude Calibrator settings given in Table 5-2, check that the vertical deflection factor accuracy is within 3% in each position of the CH 2 VOLTS/DIV switch.

9. Check Channel 1 and 2 Variable Volts/Division Range

- a. Set both VOLTS/DIV switches to 20 mV.
- b. Set the Standard Amplitude Calibrator for a 0.1 volt square-wave output.
- c. Rotate the CH 2 VAR control fully counterclockwise.
- d. CHECK—CRT display reduces to less than 2 divisions.
- e. Set the CH 1 Input Coupling switch to DC.
- f. Set the VERT MODE switch to CH 1.
- g. Rotate the CH 1 VAR control fully counterclockwise.
- h. CHECK—CRT display reduces to less than 2 divisions.
- i. Return both VAR controls to the detent position.
- j. Disconnect the test setup.

10. Check Alternate Mode Operation

- a. Set the VERT MODE switch to ALT, A LEVEL control fully clockwise, and both Input Coupling switches to GND.
- b. Position the traces 2 divisions apart.
- c. CHECK—That the sweeps alternate in all settings of the TIME/DIV switch except X-Y.

11. Check Chop Mode Operation

- a. Set TIME/DIV switches to 1 μ s, A SOURCE switch to NORM, A SLOPE switch to +, and VERT MODE switch to CHOP.
- b. Position the two traces about 4 divisions apart.

- c. Adjust the A LEVEL control for a stable display.

- d. CHECK—Duration of each cycle is about four divisions.

- e. CHECK—CRT display for complete blanking of switching transients between chopped segments.

12. Check Low Frequency Compensation

- a. Set the A TIME/DIV switch to 0.2 ms, the VERT MODE switch to CH 1, CH 1 Input Coupling switch to DC, both VOLTS/DIV switches to 5 mV, and the CH 2 Input Coupling switch to GND.

- b. Connect the fast-rise output of the Square-Wave Generator (Type 106) to the CH 1 and CH 2 inputs via a GR-to-BNC adapter, 42-inch 50 Ω BNC cable, X10 BNC attenuator, a 50 Ω BNC termination, and a dual input coupler.

- c. Adjust the Square-Wave Generator to maintain a five division display throughout this step.

- d. Adjust the Square-Wave Generator for a 1 kHz signal output.

- e. Adjust the A LEVEL control for a stable display.

- f. CHECK—CRT display for flat-top waveform with no more than 3% overshoot or roll-off on the leading edge.

- g. Set the A TIME/DIV switch to 20 μ s and adjust the Square-Wave Generator for a 10 kHz signal output.

- h. CHECK—CRT display for flat-top waveform with no more than 3% overshoot or roll-off on the leading edge.

- i. Set the A TIME/DIV switch to 2 μ s and adjust the Square-Wave Generator for a 100 kHz signal output.

- j. CHECK—CRT display for flat-top waveform with no more than 3% overshoot or roll-off on the leading edge.

13. Check Channel 1 and 2 Volts/Division Compensation

- a. Add a 20 pf Normalizer to the test setup between the 50 Ω BNC termination and the dual input coupler.
- b. Set both VOLTS/DIV switches to 5 mV.
- c. Move the test setup from the fast-rise output to the high-amplitude output of the Square-Wave Generator (Type 106).
- d. Adjust the Square-Wave Generator for a five-division display of a one-kilohertz signal. Add or remove attenuators, as necessary, to maintain a five-division display throughout this step.
- e. CHECK—CRT display for a flat-top waveform with no more than 3% overshoot or roll-off on the leading edge.
- f. Set the CH 1 VOLTS/DIV switch to 50 mV.
- g. CHECK—CRT display for a flat-top waveform with no more than 3% overshoot or roll-off on the leading edge.
- h. Set the CH 1 VOLTS/DIV switch to 0.5 V.
- i. CHECK—CRT display for a flat-top waveform with no more than 3% overshoot or roll-off on the leading edge.
- j. Set the CH 1 Input Coupling switch to GND, CH 2 Input Coupling switch to DC, and the VERT MODE switch to CH 2.
- k. CHECK—CRT display for a flat-top waveform with no more than 3% overshoot or roll-off on the leading edge.
- l. Set the CH 2 VOLTS/DIV switch to 50 mV.
- m. CHECK—CRT display for a flat-top waveform with no more than 3% overshoot or roll-off on the leading edge.
- n. Set the CH 2 VOLTS/DIV switch to 0.5 V.
- o. CHECK—CRT display for a flat-top waveform with no more than 3% overshoot or roll-off on the leading edge.
- p. Disconnect the test setup.

14. Check Channel 2 High-Frequency Compensation

- a. Set both VOLTS/DIV switches to 5 mV, the A TIME/DIV switch to 0.05 μ s, and the A SLOPE switch to +.
- b. Connect the Fast-Rise High-Amplitude Pulse Generator (Type 109) to the CH 2 input via a GR-to-BNC adapter, 42-inch 50 Ω BNC cable, two X10 BNC attenuators, and a 50 Ω BNC termination.
- c. Set the Pulse Generator polarity to + and the voltage range to 50 V.
- d. Adjust the Pulse Generator for five divisions of deflection. Remove or add attenuators as necessary to maintain a five division display throughout this step.
- e. CHECK—CRT display for risetime of 3.5 nanoseconds or less.
- f. CHECK—CRT display for flat-top waveform with 3% or less aberrations.
- g. Set the Pulse Generator polarity to – and the 465 A SLOPE switch to –.
- h. CHECK—CRT display for flat-bottom waveform with 5% or less aberrations.
- i. Set the A SLOPE switch to + and Pulse Generator polarity to +.
- j. Repeat the high-frequency compensation check procedure, steps 14-e through 14-i, for each setting of the CH 2 VOLTS/DIV switch from 10 mV to 5 V.

15. Check Channel 1 High-Frequency Compensation

- a. Set the VERT MODE switch to CH 1, the CH 1 Input Coupling switch to DC, and the A SLOPE switch to +.
- b. Move the test signal to the CH 1 input via a GR-to-BNC adapter, 42-inch 50 Ω BNC cable, two X10 BNC attenuators, and a 50 Ω BNC termination.
- c. Set the Pulse Generator polarity to +.

Calibration—465

d. Adjust the Pulse Generator for five divisions of deflection. Remove or add attenuators as necessary to maintain a five-division display throughout this step.

e. CHECK—CRT display for risetime of 3.5 nanoseconds or less.

f. CHECK—CRT display for flat-top waveform with 3% or less aberrations.

g. Set the Pulse Generator polarity to — and the 465 A SLOPE switch to —.

h. CHECK—CRT display for flat-bottom waveform with 5% or less aberrations.

i. Set the A SLOPE switch to + and the Pulse Generator polarity to +.

j. Repeat the high-frequency compensation check procedure, steps 15-e through 15-i, for each setting of the CH 1 VOLTS/DIV switch from 10 mV to 5 V.

k. Disconnect the test setup.

16. Check Vertical Amplifier Bandwidth

a. Set both VOLTS/DIV switches to 5 mV and the A TIME/DIV switch to 0.2 ms.

b. Connect the output of the High-Frequency Constant-Amplitude Signal Generator (067-0532-01) to the CH 1 input via a GR-to-BNC adapter, X10 BNC attenuator, and a 50 Ω BNC termination.

c. Adjust the High-Frequency signal generator output amplitude for a five-division display of a 3 megahertz reference signal.

d. Without changing the output amplitude, increase the output frequency of the High-Frequency signal generator until the display is reduced to 3.5 divisions.

e. CHECK—Output frequency of the signal generator must be at least 100 megahertz (0°C to +40°C).

f. Repeat this bandwidth check procedure, steps 16-c to 16-e, for settings of the CH 1 VOLTS/DIV switch from 10 mV to 2 V.

g. Move the test signal to CH 2.

h. Set the VERT MODE to CH 2.

i. Repeat the above bandwidth check procedure, steps 16-c to 16-e, for settings of the CH 2 VOLTS/DIV switch from 5 mV to 2 V.

j. Disconnect the test setup.

17. Check Cascaded Gain and Bandwidth

a. Set both Input Coupling switches to DC, both VOLTS/DIV switches to 5 mV, and the A TIME/DIV switch to 1 ms.

b. Connect the CH 1 OUT (on the rear panel) to the CH 2 input connector via a 42-inch 50 Ω BNC cable and a 50 Ω BNC termination.

c. Connect the Standard Amplitude Calibrator to the CH 1 input via a 42-inch 50 Ω BNC cable.

d. Adjust the Standard Amplitude Calibrator for a 5 mV output.

e. CHECK—CRT display for at least five divisions of deflection.

f. Remove the test setup from the CH 1 input.

g. Connect the output of the Medium-Frequency Constant-Amplitude Signal Generator (Type 191) to the CH 1 input via a GR-to-BNC adapter, 42-inch 50 Ω BNC cable, X10 BNC attenuator, and a 50 Ω BNC termination.

h. Adjust the Medium-Frequency signal generator for a five-division display of a 50 kilohertz reference signal.

i. Without changing the output amplitude of the signal generator, increase the output frequency until the display is reduced to 3.5 divisions.

j. CHECK—Output frequency of the signal generator must be at least 50 megahertz.

k. Disconnect the test setup.

TRIGGER SYSTEM CHECK

Equipment Required

- | | |
|--|--|
| 1. Medium-Frequency Constant-Amplitude Signal Generator (Type 191) | 6. 50 Ω Signal Pickoff Unit (Type CT-3) |
| 2. Standard Amplitude Calibrator | 7. X10 BNC Attenuator |
| 3. 50 Ω 5 Nanosecond GR Cable | 8. X2 BNC Attenuator |
| 4. 42-Inch 50 Ω BNC Cable | 9. 50 Ω BNC Termination (two) |
| 5. GR-to-BNC Female Adapter | 10. Dual-Input Coupler |

Control Settings

Preset instrument controls to the settings given under Preliminary Control Settings except as follows:

both TIME/DIV .05 μ s

18. Check A Triggering

a. Connect the output of the Medium-Frequency Constant-Amplitude Signal Generator (Type 191) to the A External Trigger Input via a 50 Ω GR cable, a 50 Ω Signal Pickoff Unit (Type CT-3) thru output, GR-to-BNC adapter, X10 BNC attenuator, X2 BNC attenuator, and a 50 Ω BNC termination.

b. Connect the 10% BNC output connector of the 50 Ω Signal Pickoff Unit (Type CT-3) to the CH 1 and CH 2 inputs via a 50 Ω BNC termination, and a dual input coupler.

c. Adjust the Medium-Frequency signal generator to maintain a 0.3 division display of a 50 kilohertz signal.

d. Rotate the A SLOPE switch between + and —.

e. CHECK—A stable display can be obtained on both the + and — slopes of the displayed waveform in all positions of the A COUPLING switch by adjusting the A LEVEL control.

f. Set the A SOURCE switch to CH 1.

g. Repeat steps 18-d and 18-e.

h. Set the VERT MODE switch to CH 2.

i. Repeat steps 18-d and 18-e.

j. Set the A SOURCE switch to EXT and the CH 2 VOLTS/DIV switch to 20 mV.

k. Adjust the Medium-Frequency signal generator for a five-division display of a 50 kilohertz signal.

l. CHECK—That a stable display can be obtained, by adjusting the A LEVEL control, in both the + and — slopes of the displayed waveform in the AC, HF REJ, and DC positions of the A COUPLING switch.

m. Remove the X2 BNC attenuator from the External Trigger signal test setup.

n. CHECK—That a stable display can be obtained, by adjusting the A LEVEL control, in both the + and — slopes of the displayed waveform in the LF REJ position of the A COUPLING switch.

o. Replace the X2 BNC attenuator and set the A SOURCE switch to EXT \div 10.

p. Remove the X10 BNC attenuator from the External Trigger signal test setup.

q. Repeat steps 18-l through 18-n.

r. Replace both the X10 and X2 BNC attenuators to the External Trigger test setup.

s. Set the A SOURCE switch to NORM.

19. Check B Triggering

a. Move the External Trigger test signal to the B External Trigger input.

b. Adjust the Medium-Frequency signal generator to maintain a 0.3 division display of a 50 kilohertz signal.

c. Rotate the B SLOPE switch between + and —.

Calibration—465

d. CHECK—A stable display can be obtained on both the + and – slopes of the displayed waveform in all positions of the B COUPLING switch by adjusting the LEVEL controls.

e. Set the B SOURCE switch to CH 2.

f. Repeat steps 19-c and 19-d.

g. Set the VERT MODE switch to CH 1.

h. Repeat steps 19-c and 19-d.

i. Set the B SOURCE switch to EXT, CH 1 VOLTS/DIV to 20 mV.

j. Adjust the Medium-Frequency signal generator for a five division display of a 50 kilohertz signal.

k. CHECK—That a stable display can be obtained, by adjusting the LEVEL controls, in both the + and – slopes of the displayed waveform in the AC, HF REJ, and DC positions of the B COUPLING switch.

l. Remove the X2 BNC attenuator from the External Trigger signal test setup.

m. CHECK—That a stable display can be obtained, by adjusting the LEVEL controls, in both the + and – slopes of the displayed waveforms in the LF REJ position of the B COUPLING switch.

20. Check A Normal Mode Operation

a. Set the HORIZ DISPLAY switch to A, the A COUPLING switch to AC, the A SOURCE switch to NORM, and the TRIG MODE switch to AUTO.

b. Adjust the Medium-Frequency signal generator for a 50 kilohertz signal.

c. Adjust the A LEVEL control for a triggered display.

d. Switch the TRIG MODE switch to NORM.

e. CHECK—For a stable display.

f. Remove the test signal from the CH 1 input.

g. CHECK—For no trace in the absence of an adequate trigger signal.

21. Check Single Sweep Operation

a. Set the A COUPLING switch to AC, and the TRIG MODE switch to AUTO.

b. Reconnect the test signal from the Medium-Frequency signal generator to the CH 1 input.

c. Adjust the A LEVEL control for a triggered display.

d. Remove the test signal from the CH 1 input.

e. Press the SINGL SWP button.

f. CHECK—READY light comes on when SINGL SWP button is pressed and remains on until the test signal is re-applied.

g. Reconnect the test signal to the CH 1 input.

h. CHECK—READY light is extinguished.

i. Press the SINGL SWP button.

j. CHECK—That a single-sweep display (one sweep only) is presented.

k. Disconnect the test setup.

22. Check Trigger View Operation

a. Set the CH 1 Input Coupling switch to DC, the CH 1 VOLTS/DIV switch to 10 mV, the VERT MODE switch to CH 1, the A COUPLING switch to DC, the A SOURCE switch to EXT, the A SLOPE switch to +, and the A LEVEL control to 0.

b. Connect the output of the Standard Amplitude Calibrator to the A External Trigger Input via a 42-inch 50 Ω BNC cable.

c. Adjust the Standard Amplitude Calibrator for a 200 mV square-wave output.

d. Push the TRIG VIEW button and hold it in.

e. CHECK—For 3.2 to 4.8 divisions of display.

f. Release the TRIG VIEW button.

g. Disconnect the test setup.

HORIZONTAL SYSTEM CHECK

Equipment Required

- | | |
|--|---|
| 1. Time-Mark Generator 2. Standard Amplitude Calibrator 3. Medium-Frequency Constant-Amplitude Signal Generator (Type 191) | 4. 42-Inch 50 Ω BNC Cable 5. 50 Ω BNC Termination 6. Dual-Input Coupler |
|--|---|

Control Settings

Preset instrument controls to the settings given under Preliminary Control Settings except as follows:

| | |
|---------------|--------------------|
| HORIZ DISPLAY | B DLY'D |
| A TIME/DIV | 1 ms |
| B TIME/DIV | 5 μs |
| B SOURCE | STARTS AFTER DELAY |

23. Check Differential Time Accuracy

- a. Connect 1 ms time marks to the CH 1 input from the Time Mark Generator (Type 2901) via a 42-inch 50 Ω BNC cable and a 50 Ω BNC termination.
- b. Set the DELAY TIME POSITION dial to position the tenth time marker to the beginning of the sweep.
- c. Note the reading on the DELAY TIME POSITION dial.
- d. Adjust the DELAY TIME POSITION dial so that the ninth time marker is at the beginning of the sweep.
- e. CHECK—DELAY TIME POSITION dial for a reading one division less, within 0.01 division from +15°C to +35°C; (one division less, within 0.03 division from -15°C to +55°C) than the reading noted in step 23-c.
- f. Rotate the DELAY TIME POSITION dial to position each successive time marker to the beginning of the sweep.
- g. CHECK—DELAY TIME POSITION dial for a reading of one division less, within 0.01 division from +15°C to +35°C (one division less, within 0.03 division from -15°C to +55°C) than the adjacent time marker.

24. Check Variable Time/Division Range

- a. Set the HORIZ DISPLAY to A and the A TIME/DIV switch to 2 ms.
- b. Select 5 ms time marks from the Time Mark Generator.

- c. CHECK—At least 1 time marker/division can be obtained by adjusting the VAR TIME/DIV control.
- d. CHECK—That the UNCAL light comes on when the VAR TIME/DIV control is out of the detent position.
- e. Return the VAR TIME/DIV control to the detent position.

25. Check A and B Timing Accuracy

- a. CHECK—Using the A TIME/DIV switch and the Time Mark Generator settings given in Table 5-3, check A sweep timing, within 0.2 division, over the first ten divisions of the display.

TABLE 5-3

A and B Timing Accuracy

| A and B TIME/DIV Switch Setting | Time-Mark Generator Output | CRT Display (Markers/ Division) |
|---------------------------------------|-------------------------------|---------------------------------------|
| .05 μs | 50 nanosecond | 1 |
| .1 μs | 0.1 microsecond | 1 |
| .2 μs | 0.1 microsecond | 2 |
| .5 μs | 0.5 microsecond | 1 |
| 1 μs | 1 microsecond | 1 |
| 2 μs | 1 microsecond | 2 |
| 5 μs | 5 microsecond | 1 |
| 10 μs | 10 microsecond | 1 |
| 20 μs | 10 microsecond | 2 |
| 50 μs | 50 microsecond | 1 |
| .1 ms | 0.1 millisecond | 1 |
| .2 ms | 0.1 millisecond | 2 |
| .5 ms | 0.5 millisecond | 1 |
| 1 ms | 1 millisecond | 1 |
| 2 ms | 1 millisecond | 2 |
| 5 ms | 5 millisecond | 1 |
| 10 ms | 10 millisecond | 1 |
| 20 ms | 10 millisecond | 2 |
| 50 ms | 50 millisecond | 1 |
| A SWEEP ONLY | | |
| .1 s | 0.1 second | 1 |
| .2 s | 0.1 second | 2 |
| .5 s | 0.5 second | 1 |

b. Set the HORIZ DISPLAY to B DLY'D.

NOTE

The sweep will start at the top of the third time marker at 1.00 and the nineteenth time marker at 9.00 for sweep rates which are multiples of 2 (e.g., 2 μs, 20 μs, 0.2 ms, etc.). If in doubt as to the correct setting of the DELAY TIME POSITION dial, set the HORIZ DISPLAY switch to A INTEN and check which time marker is intensified.

26. Check Delay Time Accuracy

a. Set the B SOURCE switch to STARTS AFTER DELAY, the A TIME/DIV switch to 0.2 μs, and the B TIME/DIV switch to 0.05 μs.

b. CHECK—Using the A TIME/DIV switch, B TIME/DIV switch, and the Time Mark Generator settings given in Table 5-4, check that the delayed sweep accuracy is within the given tolerance. First set the DELAY TIME POSITION dial to 1.00 and rotate the dial until the sweep starts at the top of the second time marker. Note the control setting and then set the dial to 9.00 and rotate slightly until the sweep starts at the top of the tenth time marker. DELAY TIME POSITION dial setting must be 8.00 divisions higher, ± 8 minor dial divisions.

27. Check Delay Time Jitter

a. Set the DELAY TIME POSITION dial to 1.00, the HORIZ DISPLAY switch to B DLY'D, the A TIME/DIV switch to 1 ms, and the B TIME/DIV switch to 1 μs.

b. Position the time marker near the center of the display area with the DELAY TIME POSITION dial.

c. CHECK—Jitter on the leading edge of the time marker does not exceed 0.2 division (0.5 division if operating the instrument on 50 Hz line voltage). Ignore the slow drift.

d. Turn the DELAY TIME POSITION dial to 9.00 and adjust it so the time marker is displayed near the center of the display area.

e. CHECK—Jitter on the leading edge of the time marker does not exceed 0.2 division (0.5 division if operating the instrument on 50 Hz line voltage). Disregard the slow drift.

TABLE 5-4
Delayed Sweep Accuracy

| A TIME/ DIV Switch Setting | B TIME/ DIV Switch Setting | Time- Mark Generator Output | Allowable Error for Given Accuracy |
|-------------------------------------|-------------------------------------|--------------------------------------|--|
| .2 μs | .05 μs | .1 microsecond | ±8 minor dial divisions |
| .5 μs | .05 μs | .5 microsecond | |
| 1 μs | .1 μs | 1 microsecond | |
| 2 μs | .1 μs | 1 microsecond | |
| 5 μs | .1 μs | 5 microsecond | |
| 10 μs | 1 μs | 10 microsecond | |
| 20 μs | 1 μs | 10 microsecond | |
| 50 μs | 1 μs | 50 microsecond | |
| .1 ms | 10 μs | .1 millisecond | |
| .2 ms | 10 μs | .1 millisecond | |
| .5 ms | 10 μs | .5 millisecond | |
| 1 ms | .1 ms | 1 millisecond | |
| 2 ms | .1 ms | 1 millisecond | |
| 5 ms | .1 ms | 5 millisecond | |
| 10 ms | 1 ms | 10 millisecond | |
| 20 ms | 1 ms | 10 millisecond | |
| 50 ms | 1 ms | 50 millisecond | |
| .1 s | 10 ms | .1 second | |
| .2 s | 10 ms | .1 second | |
| .5 s | 10 ms | .5 second | |

28. Check Mixed Sweep Accuracy

a. Set the A TIME/DIV switch to 1 ms, the B TIME/DIV switch to 0.5 ms, the HORIZ DISPLAY switch to A, the B SOURCE switch to STARTS AFTER DELAY, and the DELAY TIME POSITION dial fully clockwise.

b. Select 1 ms time-marks from the Time Mark Generator.

c. CHECK—Timing between the second and tenth time-markers. Note any timing error for use in step 28-e.

d. Set the HORIZ DISPLAY switch to MIX.

e. CHECK—Timing between second and tenth time-markers is within 0.16 division, \pm the A sweep error noted in step 28-c.

f. Disconnect the test setup.

29. Check X Gain

a. Set the A TIME/DIV switch to X-Y, the VERT MODE switch to CH 2, both VOLTS/DIV switches to 5 mV, and the CH 1 Input Coupling switch to DC.

b. Apply a 20 mV square-wave from the Standard Amplitude Calibrator to the CH 1 or X input through a 42-inch 50 Ω BNC cable.

c. CHECK—CRT display for 4 divisions of deflection, within 4%, between the two displayed dots.

d. Disconnect the test setup.

30. Check X-Y Phasing and Bandwidth

a. Set both VOLTS/DIV switches to 5 mV, and both Input Coupling switches to AC.

b. Connect the output of the Medium-Frequency Constant-Amplitude Signal Generator (Type 191) to the CH 1 and CH 2 inputs through a 42-inch 50 Ω BNC cable, 50 Ω BNC termination, and a dual input coupler.

c. Adjust the Medium-Frequency signal generator for an eight-division horizontal display of a 50 kilohertz signal.

d. Center the display vertically and horizontally with the CH 1 and CH 2 POSITION controls.

e. CHECK—CRT display for an opening at the center horizontal line of 0.4 division or less (see Fig. 5-1).

f. Remove the dual input coupler from the test setup.

g. Reconnect the test signal to the CH 1 input.

h. Adjust the signal generator for a 10-division horizontal display of a 50 kilohertz signal.

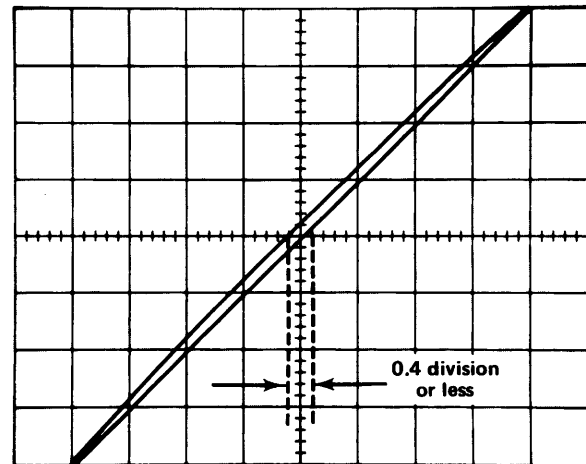

Fig. 5-1. Typical CRT display when checking X-Y phasing.

i. Adjust the signal generator frequency until the display is reduced to seven divisions.

j. CHECK—Output frequency of the signal generator is at least 4 megahertz.

k. Disconnect the test setup.

PART II - SHORT-FORM CALIBRATION

Introduction

The following procedure is intended to be used as guidelines for calibration of the 465 by experienced technicians familiar with the instrument. Only essential information is given. Test Equipment Required is the same as that given previously for the Part III - Calibration Procedure.

Preliminary Procedure for Short-Form Calibration

NOTE

This instrument should be adjusted at an ambient temperature of +25°C (± 5°C) for best overall accuracy.

1. Remove the dust cover from the 465.
2. Connect the 465 to the autotransformer and set the line voltage to 115 VAC.
3. Set the controls as given under Preliminary Control Settings (given prior to Part I - Performance Check). Allow at least 20 minutes warmup before proceeding.

NOTE

Titles for external controls of this instrument are capitalized in this procedure (e.g., INTENSITY). Internal adjustments are initial capitalized only (e.g., High Voltage).

POWER SUPPLIES AND DISPLAY CALIBRATION

1. Low Voltage Power Supplies

- a. ADJUST—+55 V supply, R1538, ± 0.5%, TP1536
- b. Check—+15 V supply, ±1.5%, TP1548
- c. Check—+5 V supply, ± 1.5%, TP1558
- d. Check— -8 V supply, ± 1.5%, TP1568
- e. Check—Ripple on all supplies except +55 V supply is 2 mV P-P maximum; +55 V supply ripple is 4 mV P-P maximum.
- f. Check—Regulation between 126.5 V and 103.5 V line.
- g. Check—Low line indicator comes on at 103.5 VAC.

2. High Voltage Power Supply

- a. Check— -2450 V supply is within ± 49 volts. Test Point is accessible through the hole in the high voltage cover.
- b. ADJUST—High Voltage, R1400, for -2450 volts, ±24.5 volts.

3. Adjust CRT Grid Bias

- a. TIME/DIV to X-Y
- b. Connect DC Voltmeter to TP1486 and adjust the INTENSITY for a reading of +20 V DC.
- c. ADJUST—CRT Grid Bias, R1480, for the dimmest dot that is still visible.

4. Check Display Controls

- a. SCALE ILLUM
- b. FOCUS
- c. INTENSITY

5. Z-Axis Compensation

- a. Connect a X10 probe from the Test Oscilloscope to TP1486.
- b. TIME/DIV to 0.05 μs.
- c. Adjust INTENSITY for a 15 volt P-P signal.
- d. ADJUST—C1471, for the best risetime and flat-top waveform.

6. Adjust Trace Alignment

- a. Connect time marks to CH 1 input.
- b. ADJUST—TRACE ROTATION to align trace with center graticule line.
- c. ADJUST—Y Axis Alignment, R1446, to align center time marker with the center vertical graticule line.
- d. Check for no more that 0.01 division curvature.
- e. ADJUST—Geometry, R1442, for no more than 0.1 division curvature of the time markers.
- f. Remove the time markers and check the trace at top and bottom graticule lines, no more than 0.1 division bowing or tilt.

VERTICAL SYSTEM CALIBRATION

7. Adjust Vertical Output Bias

a. Connect 100 MHz sine-wave into CH 1 from the High-Frequency Constant-Amplitude Signal Generator (067-0532-01).

b. ADJUST—Output Bias, R455, for maximum signal deflection.

c. This adjustment will affect vertical risetime, aberration, and position effect, and may be slightly misadjusted for optimum performance of the vertical system.

8. Adjust Vertical Output Centering

a. Connect DC Voltmeter between TP322 and TP324.

b. Adjust CH 1 POSITION for 0 volt reading on the meter.

c. ADJUST—Vertical Output Centering, R429, to position the trace to the center graticule line.

9. Check BEAM FIND Operation

10. Adjust CH 1 Step Attenuator Balance

a. ADJUST—CH 1 Step Atten Bal, R25, for no more than 0.2 division trace shift when switching between 5 mV, 10 mV, and 20 mV.

b. ADJUST—CH 1 Variable Balance, R120, for no more than 1 division trace shift when rotating the CH 1 VAR control through its range.

c. Check CH 1 UNCAL light.

11. Adjust CH 2 Step Attenuator Balance

a. ADJUST—CH 2 Step Atten Bal, R75, for no more than 0.2 division trace shift when switching between 5 mV, 10 mV, and 20 mV.

b. ADJUST—CH 2 Variable Balance, R220, for no more than 1 division trace shift when rotating the CH 2 VAR control through its range.

c. Check CH 2 UNCAL light.

12. Check Probe Indicator Light

a. Connect a X10 probe to CH 1 input.

b. Check that the left light goes out and the right light comes on.

c. Repeat procedure for CH 2.

13. Check CH 1 and 2 INPUT COUPLING switch

14. Adjust CH 1 and 2 Position Centering

a. VOLTS/DIV switches to 20 mV.

INPUT COUPLING to AC

b. Connect a 500 mV signal from the Standard Amplitude Calibrator to the CH 1 input.

c. ADJUST—CH 1 Position Centering, R115, so the top and bottom of the display can be positioned past the center horizontal line.

d. INTERACTION—R115 interacts with R120. Repeat steps 10 and 14 for minimum trace shift.

e. Repeat the above procedure for CH 2, adjusting R215.

f. INTERACTION—R215 interacts with R220. Repeat steps 11 and 14 for minimum trace shift.

15. Check CH 2 Invert Balance and Operation

16. Adjust CH 1 Gain

a. CH 1 VOLTS/DIV to 5 mV.

b. Connect 20 mV signal from Standard Amplitude Calibrator to CH 1 input.

c. ADJUST—CH 1 Gain, R118, for 200 mV push-pull signal between TP322 and TP324.

d. ADJUST—Vertical Output Gain, R400, for exactly 4 divisions of deflection.

e. Check all attenuator ranges for proper deflection, within 3%.

f. Check Variable Range: CH 1 VAR control must reduce a 5 division signal to less than 2 divisions.

17. Adjust CH 2 Gain

- a. CH 2 VOLTS/DIV to 5 mV
- b. Connect 20 mV signal from Standard Amplitude Calibrator to CH 2 input.
- c. ADJUST—CH 2 Gain, R218, for exactly 4 divisions of deflection.
- d. Check all attenuator ranges for proper deflection, within 3%.
- e. Check Variable Range: CH 2 VAR control must reduce a 5 division signal to less than 2 divisions.

18. Check ADD Operation

- a. Both VOLTS/DIV to 5 mV
Both INPUT COUPLING switches to DC
- b. Connect 10 mV from Standard Amplitude Calibrator to both CH inputs.
- c. Set VERT MODE to ADD.
- d. CHECK—If CH 1 and CH 2 Gains were adjusted, check for 4 divisions of deflection, within 1% (within 3% if CH 1 and CH 2 Gains were not adjusted).

19. Check Compression and Expansion

- a. With 2 division signal, position to top and bottom of graticule.
- b. Check for no more than 0.1 division of compression or expansion.

20. Check Vertical ALternate Operation On All Sweep Speeds

21. Check Vertical CHOP Operation

- a. TIME/DIV to 1 μ s
VERT MODE to CHOP
- b. Check for blanking of transients at normal INTENSITY level.
- c. Check duration of each cycle is about 4 divisions.

22. Adjust Vertical Output Low-Frequency Compensation

- a. Connect the fast-rise output of the Square-Wave Generator (Type 106) to CH 1 input.
- b. ADJUST—R424, R433, R434 for best flat-top waveform using 1 kHz, 10 kHz, and 100 kHz signals.

23. Adjust VOLTS/DIV Compensation

- a. Adjust CH 1 VOLTS/DIV Compensation for no more than 2% aberrations. Use 20 picofarad Normalizer and a 5 division signal.

| | |
|-------|----------|
| 5 mV | C1 |
| 10 mV | Check |
| 20 mV | Check |
| 50 mV | C12, C13 |
| .1 V | Check |
| .2 V | Check |
| .5 V | C10, C11 |
| 1 V | Check |
| 2 V | Check |
| 5 V | Check |

- b. Repeat procedure for CH 2.

24. Adjust Vertical Output High-Frequency Compensation

- a. VOLTS/DIV to 5 mV
A TIME/DIV to 0.05 μ s
- b. Adjust for a 5 division display from the Fast-Rise High-Amplitude Pulse Generator (Type 109) to CH 2 input.
- c. ADJUST—C77, C83, C205, R205, C249, R249, C403, C442, R442, C443, for no more than 3% aberrations and a 3.5 nanosecond, or less, risetime.
- d. Check negative step aberrations, within 5%.
- e. CH 2 VOLTS/DIV to 10 mV
- f. ADJUST—R97, C97, for aberrations within 3% and 3.5 nanosecond, or less, risetime.
- g. Check negative step aberrations, within 5%.
- h. CH 2 VOLTS/DIV to 20 mV

i. ADJUST—R98, C98, for aberrations within 3% and 3.5 nanosecond, or less, risetime.

j. Check negative step aberrations, within 5%.

k. Check remaining settings of CH 2 VOLTS/DIV switch for: Positive step aberrations within 3%; risetime of 3.5 nanoseconds, or less; negative step aberrations within 5%.

l. Check position effect: Positive step aberrations within 5%, negative step aberrations within 7%.

25. Adjust CH 1 High-Frequency Compensation

a. Repeat step 24-c with adjustments C27, C33, C105, R105, C122, R122, C149, and R149.

b. Adjust R47, C47 for step 24-f.

c. Adjust R48, C48 for step 24-i.

26. Check Vertical Amplifier Bandwidth

a. Use the High-Frequency Constant-Amplitude Signal Generator (067-0532-01): 5 division display of 3 MHz reference signal.

b. From 5 mV to 5 V settings of both VOLTS/DIV switches, check frequency is at least 100 MHz (0°C to +40°C) when display is reduced to 3.5 division.

27. Check Cascaded Bandwidth and Sensitivity

a. Connect CH 1 OUT to CH 2 input through a terminated cable.

b. Check that the sensitivity is at least 1 mV/division.

c. Check Bandwidth is at least 50 MHz.

28. Check Vertical Channel Isolation and CMRR

a. Channel isolation: at least 100:1 at 25 MHz.

b. CMRR: at least 10:1 at 20 MHz for signals of 6 divisions or less.

29. Check Bandwidth Limit Operation

a. Connect 6 division display of a 50 kHz signal to CH 1 input.

b. Check frequency is 20 MHz, within 4 MHz, when display is reduced to 4.2 divisions.

TRIGGER SYSTEM CALIBRATION

30. Adjust A and B Trigger Sensitivity

a. VOLTS/DIV to 10 mV

both TIME/DIV to 0.05 μ s

A SOURCE to EXT

A COUPLING to AC

A SLOPE to +

b. Connect the output of the Medium-Frequency Constant-Amplitude Signal Generator (Type 191) to the A and B External Trigger Inputs via a 50 Ω 5 ns GR cable, 50 Ω Signal Pickoff thru output, GR-to-BNC adapter, X10 attenuator, 50 Ω termination, and a dual input coupler.

c. Connect the 10% BNC output connector of the Signal Pickoff Unit to the CH 1 and CH 2 inputs via a terminated dual input coupler.

d. ADJUST—A and B Sensitivity, R655, R555, to just obtain a stable display with a 0.25 division display of 25 MHz signal.

31. Adjust LEVEL and SLOPE Centering

a. Position 0.3 division display of 50 kHz signal to center vertical graticule line.

b. ADJUST—A Level Center, R635, for triggered display.

c. ADJUST—A Slope Center, R645, so trigger point is the same when switching from + to - slope.

d. ADJUST—B Level Center, R535, for triggered display.

Calibration—465

e. ADJUST—B Slope Center, R545, so trigger point is the same when switching from + to – slope.

32. Adjust A Trigger DC Levels

- a. A COUPLING to DC
A SOURCE to NORM
A LEVEL to 0

b. 0.3 division display centered vertically on the CRT graticule.

c. ADJUST—Normal Trigger DC Level, R340, to obtain stable display in + and – slopes.

- d. A SOURCE to CH 1

e. ADJUST—CH 1 Trigger DC Level, R155, to obtain stable display in + and – slopes.

- f. VERT MODE to CH 2
A SOURCE to CH 2

g. ADJUST—CH 2 Trigger DC Level, R255, to obtain stable display in + and – slopes.

33. Check B Trigger DC Levels

34. Check Triggering

- a. High-frequency triggering

| Internal | 25 MHz | 100 MHz |
|----------|---------|---------|
| AC | 0.3 div | 1.5 div |
| LF REJ | 0.3 div | 1.5 div |
| DC | 0.3 div | 1.5 div |

External

| | | |
|--------|--------|--------|
| AC | 50 mV | 150 mV |
| LF REJ | 100 mV | 300 mV |
| DC | 50 mV | 150 mV |

Multiply by 10 for EXT ÷ 10 sensitivity.

b. HF REJ—Triggers on 0.3 division at 50 kHz; will not trigger at 350 kHz.

c. LF REJ—Triggers on 0.3 division at 50 kHz; will not trigger on 60 Hz.

- d. Check single sweep operation and READY light.

- e. Check A NORM triggering.

- f. Check LINE triggering.

- g. Check AUTO recovery time.

35. Check External LEVEL Range

- a. EXT: at least + and – 2 V for both A and B.
- b. EXT ÷ 10: at least + and – 20 V for A only.

36. Adjust TRIG VIEW Centering

a. ADJUST—Trigger View Centering R675, so trace is at center horizontal line, within 1 division.

b. Connect 200 mV square-wave from Standard Amplitude Calibrator to A External Trigger Input.

c. Check for 3.2 to 4.8 divisions of display with TRIG VIEW in.

HORIZONTAL SYSTEM CALIBRATION

37. Adjust Sweep Start and A Sweep Calibration

- a. B SOURCE to STARTS AFTER DELAY

HORIZ DISPLAY to A INTEN

A TIME/DIV to 1 ms

B TIME/DIV to 5 μ s

DELAY TIME POSITION to 1.00

- b. Use 1 ms time markers.

c. ADJUST—R1115, to intensify start of the 2nd time marker.

d. DELAY TIME POSITION to 9.00.

e. ADJUST—R1145 to intensify start of 10th time marker.

f. HORIZ DISPLAY to B DLY'D

g. ADJUST—R1145, so 10th time marker starts at the sweep start.

h. DELAY TIME POSITION to 1.00.

i. ADJUST—R1115, so 2nd time marker starts at the sweep start.

j. INTERACTION—There is interaction between R1115 and R1145. Readjust both to minimize interaction.

k. HORIZ DISPLAY to A.

l. ADJUST—R1237 for one time marker/division.

38. Adjust B Sweep Calibration

- a. B TIME/DIV to 1 ms

HORIZ DISPLAY to B DLY'D

b. ADJUST—R1175, for one time marker/division.

39. Check Differential Time Accuracy

a. Accuracy within 0.01 division between adjacent time markers from +15°C to +35°C.

b. Accuracy within 0.03 division from -15°C to +55°C.

40. Adjust Horizontal Gain

- a. HORIZ DISPLAY to A

both TIME/DIV to 1 ms

b. Use 1 ms time marks.

c. ADJUST—X1 Gain, R1237, for exactly 1 time marker/division.

d. Use 0.1 ms time marks.

e. X10 MAG—in.

f. ADJUST—X10 Gain, R1238, for exactly 1 time marker/division.

41. Check Sweep Linearity

42. Adjust Magnifier Registration

- a. Use 5 ms time marks.

b. Position the middle magnified time marker to the center vertical graticule line.

c. Turn the X10 MAG off.

d. CHECK—Center time marker should align with the center vertical graticule line, within 0.2 division.

e. ADJUST—Magnifier Registration R1225 to align the center time marker with the center vertical graticule line.

43. Check A Sweep Length

11 divisions, \pm 0.5 division.

44. Check VAR TIME/DIV Range

- a. A TIME/DIV to 2 ms

HORIZ DISPLAY to A

b. Use 5 ms time marks.

c. Check for 1 time marker/division by rotating the VAR TIME/DIV control.

d. Check UNCAL light.

45. Check Horizontal POSITION Control Range

46. Adjust High Speed Timing

- a. B SOURCE to STARTS AFTER DELAY

A TIME/DIV to $0.5 \mu\text{s}$

B TIME/DIV to $0.05 \mu\text{s}$

HORIZ DISPLAY to A INTEN

- b. Use $0.5 \mu\text{s}$ time marks.

- c. ADJUST—C1137, for 1 time marker/division.

- d. HORIZ DISPLAY to B DLY'D

DELAY TIME POSITION to 1.50

- e. With horizontal POSITION have time marker cross the center vertical graticule line.

- f. DELAY TIME POSITION to 8.50.

- g. ADJUST—C1137, so time marker crosses the center vertical graticule line.

- h. Repeat procedure for optimum timing.

- i. HORIZ DISPLAY to B DLY'D

B SOURCE to NORM

A TIME/DIV to $1 \mu\text{s}$

B TIME/DIV to $0.5 \mu\text{s}$

DELAY TIME POSITION fully counterclockwise

- j. ADJUST—C1167, for 1 time marker/division.

47. Check A and B Timing Accuracy

Within 0.2 division over first 10 divisions of display.

48. Adjust High Speed Magnified Timing

- a. X10 MAG—on

A TIME/DIV to $0.05 \mu\text{s}$

- b. Use 10 nanosecond sinewave.

- c. ADJUST—Magnified Timing, C1261, C1281, for exactly one cycle/2 divisions. Disregard first and last 10 divisions of sweep length.

49. Check A and B Magnified Timing Accuracy

- a. Accuracy within 0.3 division.

- b. Exclude the following portions of the sweep:

at 5 ns: Exclude first and last 10 divisions

at 10 ns: Exclude first and last 5 divisions

at 20 ns: Exclude first and last 2.5 divisions

50. Check Delay Time Accuracy

Within 8 minor dial divisions.

51. Check Delay Time Jitter

- a. A TIME/DIV to 1 ms

B TIME/DIV to $1 \mu\text{s}$

HORIZ DISPLAY to B DLY'D

- b. Use 1 ms time marks.

- c. CHECK—Jitter on the leading edge of the time marker does not exceed 0.2 division (0.5 division if operating the instrument on 50 Hz line voltage). Ignore the slow drift.

52. Check MIX Sweep Accuracy

- a. Use 1 ms time marks.

- b. Check for proper timing within 0.16 division \pm the A sweep error.

53. Adjust X Gain

- a. A TIME/DIV to X-Y

both VOLTS/DIV to 5 mV

b. Apply 20 mV square wave from Standard Amplitude Calibrator to CH 1 or X input.

c. ADJUST—X Gain, R1215, for 4 divisions of deflection between the dots, within 4%.

54. Check X-Y Phasing and Bandwidth

a. VERT MODE to CH 2

b. Connect an 8 division display of 50 kHz signal from the Medium-Frequency Constant-Amplitude Signal Generator (Type 191) to the CH 1 and 2 inputs.

c. Check X-Y phase shift is no more than 0.4 division.

d. Check bandwidth is at least 4 MHz.

55. Check B Ends A Operation

56. Check A Trigger Holdoff

Increases holdoff by at least a factor of 10.

57. Check A and B Gates

a. A Gate: 5.5 V, within 0.5 V.

b. B Gate: 5.5 V, within 0.5 V.

58. Check EXT Z-AXIS Operation

a. Connect 5 V square wave to External Trigger Input and EXT Z-AXIS input.

b. Check for noticeable intensity modulation.

PART III - CALIBRATION

Introduction

The following procedure returns the 465 to correct calibration. All limits and tolerances given in this procedure are calibration guides and should not be interpreted as instrument specifications except as specified in the Specifications section of this manual. Where possible, instrument performance is checked before an adjustment is made. For best overall instrument performance when performing a complete calibration procedure, make each adjustment to the exact setting even if the CHECK— is within the allowable tolerance.

Index to Part III - Calibration

POWER SUPPLY CALIBRATION

- 1. Check Power Supply DC Levels and Ripple Page 5-27
- 2. Adjust High Voltage Supply Page 5-27

DISPLAY and Z-AXIS CALIBRATION

- 3. Adjust CRT Grid Bias Page 5-28
- 4. Check Display Controls Page 5-28
- 5. Adjust Trace Alignment Page 5-29
- 6. Adjust Y Axis Alignment Page 5-29
- 7. Adjust Geometry Page 5-29
- 8. Adjust Z-Axis Compensation Page 5-29

VERTICAL SYSTEM CALIBRATION

- 9. Adjust Vertical Output Amplifier Bias Page 5-30
- 10. Adjust Vertical Output Centering and Check BEAM FIND Page 5-30
- 11. Adjust Channel 1 Step Attenuator Balance Page 5-31
- 12. Adjust Channel 1 Variable Volts/Division Balance Page 5-31

- 13. Check Probe Indicator Lights Page 5-32
- 14. Check Channel 1 and 2 INPUT COUPLING Switches Page 5-32
- 15. Adjust Channel 1 Position Centering Page 5-32
- 16. Adjust Channel 2 Step Attenuator Balance Page 5-32
- 17. Adjust Channel 2 Variable Volts/Division Balance Page 5-33
- 18. Adjust Channel 2 Position Range Page 5-33
- 19. Check Channel 2 INVERT Balance Page 5-33
- 20. Adjust Channel 1 Gain Page 5-33
- 21. Adjust Channel 2 Gain Page 5-34
- 22. Check Channel 1 and 2 Variable Volts/Division Range Page 5-35
- 23. Check Vertical ADD Mode Operation Page 5-35
- 24. Check Compression and Expansion Page 5-35
- 25. Check Vertical ALT Mode Operation Page 5-35
- 26. Check Vertical CHOP Mode Operation Page 5-36
- 27. Adjust Vertical Output Low-Frequency Compensation Page 5-36
- 28. Adjust Channel 1 VOLTS/DIV Compensation Page 5-36
- 29. Adjust Channel 2 VOLTS/DIV Compensation Page 5-37

| | | | |
|--|-----------|---|-----------|
| 30. Adjust Channel 2 and Vertical Output High-Frequency Compensation | Page 5-38 | 48. Check B External 25 Megahertz Triggering | Page 5-46 |
| 31. Check Channel 2 Position Effect | Page 5-39 | 49. Check A and B External 100 Megahertz Triggering | Page 5-47 |
| 32. Adjust Channel 1 High-Frequency Compensation | Page 5-39 | 50. Check B Internal 100 Megahertz Triggering | Page 5-47 |
| 33. Check Channel 1 Position Effect | Page 5-41 | 51. Check A Internal 100 Megahertz Triggering | Page 5-48 |
| 34. Check Vertical Amplifier Bandwidth | Page 5-41 | 52. Check A and B HF REJ Triggering | Page 5-48 |
| 35. Check Cascaded Gain and Bandwidth | Page 5-41 | 53. Check B 60 Hertz and LF REJ Triggering | Page 5-49 |
| 36. Check Vertical Channel Isolation | Page 5-42 | 54. Check A 60 Hertz and LF REJ Triggering | Page 5-49 |
| 37. Check Common Mode Rejection Ratio | Page 5-42 | 55. Check A LEVEL Control External Range | Page 5-50 |
| 38. Check Bandwidth Limit Operation | Page 5-42 | 56. Check B LEVEL Control External Range | Page 5-50 |
| TRIGGER SYSTEM CALIBRATION | | | |
| 39. Adjust A Trigger Sensitivity | Page 5-43 | 57. Check Single Sweep Operation | Page 5-51 |
| 40. Adjust B Trigger Sensitivity | Page 5-44 | 58. Check A Normal Mode Operation | Page 5-51 |
| 41. Adjust B Trigger Slope and Level Centering | Page 5-44 | 59. Check LINE Triggering | Page 5-51 |
| 42. Adjust A Trigger Slope and Level Centering | Page 5-44 | 60. Check Automatic Recovery Time | Page 5-51 |
| 43. Adjust A Trigger DC Levels | Page 5-44 | 61. Adjust Trigger View Centering | Page 5-52 |
| 44. Check B Trigger DC Levels | Page 5-45 | 62. Check Trigger View Deflection Factor | Page 5-52 |
| 45. Check B Internal 25 Megahertz Triggering | Page 5-45 | HORIZONTAL SYSTEM CALIBRATION | |
| 46. Check A Internal 25 Megahertz Triggering | Page 5-46 | 63. Adjust Sweep Start and A Sweep Calibration | Page 5-53 |
| 47. Check A External 25 Megahertz Triggering | Page 5-46 | 64. Check Differential Time Accuracy | Page 5-53 |

Calibration—465

| | | | |
|---|-----------|--|-----------|
| 65. Adjust Horizontal Amplifier Gain | Page 5-54 | 82. Check B ENDS A Operation | Page 5-59 |
| 66. Check Sweep Linearity | Page 5-54 | 83. Check A TRIG HOLDOFF | Page 5-59 |
| 67. Adjust Magnifier Registration | Page 5-54 | | |
| 68. Adjust B Sweep Calibration | Page 5-55 | CALIBRATOR, GATES, & EXT Z-AXIS CALIBRATION | |
| 69. Check Sweep Length | Page 5-55 | 84. Adjust CALIBRATOR Output | Page 5-60 |
| 70. Check VAR TIME/DIV Range | Page 5-55 | 85. Check A and B + GATE | Page 5-60 |
| 71. Check Horizontal POSITION Control Range | Page 5-55 | 86. Check EXT Z-AXIS Operation | Page 5-60 |
| 72. Adjust A TIME/DIV High Speed Timing | Page 5-55 | | |
| 73. Adjust B TIME/DIV High Speed Timing | Page 5-56 | | |
| 74. Check A and B TIME/DIV Accuracy | Page 5-56 | | |
| 75. Adjust High Speed Magnified Timing | Page 5-56 | | |
| 76. Check A and B Magnified Timing Accuracy | Page 5-57 | | |
| 77. Check Delay Time Accuracy | Page 5-57 | | |
| 78. Check Delay Time Jitter | Page 5-58 | | |
| 79. Check Mixed Sweep Accuracy | Page 5-58 | | |
| 80. Adjust X Gain | Page 5-58 | | |
| 81. Check X-Y Phasing and Bandwidth | Page 5-58 | | |

Preliminary Procedure for Calibration

NOTE

This instrument should be adjusted at an ambient temperature of +25°C (± 5°C) for best overall accuracy.

1. Remove the dust cover from the 465 as outlined in the Disassembly Instructions in the Maintenance section of the manual.
2. Connect the autotransformer to a suitable power source.
3. Connect the 465 to the autotransformer output.
4. Set the autotransformer output voltage to the center of the voltage range selected by the Line Voltage Selector.
5. Set the controls as given under Preliminary Control Settings (given prior to Part I - Performance Check). Allow at least 20 minutes warmup before proceeding.

NOTE

Titles for external controls of this instrument are capitalized in this procedure (e.g., INTENSITY). Internal adjustments are initial capitalized only (e.g., CRT Grid Bias).

POWER SUPPLY CALIBRATION

Equipment Required

- | | |
|--|---|
| <ol style="list-style-type: none"> 1. Precision DC Voltmeter 2. DC Voltmeter 3. Test Oscilloscope | <ol style="list-style-type: none"> 4. Autotransformer 5. Three-inch Screwdriver |
|--|---|

Control Settings

Preset instrument controls to the settings given under Preliminary Control Settings.

1. Check Power Supply DC Levels and Ripple

a. Connect the Precision DC Voltmeter between test point (TP) 1536 and GND (negative meter lead to ground) on the Interface board. See Fig. 5-2.

b. CHECK—Meter reading of +55 volts within 0.5% (± 27.5 mV).

c. ADJUST—+55 Volt Supply adjustment R1538 (see Fig. 5-2) for a meter reading of +55 volts within 0.1% (0.05 mV).

d. Using the precision DC Voltmeter, measure the DC level of the power supplies given in Table 5-5. Observe proper meter polarity. See Fig. 5-2 for test point locations.

e. Using the Test Oscilloscope, check for correct ripple as given in Table 5-5, while varying the autotransformer between 103.5 VAC to 126.5 VAC.

f. CHECK—For low line indicator to come on when the autotransformer is at 103 volts.

g. Return the line voltage to 115 volts.

TABLE 5-5

Power Supply Tolerance and Ripple

| Power Supply | Test Point | Tolerance | Typical Ripple (peak-to-peak) |
|--------------|------------|-------------|-------------------------------|
| +55 volt | TP1536 | $\pm 0.5\%$ | 4 mV |
| +15 volt | TP1548 | $\pm 1.5\%$ | 2 mV |
| +5 volt | TP1558 | $\pm 1.5\%$ | 2 mV |
| -8 volt | TP1568 | $\pm 1.5\%$ | 2 mV |

2. Adjust High Voltage Supply

a. Connect the DC Voltmeter between -2450 volt test point and ground (positive meter lead to ground). -2450 test point is accessible through the hole in the high voltage cover. (See Fig. 5-3.)

b. CHECK—Meter for a reading of -2450 volts ± 49 volts.

c. ADJUST—High Voltage adjustment R1400 (see Fig. 5-3) for a meter reading of -2450 volts (± 24.5 volts).

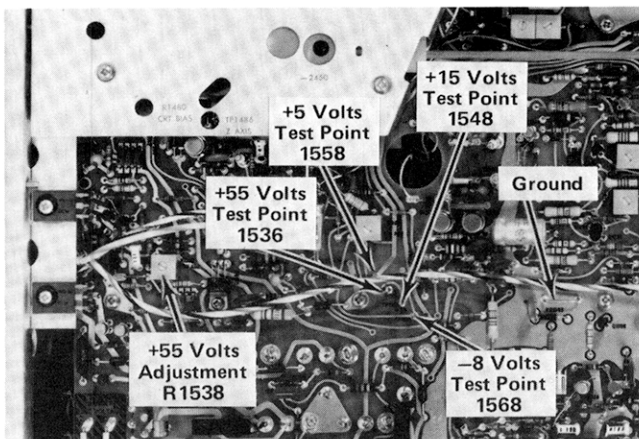

Fig. 5-2. Low-voltage power supply test points and adjustment locations.

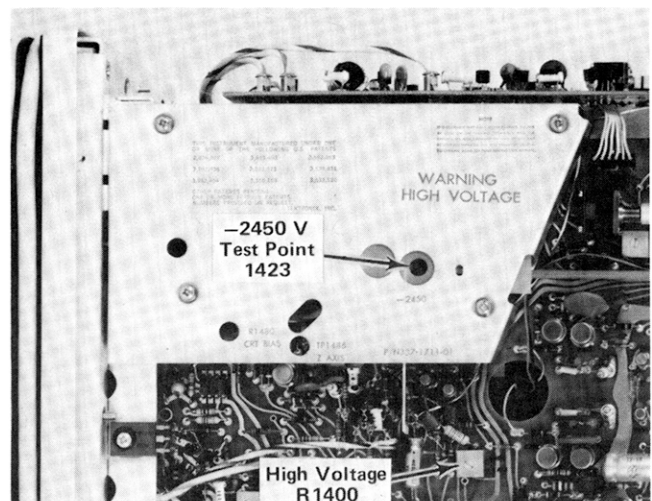

Fig. 5-3. High-voltage test point and adjustment locations.

DISPLAY & Z-AXIS CALIBRATION

Equipment Required

- | | |
|--|---|
| <ol style="list-style-type: none"> 1. DC Voltmeter 2. Test Oscilloscope 3. Time Mark Generator 4. 50 Ω BNC Cable | <ol style="list-style-type: none"> 5. 50Ω BNC Termination 6. X10 Probe 7. Three-inch Screwdriver 8. Low Capacitance Screwdriver |
|--|---|

Control Settings

Preset instrument controls to the settings given under Preliminary Control Settings except as follows:

| | |
|---------------------|------------------------|
| A TIME/DIV | X-Y |
| INTENSITY | Fully Counterclockwise |
| CH 1 INPUT COUPLING | GND |

3. Adjust CRT Grid Bias

a. Connect the DC Voltmeter between TP1486 which is accessible through a hole in the high voltage cover, and ground. (Negative meter lead to ground.) See Fig. 5-4.

b. Set the INTENSITY control for the dimmest, well-defined dot on the CRT.

c. CHECK—Meter for a reading of +20 volts ± 4 volts.

d. ADJUST—INTENSITY control for a meter reading of +20 volts.

e. ADJUST—CRT Grid Bias adjustment, R1480, for the dimmest, well-defined dot visible on the CRT (see Fig. 5-4).

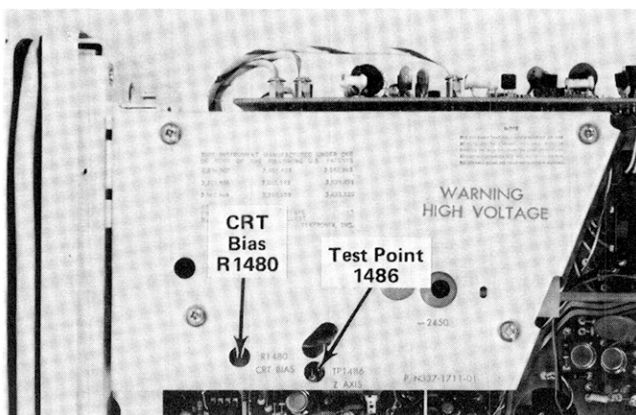

Fig. 5-4. Location of CRT Grid Bias adjustment and test point 1486.

f. Remove the DC Voltmeter connections.

g. Rotate ASTIG control (front panel screwdriver adjustment) through its range.

h. CHECK—For dot de-focus at both extremes of ASTIG control.

i. Reset the ASTIG control for a well-defined dot.

4. Check Display Controls

a. Rotate SCALE ILLUM control through its range.

b. CHECK—For a smooth increase in illumination.

c. Set TIME/DIV to 1 ms and INTENSITY control to midrange.

d. Rotate FOCUS control through its range.

e. CHECK—For trace de-focus at both extremes of FOCUS control.

f. Rotate INTENSITY control from fully counterclockwise to fully clockwise.

g. CHECK—For trace intensity to increase smoothly from minimum to maximum intensity.

h. Reset INTENSITY and FOCUS controls for a well-defined trace.

5. Adjust Trace Alignment

- a. Position the trace to the center horizontal graticule line.
- b. CHECK—That the trace is parallel with the center horizontal line.
- c. ADJUST—TRACE ROTATION adjustment (front panel adjustment) to make the trace parallel to the center horizontal line.

6. Adjust Y Axis Alignment

- a. Connect 0.1 ms time markers from the Time-Mark Generator to the CH 1 input connector via a 42-inch 50 Ω BNC cable and a 50 Ω BNC termination.
- b. Set the CH 1 INPUT COUPLING switch to DC and the CH 1 VOLTS/DIV switch to 0.1 V.
- c. Adjust the A LEVEL control for a stable display; ASTIG and FOCUS controls for a well-defined display.
- d. Adjust the VAR TIME/DIV control for 1 time marker/division.
- e. CHECK—For no more than 0.1 division of tilt of the center time marker as compared with the center vertical graticule line.
- f. ADJUST—Y Axis Alignment adjustment, R1446, (see Fig. 5-5) to align the center time marker with the center vertical graticule line.
- g. INTERACTION—Between Y Axis alignment and TRACE ROTATION adjustments. Readjust until there is no further interaction.

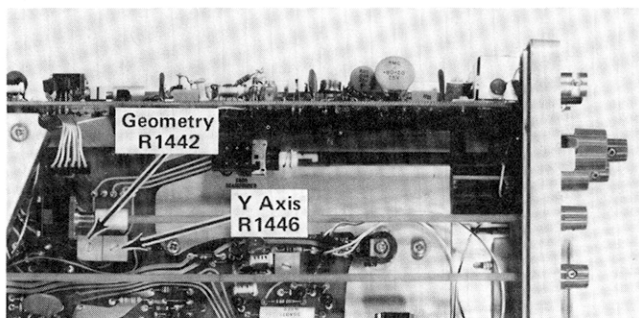

Fig. 5-5. Location of Geometry and Y Axis adjustments.

7. Adjust Geometry

- a. CHECK—CRT display for no more than 0.1 division vertical curvature of the markers across the graticule area.
- b. ADJUST—Geometry adjustment, R1442, (see Fig. 5-5) for minimum curvature of the markers across the graticule area.
- c. Remove the test signal from CH 1 input.
- d. CHECK—For no more than 0.1 division of curvature of the trace when positioned from top to bottom of the graticule area.
- e. INTERACTION—Between Geometry and Y Axis Alignment adjustments. Adjust both for optimum response.

8. Adjust Z Axis Compensation

- a. Set A TIME/DIV to 0.05 μs.
- b. Connect the X10 probe from the Test Oscilloscope to TP1486 (see Fig. 5-6).
- c. Adjust the 465 INTENSITY control for a 15 volt display on the Test Oscilloscope.
- d. CHECK—Test Oscilloscope display for optimum square corner on the unblanking gate.
- e. ADJUST—Z-Axis Compensation adjustment, C1471, using low capacitance screwdriver, (see Fig. 5-6) for optimum square corner on the unblanking gate.
- f. Disconnect the test setup.

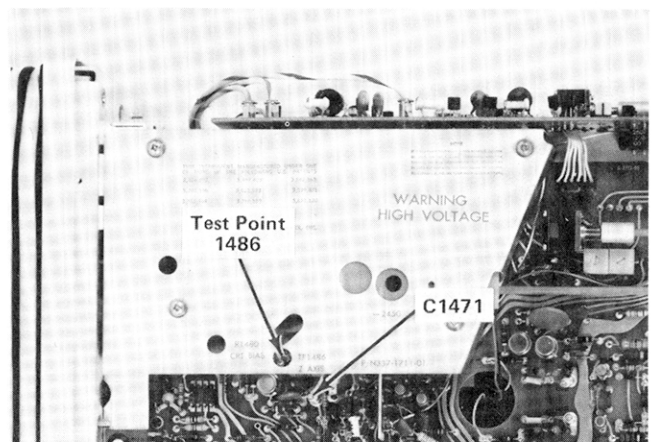

Fig. 5-6. Location of Z-Axis compensation adjustment and test point 1486.

VERTICAL SYSTEM CALIBRATION

Equipment Required

- | | |
|--|---|
| <ol style="list-style-type: none"> 1. High-Frequency Constant-Amplitude Signal Generator (067-0532-01) 2. Medium-Frequency Constant-Amplitude Signal Generator (Type 191) 3. Fast-Rise High-Amplitude Pulse Generator (Type 109) 4. Standard Amplitude Calibrator (067-0502-01) 5. Test Oscilloscope 6. GR-to-BNC Adapter 7. 50 Ω BNC Termination | <ol style="list-style-type: none"> 8. 42-inch 50 Ω BNC Cables (two) 9. X10 Probes (two) 10. X10 BNC Attenuators (two) 11. X10 GR Attenuator 12. 20 pF Input RC Normalizer 13. Low-Capacitance Screwdriver 14. Three-Inch Screwdriver 15. DC Voltmeter 16. Square-Wave Generator (Type 106) |
|--|---|

Control Settings

Preset instrument controls to the settings given under Preliminary Control Settings except as follows:

CH 1 VOLTS/DIV 0.2 V

9. Adjust Vertical Output Amplifier Bias

a. Connect the High-Frequency Constant-Amplitude Signal Generator (067-0532-01) output to the CH 1 input via a GR-to-BNC female adapter and a 50 Ω BNC termination.

b. Adjust the signal generator for a 100 MHz sinewave output.

c. ADJUST—Vertical Output Bias adjustment, R455, (see Fig. 5-7) for maximum deflection of signal.

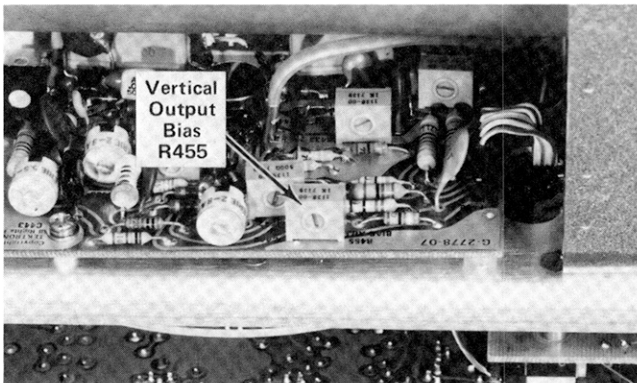

Fig. 5-7. Location of Vertical Output Bias adjustment.

d. INTERACTION—Affects vertical risetime, aberrations, and position effect. This adjustment may be slightly misadjusted for optimum performance of the vertical system.

e. Disconnect the test setup.

10. Adjust Vertical Output Centering and Check BEAM FIND

a. Connect the DC Voltmeter between TP322 and TP324 (see Fig. 5-8).

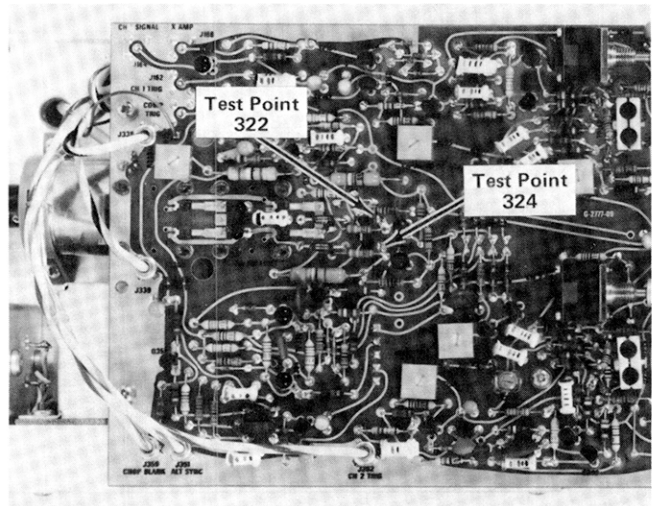

Fig. 5-8. Location of test points 322 and 324.

b. Adjust the CH 1 POSITION control for a 0 volt reading on the meter.

c. ADJUST—Vertical Output Centering adjustment, R429, (see Fig. 5-9) to position the trace to the center graticule line.

d. Remove the DC Voltmeter lead connections.

e. Position the trace off-screen with the CH 1 POSITION and horizontal POSITION controls.

f. Push the BEAM FIND button and hold it in.

g. CHECK—That the trace is brought into the CRT viewing area.

h. Release the BEAM FIND button.

11. Adjust CH 1 Step Attenuator Balance

a. Set the CH 1 VOLTS/DIV switch to 20 mV and the CH 1 INPUT COUPLING switch to GND.

b. Position the trace to the center horizontal graticule line.

c. CHECK—CRT display for 0.2 division or less of trace shift between adjacent switch positions when rotating the CH 1 VOLTS/DIV switch from 20 mV to 5 mV.

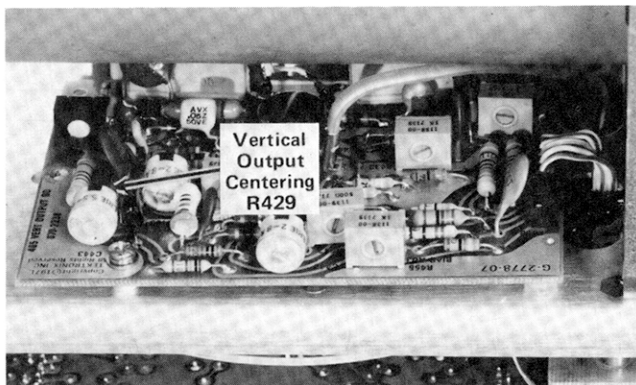

Fig. 5-9. Location of Vertical Output Centering adjustment.

d. ADJUST—CH 1 Step Atten Bal adjustment, R25, (see Fig. 5-10) for minimum trace shift when rotating the CH 1 VOLTS/DIV switch from 20 mV to 5 mV.

12. Adjust CH 1 Variable Volts/Division Balance

a. Position the trace to the center horizontal graticule line.

b. CHECK—That the CH 1 UNCAL light comes on when the VAR control is out of the detent position.

c. CHECK—CRT display for 1.0 division or less of trace shift when rotating the CH 1 VAR control through its range.

d. ADJUST—CH 1 Variable Balance adjustment, R120, (see Fig. 5-11) for minimum trace shift when rotating the CH 1 VAR control through its range.

e. Return the CH 1 VAR control to the detent position.

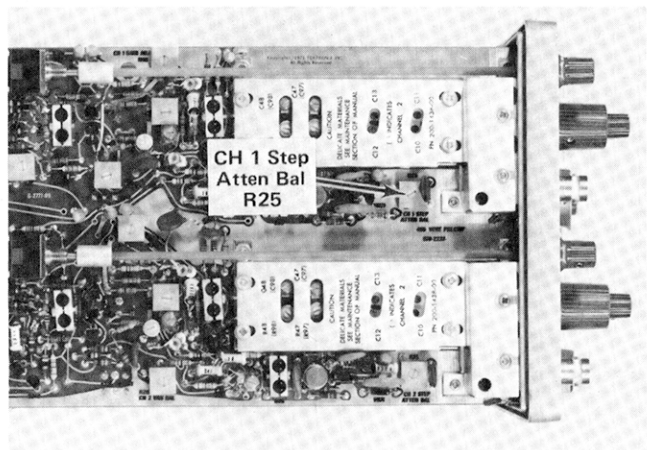

Fig. 5-10. Location of CH 1 Step Atten Bal adjustment.

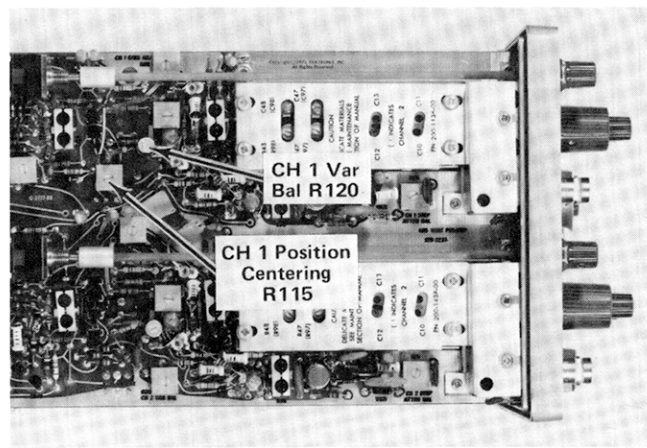

Fig. 5-11. Location of CH 1 Variable Balance and Position Centering adjustment.

13. Check Probe Indicator Lights

- a. Set both VOLTS/DIV switches to 5 mV.
- b. Connect a X10 probe with a scale-factor switching connector to the CH 1 input connector.
- c. CHECK—Light under 5 mV is extinguished and the light under 50 mV comes on.
- d. Set VERT MODE switch to CH 2.
- e. Move the probe to the CH 2 input.
- f. CHECK—Light under 5 mV is extinguished and the light under 50 mV comes on.
- g. Remove the X10 probe.

14. Check INPUT COUPLING Switches

- a. Set both INPUT COUPLING switches to DC.
- b. Connect the Standard Amplitude Calibrator output to the CH 2 input via a 42-inch 50 Ω BNC cable.
- c. Adjust the Standard Amplitude Calibrator for 20 mV output.
- d. Position the bottom of the display to the center horizontal graticule line.
- e. Set CH 2 INPUT COUPLING switch to GND.
- f. CHECK—For no vertical deflection; trace is at center horizontal graticule line.
- g. Set CH 2 INPUT COUPLING switch to AC.
- h. CHECK—That display is centered about the center horizontal graticule line.
- i. Move the test signal to CH 1.
- j. Position the bottom of the display to the center horizontal graticule line.

- k. Set CH 1 INPUT COUPLING switch to GND.
- l. Repeat step 14-f.
- m. Set CH 1 INPUT COUPLING switch to AC.
- n. Repeat step 14-h.

15. Adjust CH 1 Position Centering

- a. Set the CH 1 VOLTS/DIV switch to 20 mV.
- b. Adjust the Standard Amplitude Calibrator for 500 mV output.
- c. CHECK—That the top of the CRT display can be positioned down to 1/2-division above the center horizontal graticule line, and the bottom of the display can be positioned up to 1/2-division below the center horizontal graticule line.
- d. ADJUST—CH 1 Position Centering adjustment, R115, (see Fig. 5-11) so that the top of the CRT display can be positioned down to 1/2-division above the center horizontal graticule line, and the bottom of the display can be positioned up to 1/2-division below the center horizontal graticule line.
- e. INTERACTION—Between CH 1 Position Centering and CH 1 Variable Volts/Division Balance adjustments. Re-adjust both until no interaction is visible.

16. Adjust CH 2 Step Attenuator Balance

- a. Set the VERT MODE switch to CH 2; CH 2 VOLTS/DIV switch to 20 mV.
- b. Position the trace to the center horizontal graticule line.
- c. CHECK—CRT display for 0.2 division or less of trace shift between adjacent switch positions when rotating the CH 2 VOLTS/DIV switch from 20 mV to 5 mV.
- d. ADJUST—CH 2 Step Atten Bal adjustment, R75, (see Fig. 5-12) for minimum trace shift when rotating the CH 2 VOLTS/DIV switch from 20 mV to 5 mV.

17. Adjust CH 2 Variable Volts/Division Balance

- a. CHECK—That the CH 2 UNCAL light comes on when the CH 2 VAR control is out of the detent position.
- b. CHECK—CRT display for 1.0 division or less of trace shift when rotating the CH 2 VAR control through its range.
- c. ADJUST—CH 2 Variable Balance adjustment, R220, (see Fig. 5-13) for minimum trace shift when rotating the CH 2 VAR control through its range.
- d. Return the VAR control to the detent position.

18. Adjust CH 2 Position Centering

- a. Move the test signal from CH 1 to the CH 2 input.
- b. Set the CH 2 VOLTS/DIV switch to 20 mV; and the VERT MODE switch to CH 2.

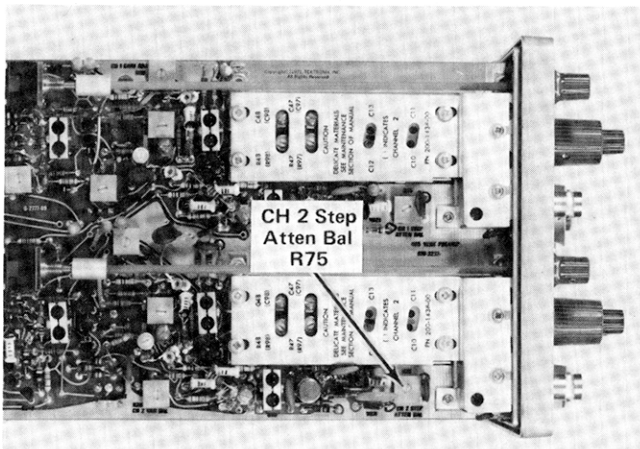

Fig. 5-12. Location of CH 2 Step Atten Bal adjustment.

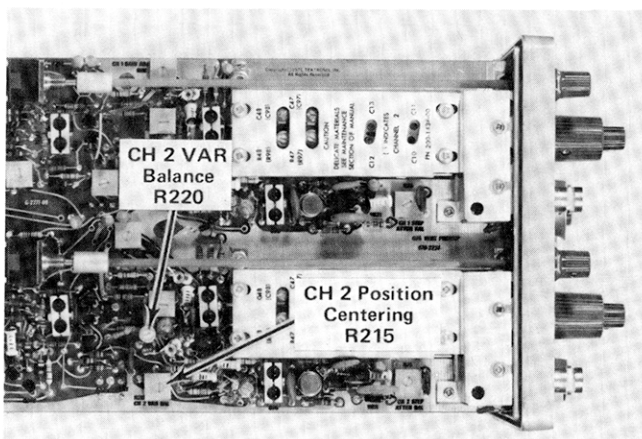

Fig. 5-13. Location of CH 2 Variable Balance and Position Centering adjustments.

- c. Adjust the Standard Amplitude Calibrator for a 500 mV output.

- d. CHECK—That the top of the CRT display can be positioned down to 1/2-division above the center horizontal graticule line, and the bottom of the display can be positioned up to 1/2-division below the center horizontal graticule line.

- e. ADJUST—CH 2 Position Centering adjustment, R215, (see Fig. 5-13) so that the top of the CRT display can be positioned down to 1/2-division above the center horizontal graticule line, and the bottom of the display can be positioned up to 1/2-division below the center horizontal graticule line.

- f. INTERACTION—Between CH 2 Position Centering and CH 2 Variable Volts/Division Balance adjustments. Re-adjust both until no interaction is visible.

19. Check CH 2 INVERT Balance

- a. Set the CH 2 INPUT COUPLING switch to GND.
- b. Position the trace to the center horizontal graticule line.
- c. Push the INVERT button.
- d. CHECK—For less than 2 division of trace shift when switching from normal to inverted.

20. Adjust CH 1 Gain

- a. Set the VERT MODE switch to CH 1, the CH 1 VOLTS/DIV switch to 5 mV, and the CH 1 INPUT COUPLING switch to DC.

- b. Move the test signal to the CH 1 input.

- c. Adjust the Standard Amplitude Calibrator for a 20 mV output.

- d. Set the Test Oscilloscope: Vertical Mode to ADD, Channel 2 to INVERT, and both VOLTS/DIV switches to 5 mV.

- e. Connect two X10 probes from the Test Oscilloscope to TP322 and TP324 on the Preamp board of the 465 (see Fig. 5-8).

- f. CHECK—The Test Oscilloscope for a 200 mV (peak-to-peak) signal between TP322 and TP324.

Calibration—465

g. ADJUST—CH 1 Gain adjustment, R118, (see Fig. 5-14) for 200 mV (peak-to-peak) display on the Test Oscilloscope. (NOTE: This is a nominal value for this adjustment and may vary from instrument to instrument.

h. Remove the X10 probes from TP322 and TP324.

i. CHECK—CRT display for 4 divisions of deflection within 3% (0.12 div).

j. ADJUST—Vertical Output Gain adjustment, R400, (see Fig. 5-15) for 4 divisions of deflection.

k. CHECK—Accuracy of CH 1 VOLTS/DIV switch using the settings given in Table 5-6 to see if the deflection factor accuracy for each position is within 3%.

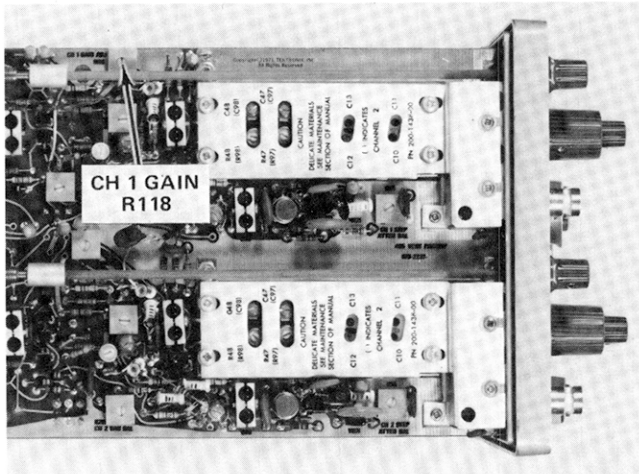

Fig. 5-14. Location of CH 1 Gain adjustment.



Fig. 5-15. Location of Vertical Output Gain adjustment.

21. Adjust CH 2 Gain

a. Set the CH 2 VOLTS/DIV switch to 5 mV, the VERT MODE switch to CH 2, and the CH 2 INPUT COUPLING switch to DC.

b. Move the test signal to CH 2 input connector.

c. Adjust the Standard Amplitude Calibrator for a 20 mV output.

d. CHECK—CRT display for 4 divisions of deflection within 3%.

e. ADJUST—CH 2 Gain adjustment R218 (see Fig. 5-16) for 4 divisions of deflection.

f. CHECK—Accuracy of the CH 2 VOLTS/DIV switch using the settings given in Table 5-6. Deflection factor accuracy to be within 3% in all switch positions.

TABLE 5-6

Vertical Deflection Accuracy

| VOLTS/DIV Switch Setting | Standard Amplitude Calibrator Output | Vertical Deflection in Divisions | Maximum Error for 3% Accuracy |
|--------------------------|--------------------------------------|----------------------------------|-------------------------------|
| 5 m | 20 millivolts | 4 | Previously set |
| 10 m | 50 millivolts | 5 | ±0.15 division |
| 20 m | 0.1 volt | 5 | ±0.15 division |
| 50 m | 0.2 volt | 4 | ±0.12 division |
| .1 | 0.5 volt | 5 | ±0.15 division |
| .2 | 1 volt | 5 | ±0.15 division |
| .5 | 2 volts | 4 | ±0.12 division |
| 1 | 5 volts | 5 | ±0.15 division |
| 2 | 10 volts | 5 | ±0.15 division |
| 5 | 20 volts | 4 | ±0.12 division |

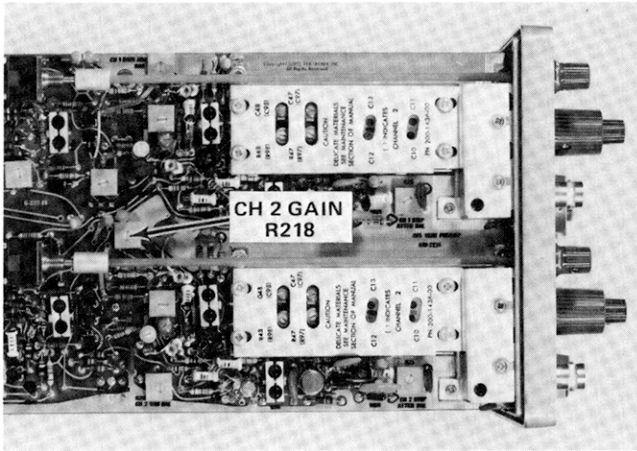

Fig. 5-16. Location of CH 2 Gain adjustment.

22. Check CH 2 and CH 1 Variable Volts/Division Ranges

- a. Adjust the Standard Amplitude Calibrator for 5 divisions of deflection.
- b. Rotate the CH 2 VAR control fully counterclockwise.
- c. CHECK—CRT display reduces to less than 2 divisions.
- d. Move the test signal to the CH 1 input connector.
- e. Set the VERT MODE switch to CH 1.
- f. Adjust the Standard Amplitude Calibrator for 5 divisions of deflection.
- g. Rotate the CH 1 VAR control fully counterclockwise.
- h. CHECK—CRT display reduces to less than 2 divisions.
- i. Return the VAR controls to the detent positions.

23. Check Vertical ADD Mode Operation

- a. Set both VOLTS/DIV switches to 5 mV and both INPUT COUPLING switches to DC.
- b. Connect the Standard Amplitude Calibrator output to both channel inputs via a dual input coupler.

c. Adjust the Standard Amplitude Calibrator for a 10 mV output.

d. Set the VERT MODE switch to ADD.

e. CHECK—If CH 1 and CH 2 Gain adjustments were changed, check for 4 divisions of deflection within 1% (within 3% if CH 1 and CH 2 Gain adjustments were not changed).

24. Check Compression and Expansion

- a. Set the CH 2 INPUT COUPLING switch to GND and the VERT MODE switch to CH 1.
- b. Adjust the CH 1 VAR control for 2 divisions of deflection centered about the center horizontal graticule line.
- c. Position the top of the display to the top graticule line.
- d. CHECK—CRT display for 0.1 division or less of compression or expansion.
- e. Position the bottom of the display to the bottom graticule line.
- f. CHECK—CRT display for 0.1 division or less of compression or expansion.
- g. Set the CH 1 VAR control to the detent position.
- h. Disconnect the test setup.

25. Check Vertical ALT Mode Operation

- a. Set the VERT MODE switch to ALT, and the A Trigger LEVEL control fully clockwise.
- b. Position the two traces 2 divisions apart.
- c. CHECK—That the sweeps alternate at all settings of the A TIME/DIV switch except X-Y.

26. Check Vertical CHOP Mode Operation

a. Set the A TIME/DIV switch to $1\ \mu\text{s}$, the A SOURCE switch to NORM, the A SLOPE switch to +, the VERT MODE switch to CHOP, and both INPUT COUPLING switches to GND.

b. Position the two traces about 4 divisions apart.

c. Adjust the A LEVEL control for a stable display.

d. CHECK—For complete blanking of switching transients between chopped segments (see Fig. 5-17).

e. CHECK—Duration of each cycle is about four divisions.

27. Adjust Vertical Output Low-Frequency Compensation

a. Set the A TIME/DIV switch to 0.2 ms, the VERT MODE switch to CH 1, both INPUT COUPLING switches to DC, and both VOLTS/DIV switches to 5 mV.

b. Connect the fast-rise output of the Square-Wave Generator (Type 106) to the CH 1 input via a GR-to-BNC adapter, 42-inch $50\ \Omega$ BNC cable, X10 BNC attenuator, and a $50\ \Omega$ BNC termination.

c. Adjust the Square-Wave Generator to maintain a five division display throughout this step.

d. Adjust the Square-Wave Generator for a 1 kHz signal output.

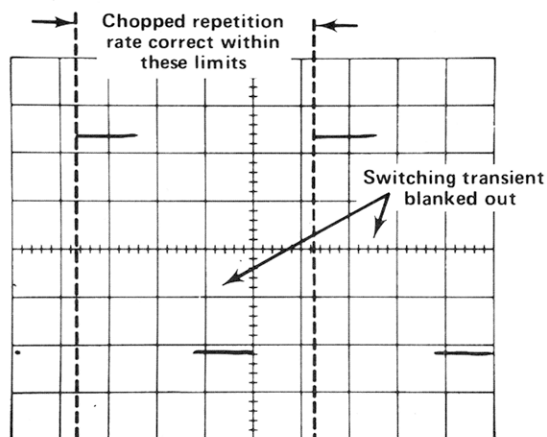

Fig. 5-17. Typical CRT display when checking chopped repetition rate and blanking.

e. Adjust the A LEVEL control for a stable display.

f. CHECK—CRT display for flat-top waveform with no more than 3% overshoot or roll-off on the leading edge.

g. ADJUST—R424 (see Fig. 5-18) for best flat-top waveform.

h. Set the A TIME/DIV switch to $20\ \mu\text{s}$ and adjust the Square-Wave Generator for a 10 kHz signal output.

i. CHECK—CRT display for flat-top waveform with no more than 3% overshoot or roll-off on the leading edge.

j. ADJUST—R434 (see Fig. 5-18) for best flat-top waveform.

k. Set the A TIME/DIV switch to $2\ \mu\text{s}$ and adjust the Square-Wave Generator for a 100 kHz signal output.

l. CHECK—CRT display for flat-top waveform with no more than 3% overshoot or roll-off on the leading edge.

m. ADJUST—R433 (see Fig. 5-18) for best flat-top waveform.

n. INTERACTION—Between all adjustments in this step. Re-adjust, if necessary, for total optimum response.

28. Adjust CH 1 VOLTS/DIV Compensation

a. Add a 20 pf Normalizer to the test setup between the $50\ \Omega$ BNC termination and the CH 1 input.

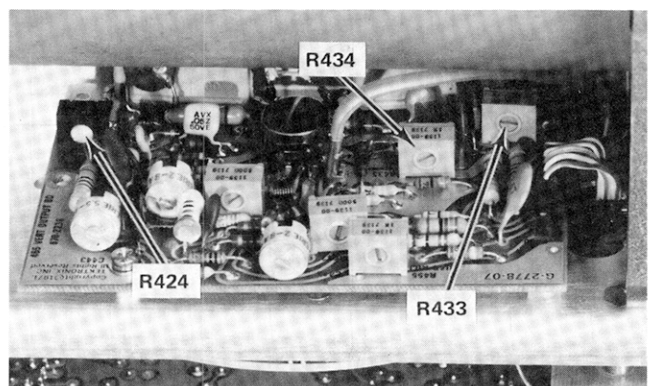

Fig. 5-18. Location of Vertical Output Low-Frequency Compensation adjustments.

b. Move the test setup from the fast-rise output to the high-amplitude output of the Square-Wave Generator (Type 106) and adjust the generator for a one-kilohertz output signal.

c. Adjust the Square-Wave Generator for a five division display. Add or remove attenuators as necessary to maintain a five division display throughout this step.

d. CHECK—CRT display for flat-top waveform with no more than 2% overshoot or roll-off on the leading edge.

e. ADJUST—C1 (see Fig. 5-19) with the low-capacitance screwdriver for best flat-top waveform.

f. Set the CH 1 VOLTS/DIV switch to 50 mV.

g. CHECK—CRT display for flat-top waveform with no more than 2% overshoot or roll-off on the leading edge.

h. ADJUST—Channel 1 C13 (see Fig. 5-19) for best flat-top waveform, and Channel 1 C12 for the best corner with the low-capacitance screwdriver.

i. CAL AID—Remove the 20 pf Normalizer when adjusting or checking the corner response.

j. INTERACTION—Between Channel 1's C13 and C12. Readjust both for total optimum response.

k. Set the CH 1 VOLTS/DIV switch to 0.5 V.

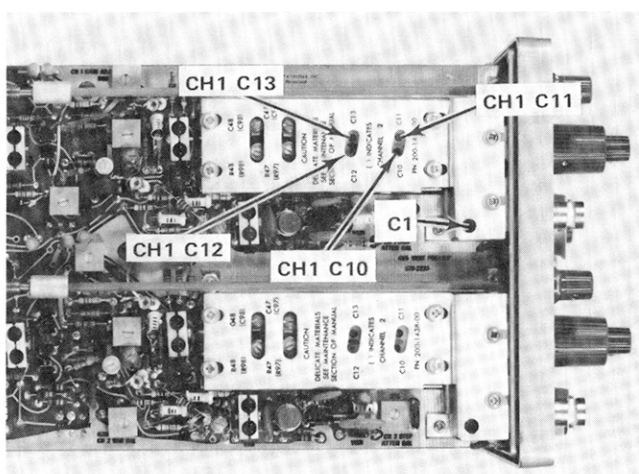

Fig. 5-19. Location of CH 1 volts/div compensation adjustments.

l. CHECK—CRT display for flat-top waveform with no more than 2% overshoot or roll-off on the leading edge.

m. ADJUST—Channel 1 C11 (see Fig. 5-19) for best flat-top waveform, and Channel 1 C10 for the best corner, with the low-capacitance screwdriver.

n. Set the CH 1 VOLTS/DIV switch to 5 V.

o. CHECK—CRT display for flat-top waveform with no more than 2% overshoot or roll-off on the leading edge.

29. Adjust CH 2 VOLTS/DIV Compensation

a. Set the VERT MODE switch to CH 2 and move the test signal to the CH 2 input.

b. Adjust the Square-Wave Generator (Type 106) for a five-division display. Remove or add attenuators as necessary to maintain a five-division display.

c. CHECK—CRT display for flat-top waveform with no more than 2% overshoot or roll-off on the leading edge.

d. ADJUST—C51 (see Fig. 5-20) with the low-capacitance screwdriver, for best flat-top waveform.

e. Set the CH 2 VOLTS/DIV switch to 50 mV.

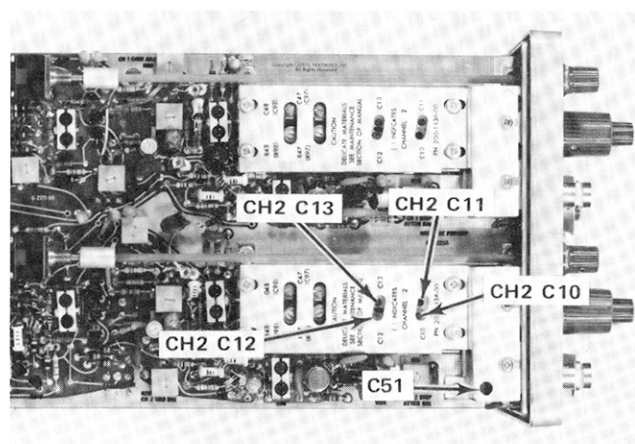

Fig. 5-20. Location of CH 2 volts/div compensation adjustments.

Calibration—465

f. CHECK—CRT display for flat-top waveform with no more than 2% overshoot or roll-off on the leading edge.

g. ADJUST—Channel 2 C13 (see Fig. 5-20) for best flat-top waveform, and Channel 2 C12 for the best corner, with the low-capacitance screwdriver.

h. CAL AID—Remove the 20 pf Normalizer when adjusting or checking the corner response.

i. INTERACTION—Between Channel 2's C13 and C12. Readjust both for total optimum response.

j. Set the CH 2 VOLTS/DIV switch to 0.5 V.

k. CHECK—CRT display for flat-top waveform with no more than 2% overshoot or roll-off on the leading edge.

l. ADJUST—Channel 2 C11 (see Fig. 5-20) for best flat-top waveform, and Channel 2 C10 for the best corner, with the low-capacitance screwdriver.

m. INTERACTION—Between Channel 2's C11 and C10. Readjust both for optimum response.

n. Set the CH 2 VOLTS/DIV switch to 5 V.

o. CHECK—CRT display for flat-top waveform with no more than 2% overshoot or roll-off on the leading edge.

p. Disconnect the test setup.

30. Adjust Channel 2 and Vertical Output High-Frequency Compensation

a. Set both VOLTS/DIV switches to 5 mV, the VERT MODE switch to CH 2, the A TIME/DIV switch to 0.05 μ s, and the A SLOPE to +.

b. Connect the Fast-Rise High-Amplitude Pulse Generator (Type 109) to the CH 2 input via a GR-to-BNC adapter, 42-inch 50 Ω BNC cable, two X10 BNC attenuators, and a 50 Ω BNC termination.

c. Set the Pulse Generator polarity to + and the voltage range to 50 V.

d. Adjust the Pulse Generator for five divisions of deflection. Remove or add attenuators as necessary to maintain a five division display throughout this step.

e. CHECK—CRT display for risetime of 3.5 nanoseconds or less.

f. CHECK—CRT display for flat-top waveform with 3% or less of aberrations.

g. ADJUST—C77, C83, C205, R205, C249, R249, C402, C442, R442, and C443 (see Fig. 5-21 and 5-22) with a low-capacitance screwdriver, for the best flat-top waveform.

h. Set the Pulse Generator polarity to - and the 465 A SLOPE switch to -.

i. CHECK—CRT display for flat-bottom waveform with 5% or less of aberrations.

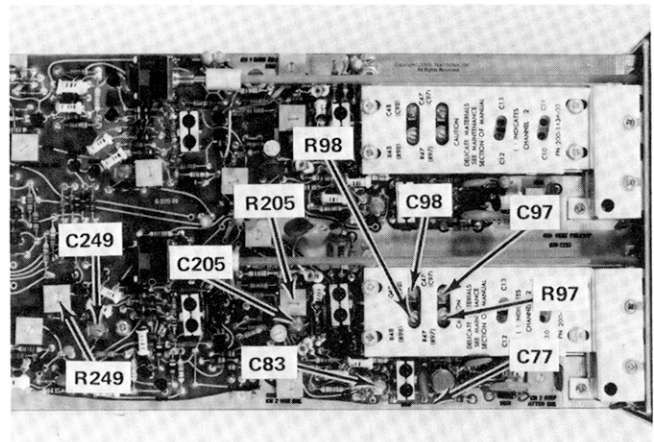

Fig. 5-21. Location of part of the CH 2 High-Frequency Compensation adjustments.

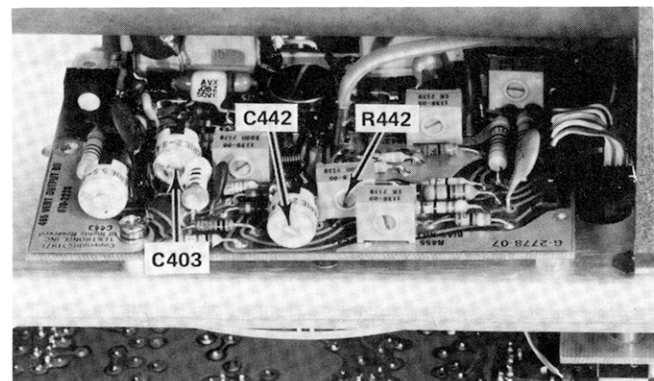

Fig. 5-22. Location of Vertical Output High-Frequency Compensation adjustments.

j. CAL AID—The above adjustments also affect the negative-step aberrations. Adjust for optimum response and minimum aberrations on both the positive- and negative-going steps.

k. Set the A SLOPE control to + and the Pulse Generator polarity to +.

l. Set the CH 2 VOLTS/DIV switch to 10 mV.

m. CHECK—CRT display for risetime of 3.5 nanoseconds or less.

n. CHECK—CRT display for flat-top waveform with 3% or less of aberrations.

o. ADJUST—R97 and C97 (see Fig. 5-21) for optimum risetime and aberrations.

p. Set the Pulse Generator polarity to – and the 465 A SLOPE switch to –.

q. CHECK—CRT display for best corner and flat-bottom waveform with 5% or less aberrations.

r. Set the CH 2 VOLTS/DIV switch to 20 mV and the A SLOPE switch to +.

s. Set the Pulse Generator polarity to +.

t. CHECK—CRT display for risetime of 3.5 nanoseconds or less.

u. CHECK—CRT display for flat-top waveform with 3% or less of aberrations.

v. ADJUST—R98 and C98 (see Fig. 5-21) for optimum risetime and aberrations.

w. Set the Pulse Generator polarity to – and the 465 A SLOPE switch to –.

x. CHECK—CRT display for flat-bottom waveform with 5% or less of aberrations.

y. Set the CH 2 VOLTS/DIV switch to 50 mV.

z. Set the A SLOPE switch to + and the Pulse Generator polarity to +.

aa. CHECK—CRT display for risetime of 3.5 nanoseconds or less.

ab. CHECK—CRT display for flat-top waveform with 3% or less of aberrations.

ac. Set the Pulse Generator polarity to – and the 465 A SLOPE switch to –.

ad. CHECK—CRT display for best corner and flat-bottom waveform with 5% or less aberrations.

ae. Repeat step 30-z through 30-ad for each setting of the CH 2 VOLTS/DIV switch from 0.1 V to 5 V.

31. Check CH 2 Position Effect

a. Set the CH 2 VOLTS/DIV switch to 5 mV.

b. Adjust the Pulse Generator (Type 109) for five divisions of display.

c. Adjust the A LEVEL control for a stable display.

d. Position the top of the display to the bottom graticule line.

e. CHECK—CRT display for less than 5% aberrations.

f. Set the Pulse Generator polarity to – and the 465 A SLOPE switch to –.

g. Position the bottom of the display to the top graticule line.

h. CHECK—CRT display for less than 7% aberrations.

32. Adjust CH 1 High-Frequency Compensation

a. Move the test signal from CH 2 to the CH 1 input.

b. Set the A TIME/DIV switch to 0.05 μ s, the A SLOPE switch to +, and the VERT MODE switch to CH 1.

Calibration—465

c. Set the Fast-Rise High-Amplitude Pulse Generator (Type 109) to + and adjust the Pulse Generator for five divisions of deflection. Remove or add attenuators as necessary to maintain a five-division display throughout this step.

d. CHECK—CRT display for risetime of 3.5 nanoseconds or less.

e. CHECK—CRT display for flat-top waveform with 3% or less of aberrations.

f. ADJUST—C27, C33, C105, R105, C122, R122, C149, and R149 (see Fig. 5-23) with a low-capacitance screwdriver, for the best flat-top waveform.

g. Set the Pulse Generator polarity to – and the 465 A SLOPE switch to –.

h. CHECK—CRT display for flat-bottom waveform with 5% or less of aberrations.

i. CAL AID—The above adjustments also affect the negative-step aberrations. Adjust them for optimum response and minimum aberrations on both the positive- and negative-going steps.

j. Set the A SLOPE control to + and the Pulse Generator polarity to +.

k. Set the CH 1 VOLTS/DIV switch to 10 mV.

l. CHECK—CRT display for risetime of 3.5 nanoseconds or less.

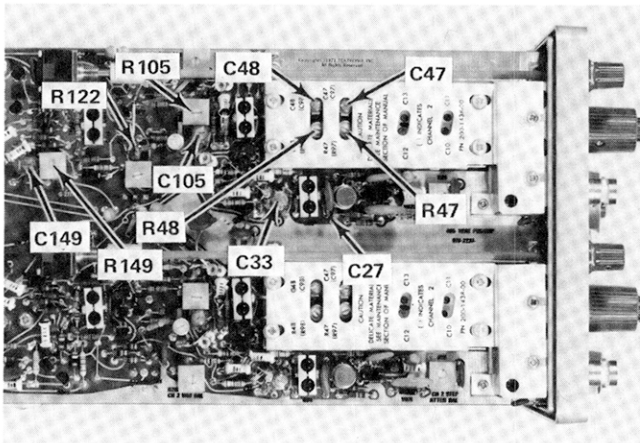

Fig. 5-23. Location of CH 1 High-Frequency Compensation adjustment.

m. CHECK—CRT display for flat-top waveform with 3% or less of aberrations.

n. ADJUST—R47 and C47 (see Fig. 5-23) for optimum risetime and aberrations.

o. Set the Pulse Generator polarity to – and the 465 A SLOPE switch to –.

p. CHECK—CRT display for best corner and flat-bottom waveform with 5% or less aberrations.

q. Set the CH 1 VOLTS/DIV switch to 20 mV and the A SLOPE switch to +.

r. Set the Pulse Generator polarity to +.

s. CHECK—CRT display for risetime of 3.5 nanoseconds or less.

t. CHECK—CRT display for flat-top waveform with 3% or less of aberrations.

u. ADJUST—R48, and C48 (see Fig. 5-23) for optimum risetime and aberrations.

v. Set the Pulse Generator polarity to – and the 465 A SLOPE switch to –.

w. CHECK—CRT display for flat-bottom waveform with 5% or less of aberrations.

x. Set the CH 1 VOLTS/DIV switch to 50 mV.

y. Set the A SLOPE switch to + and the Pulse Generator polarity to +.

z. CHECK—CRT display for risetime of 3.5 nanoseconds or less.

aa. CHECK—CRT display for flat-top waveform with 3% or less of aberrations.

ab. Set the Pulse Generator polarity to – and the 465 A SLOPE switch to –.

ac. CHECK—CRT display for best corner and flat-bottom waveform with 5% or less aberrations.

ad. Repeat step 32-y through 32-ac for each setting of the CH 1 VOLTS/DIV switch from 0.1 V to 5 V.

33. Check CH 1 Position Effect

a. Set the CH 1 VOLTS/DIV switch to 5 mV.

b. Adjust the Pulse Generator (Type 109) for five divisions of display.

c. Adjust the A LEVEL control for a stable display.

d. Position the top of the display to the bottom graticule line.

e. CHECK—CRT display for less than 5% aberrations.

f. Set the Pulse Generator polarity to — and the 465 A SLOPE switch to —.

g. Position the bottom of the display to the top graticule line.

h. CHECK—CRT display for less than 7% aberrations.

i. Disconnect the test setup.

34. Check Vertical Amplifier Bandwidth

a. Connect the output of the High-Frequency Constant-Amplitude Signal Generator (067-0532-01) to the CH 1 input via a GR-to-BNC adapter, X10 BNC attenuator, and a 50 Ω BNC termination.

b. Set the TRIG MODE switch to AUTO, A TIME/DIV switch to 0.2 ms, both VOLTS/DIV switches to 5 mV and the VERT MODE switch to CH 1.

c. Adjust the High-Frequency signal generator output amplitude for a five division display of a 3 megahertz reference signal.

d. Without changing the output amplitude, increase the output frequency of the signal generator until the display is reduced to 3.5 divisions.

e. CHECK—Output frequency of the signal generator must be at least 100 megahertz (0°C to +40°C).

f. Repeat this bandwidth check procedure, steps 34-c through 34-e, for settings of the CH 1 VOLTS/DIV switch from 10 mV to 2 V.

g. Move the test signal to CH 2 input, set the VERT MODE switch to CH 2, and the CH 2 INPUT COUPLING switch to DC.

h. Repeat this bandwidth check, step 34-c through 34-e, for settings of the CH 2 VOLTS/DIV switch from 5 mV to 2 V.

i. Disconnect the test setup.

35. Check Cascaded Gain and Bandwidth

a. Set both INPUT COUPLING switches to DC, the VERT MODE switch to CH 2, both VOLTS/DIV switches to 5 mV, and the A TIME/DIV switch to 1 ms.

b. Connect the CH 1 VERT SIGNAL OUT (on the rear panel) to the CH 2 input connector via a 42-inch 50 Ω BNC cable and a 50 Ω BNC termination.

c. Connect the Standard Amplitude Calibrator to the CH 1 input via a 42-inch 50 Ω BNC cable.

d. Adjust the Standard Amplitude Calibrator for a 5 mV output.

e. CHECK—CRT display for at least five divisions of deflection.

f. Remove the test setup from the CH 1 input.

g. Connect the output of the Medium-Frequency Constant-Amplitude Signal Generator (Type 191) to the CH 1 input via a GR-to-BNC adapter, 42-inch 50 Ω BNC cable, X10 BNC attenuator, and a 50 Ω BNC termination.

Calibration—465

- h. Adjust the Medium-Frequency signal generator for a five-division display of a 50 kilohertz reference signal.
- i. Without changing the output amplitude of the signal generator, increase the output frequency until the display is reduced to 3.5 divisions.
- j. CHECK—Output frequency of the signal generator must be at least 50 megahertz.
- k. Disconnect the test setup.

36. Check Vertical Channel Isolation

- a. Move the test signal to the CH 2 input after removing the X10 attenuator.
- b. Set CH 2 VOLTS/DIV switch to 0.2 V, CH 1 INPUT COUPLING switch to GND, and VERT MODE switch to CH 2.
- c. Adjust the Medium-Frequency signal generator for a 2 division display of a 25 megahertz signal.
- d. Set both VOLTS/DIV switches to 20 mV and VERT MODE switch to CH 1.
- e. CHECK—CRT display for no more than 0.2 division of deflection.
- f. Move the CH 2 input test setup to the CH 1 input.
- g. Set the CH 1 INPUT COUPLING switch to DC, CH 2 INPUT COUPLING switch to GND, CH 1 VOLTS/DIV switch to 0.2 V.
- h. Adjust the Medium-Frequency signal generator for a 2 division display of a 25 megahertz signal.
- i. Set VERT MODE switch to CH 2.
- j. CHECK—CRT display for no more than 0.2 division of deflection.
- k. Disconnect the test setup.

37. Check Common-Mode Rejection Ratio

- a. Set both VOLTS/DIV switches to 5 mV, both INPUT COUPLING switches to DC, the VERT MODE switch to CH 1, and push the CH 2 INVERT switch.
- b. Connect the output of the Medium-Frequency Constant-Amplitude Signal Generator (Type 191) to the CH 1 and CH 2 inputs via a GR-to-BNC adapter, 42-inch 50 Ω BNC cable, X10 BNC attenuator, 50 Ω BNC termination, and a dual-input coupler.
- c. Adjust the Medium-Frequency Signal Generator for a six-division display of the 50-kilohertz reference signal.

- d. Set the VERT MODE switch to ADD and adjust the CH 2 Gain adjust for minimum deflection (best CMRR).
- e. Without increasing the output signal amplitude, increase the Type 191 output signal frequency to 20 MHz.
- f. CHECK—CRT display for no more than 0.6 division of signal amplitude (indicates CMRR of at least 10:1 at 20 MHz).
- g. Release the CH 2 INVERT switch and disconnect the test setup.

38. Check Bandwidth Limit Operation

- a. Pull the 20 MHz BW/TRIG VIEW button to BW and set the CH 1 INPUT COUPLING switch to DC.
- b. Connect the Medium-Frequency Constant-Amplitude Signal Generator (Type 191) to the CH 1 input via a 42-inch 50 Ω BNC cable and a 50 Ω BNC termination.
- c. Adjust the Medium-Frequency signal generator for a six-division display of a 50 kilohertz signal.
- d. Increase the output frequency of the signal generator until the display is reduced to 4.2 divisions.
- e. CHECK—Output frequency of the signal generator is between 16 and 24 megahertz.
- f. Disconnect the test setup.

TRIGGER SYSTEM CALIBRATION

Equipment Required

- | | |
|---|--|
| <ol style="list-style-type: none"> 1. Medium-Frequency Constant-Amplitude Signal Generator (Type 191) 2. Low-Frequency Sine-Wave Generator (General Radio 1310-A) 3. Time-Mark Generator (Type 2901) 4. Standard Amplitude Calibrator 5. 50 Ω Signal Pickoff Unit (Type CT-3) 6. X10 Probe 7. 42-Inch 50 Ω BNC Cable | <ol style="list-style-type: none"> 8. GR-to-BNC Female Adapter 9. X10 BNC Attenuator 10. 50 Ω BNC Termination 11. Dual-Input Coupler (two) 12. BNC-T Connector 13. 18-inch 50 Ω BNC Cable (two) 14. X2 BNC Attenuator 15. 50 Ω 5 ns GR Cable |
|---|--|

Control Settings

Preset instrument controls to the settings given under Preliminary Control Settings except as follows:

| | |
|----------------|---------|
| CH 1 VOLTS/DIV | 10 mV |
| both TIME/DIV | 0.05 μs |
| A TRIGGER | |
| SOURCE | EXT |
| COUPLING | AC |
| SLOPE | + |

39. Adjust A Trigger Sensitivity

a. Connect the output of the Medium-Frequency Constant-Amplitude Signal Generator (Type 191) to the A and B External Trigger Inputs via a 50 Ω 5 ns GR cable, 50 Ω Signal Pickoff Unit (Type CT-3) thru output, GR-to-BNC adapter, X10 BNC attenuator, a 50 Ω BNC termination, and a dual input coupler.

b. Connect the 10% BNC output connector of the Signal Pickoff Unit (Type CT-3) to the CH 1 and CH 2 inputs via a 50 Ω BNC termination, and a dual input coupler.

c. Adjust the Medium-Frequency signal generator output for a 3-division display of a 25 megahertz signal.

d. Set the CH 1 VOLTS/DIV switch to 0.1 V.

e. CHECK—That a stable display can just be obtained by rotating the A LEVEL control.

f. Adjust the Medium-Frequency signal generator to reduce the CRT display to 0.25 division.

g. ADJUST—A Trigger Sensitivity adjustment, R655, (see Fig. 5-24) so that a stable display can just be obtained by rotating the A LEVEL control.

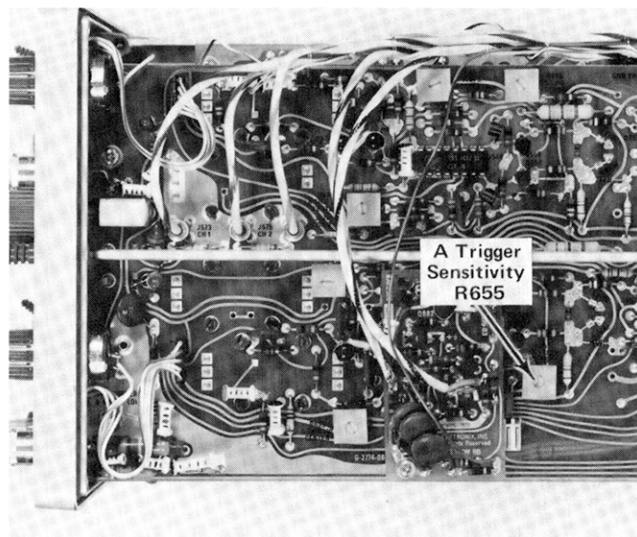

Fig. 5-24. Location of A Trigger Sensitivity adjustment.

40. Adjust B Trigger Sensitivity

a. Set the HORIZ DISPLAY switch to B DLY'D, the B COUPLING switch to AC, the B SOURCE switch to EXT, and the B SLOPE to +.

b. Adjust the Medium-Frequency signal generator for a 0.3 division display.

c. CHECK—That a stable display can just be obtained by rotating the B LEVEL control.

d. Adjust the Medium-Frequency signal generator to reduce the CRT display to 0.25 division.

e. ADJUST—B Trigger Sensitivity adjustment, R555, (see Fig. 5-25) so that a stable display can just be obtained by rotating the B LEVEL control.

41. Adjust B Trigger Slope and Level Centering

a. Set both TIME/DIV switches to 10 μ s, both LEVEL controls to 0, and the CH 1 VOLTS/DIV switch to 10 mV.

b. Adjust the Medium-Frequency signal generator for a 0.3 division display of a 50 kilohertz signal.

c. Vertically center the display about the center vertical graticule line.

d. CHECK—CRT display begins at the same vertical point of the signal in both the + and - slope.

e. ADJUST—B Trigger Level Centering adjustment, R535, (see Fig. 5-25) for the trigger point of the display to be at the graticule center, and adjust the B Trigger Slope Centering adjustment, R545, (see Fig. 5-25) so that the trace begins at the graticule center in both the + and - slope.

42. Adjust A Trigger Slope and Level Centering

a. Set the HORIZ DISPLAY switch to A and the A LEVEL control to 0.

b. CHECK—CRT display begins at the same vertical point of the signal in both the + and - slope.

c. ADJUST—A Trigger Level Centering adjustment, R635, (see Fig. 5-26) for the trigger point of the display to be at the graticule center, and adjust the B Trigger Slope Centering adjustment, R645 (see Fig. 5-26) so that the trace begins at the graticule center in both the + and - slope.

43. Adjust A Trigger DC Levels

a. Set the A COUPLING switch to DC, the A SOURCE switch to NORM, and the A LEVEL control to 0.

b. Adjust the Medium-Frequency signal generator for a 0.3 division display.

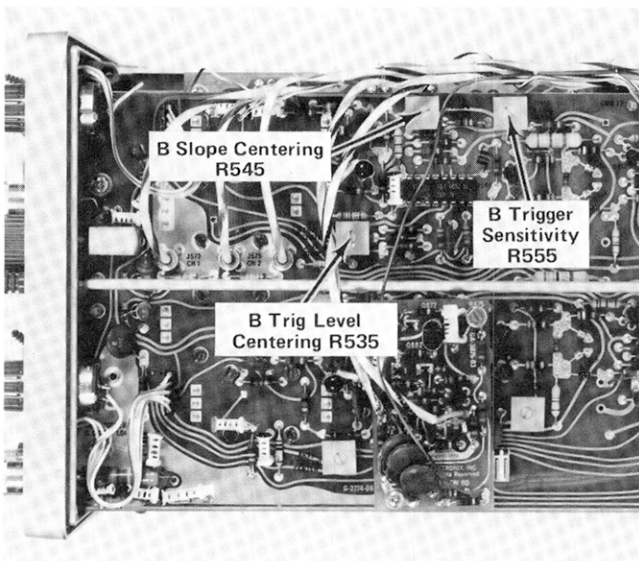

Fig. 5-25. Location of B Trigger Sensitivity, Slope Center, and Level Center adjustments.

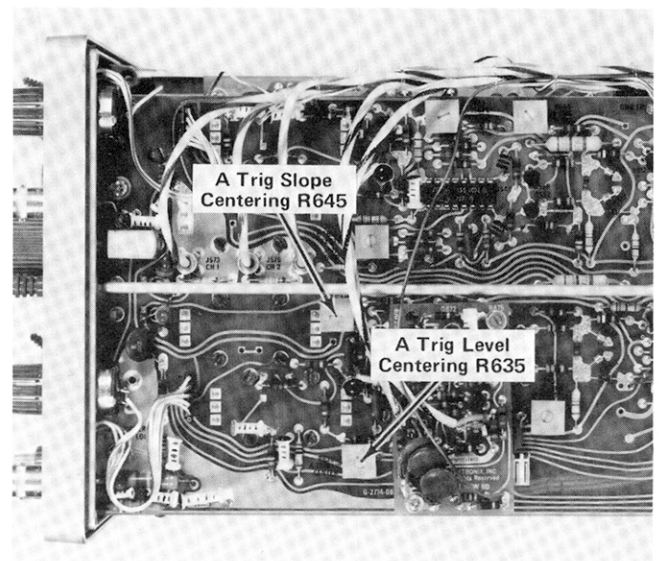

Fig. 5-26. Location of A Trigger Slope Center and Level Center adjustments.

c. Position the display to the vertical center of the graticule viewing area.

d. CHECK—That a stable display can be obtained on both the + and – slopes of the displayed waveform by rotating the A SLOPE control.

e. ADJUST—Normal Trigger DC Balance adjustment, R340, (see Fig. 5-27) to obtain a stable display on both the + and – slopes of the displayed waveform.

f. Set the A SOURCE switch to CH 1.

g. CHECK—For a stable display on both the + and – slopes of the displayed waveform.

h. ADJUST—CH 1 Trigger DC Balance adjustment, R155, (see Fig. 5-27) to obtain a stable display on both the + and – slopes of the displayed waveform.

i. Set the VERT MODE switch to CH 2.

j. Adjust the CH 2 VOLTS/DIV switch to obtain a 0.3 division display.

k. Position the display to the vertical center of the graticule viewing area.

l. Set the A SOURCE switch to CH 2.

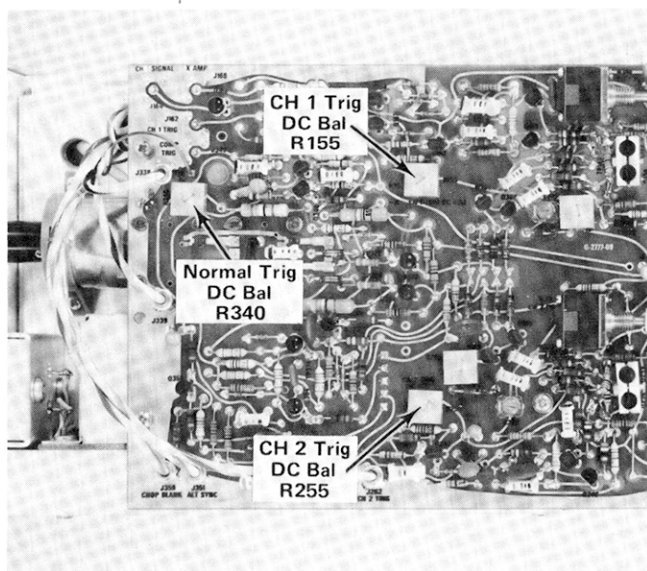

Fig. 5-27. Location of Trigger DC Level adjustments.

m. CHECK—For a stable display on both the + and – slopes of the displayed waveform.

n. ADJUST—CH 2 Trigger DC Balance adjustment, R255, (see Fig. 5-27) to obtain a stable display on both the + and – slopes of the displayed waveform.

44. Check B Trigger DC Levels

a. Set the HORIZ DISPLAY switch to B DLY'D, the B LEVEL control to 0, the B SOURCE switch to NORM, and the B COUPLING switch to DC.

b. CHECK—That a stable display can be obtained on both the + and – slopes of the displayed waveform in the NORM and CH 2 positions of the B SOURCE switch.

c. Set the VERT MODE switch to CH 1.

d. Adjust the CH 1 VOLTS/DIV switch to obtain a 0.3 division display.

e. Position the display to the vertical center of the graticule viewing area.

f. CHECK—That a stable display can be obtained on both the + and – slopes of the displayed waveform in the NORM and CH 1 positions of the B SOURCE switch.

45. Check B Internal 25 Megahertz Triggering

a. Set the DELAY TIME POSITION dial fully counter-clockwise, both TIME/DIV switches to $0.05\mu\text{s}$, both VOLTS/DIV switches to 10 mV, and both SOURCE switches to NORM.

b. Adjust the Medium-Frequency signal generator to maintain a 0.3 division display of a 25 megahertz signal throughout this step.

c. Rotate the B SLOPE switch between + and –.

d. CHECK—A stable display can be obtained on both the + and – slopes of the displayed waveform in the AC, LF REJ, and DC positions of the B COUPLING switch (adjust the B LEVEL control).

e. Set the B SOURCE switch to CH 1.

Calibration—465

- f. Repeat steps 45-c and 45-d.
- g. Set the VERT MODE switch to CH 2.
- h. CHECK—That a stable display cannot be obtained with the B SOURCE switch set to CH 1.
- i. Repeat steps 45-c and 45-d for NORM and CH 2 positions of the B SOURCE switch.

46. Check A Internal 25 Megahertz Triggering

- a. Set the HORIZ DISPLAY switch to A.
- b. Adjust the Medium-Frequency signal generator to maintain a 0.3 division display of a 25 megahertz signal throughout this step.
- c. Rotate the A SLOPE switch between + and —.
- d. CHECK—A stable display can be obtained on both the + and — slopes of the displayed waveform in the AC, LF REJ, and DC positions of the A COUPLING switch (adjust the A LEVEL control).
- e. Set the A SOURCE switch to CH 1.
- f. Repeat steps 46-c and 46-d.
- g. Set the VERT MODE switch to CH 1.
- h. CHECK—That a stable display cannot be obtained with the A SOURCE switch set to CH 2.
- i. Repeat steps 46-c and 46-d for NORM and CH 1 positions of the A SOURCE switch.

47. Check A External 25 Megahertz Triggering

- a. Set the HORIZ DISPLAY switch to A, the A SOURCE switch to EXT, the B SOURCE switch to NORM, and the CH 1 VOLTS/DIV switch to 20 mV.
- b. Adjust the Medium-Frequency signal generator for a 5 division display.

c. Add a X2 BNC attenuator to the test setup between the X10 BNC attenuator and the 50 Ω BNC termination.

d. CHECK—That a stable display can be obtained, by adjusting the A LEVEL control, in both the + and — slopes of the displayed waveform in the AC and DC positions of the A COUPLING switch.

e. Remove the X2 BNC attenuator from the External Trigger signal test setup.

f. CHECK—That a stable display can be obtained, by adjusting the A LEVEL control, in both the + and — slopes of the displayed waveform in the LF REJ position of the A COUPLING switch.

g. Replace the X2 BNC attenuator to the test setup and set the A SOURCE switch to EXT \div 10.

h. Remove the X10 BNC attenuator from the test setup.

i. CHECK—That a stable display can be obtained, by adjusting the A LEVEL control, in both the + and — slopes of the displayed waveform in the AC and DC positions of the A COUPLING switch.

j. Remove the X2 BNC attenuator from the test setup.

k. CHECK—That a stable display can be obtained, by adjusting the A LEVEL control, in both the + and — slopes of the displayed waveform in the LF REJ position of the A COUPLING switch.

l. Replace both the X10 and X2 BNC attenuators to the test setup.

48. Check B External 25 Megahertz Triggering

- a. Set the HORIZ DISPLAY switch to B DLY'D, the B SOURCE switch to EXT, and the A SOURCE switch to NORM.
- b. Adjust the Medium-Frequency signal generator for a five division display.
- c. CHECK—That a stable display can be obtained, by adjusting the LEVEL controls, in both the + and — slopes of the displayed waveform in the AC and DC positions of the B COUPLING switch.

d. Remove the X2 BNC attenuator from the test setup.

e. CHECK—That a stable display can be obtained, by adjusting the LEVEL controls, in both the + and – slopes of the displayed waveform in the LF REJ position of the B COUPLING switch.

f. Replace the X2 BNC attenuator to the test setup.

49. Check A and B External 100 Megahertz Triggering

a. Set the A TIME/DIV switch to $50\ \mu\text{s}$, the TRIG MODE to AUTO, the X10 MAG button in, both VOLTS/DIV switches to 50 mV, the VERT MODE switch to CH 1, and the A SOURCE switch to EXT $\div 10$.

b. Adjust the Medium-Frequency signal generator for a three-division display of a 25-megahertz reference signal.

c. Set the A TIME/DIV switch to $0.05\ \mu\text{s}$.

d. Adjust the signal generator for a 100 megahertz output frequency.

e. CHECK—That a stable display, with no more than 0.1 division of jitter, can be obtained in both the + and – slopes of the displayed waveform, by adjusting the A LEVEL control, in the AC and DC positions of the A COUPLING switch.

f. Remove the X2 BNC attenuator.

g. CHECK—That a stable display, with no more than 0.1 division of jitter, can be obtained in both the + and – slopes of the displayed waveform, by adjusting the A LEVEL control, in the LF REJ position of the A COUPLING switch.

h. Replace the X10 and X2 BNC attenuators to the test setup.

i. Set the A SOURCE switch to EXT.

j. Repeat the 100-megahertz triggering check procedure, steps 49-e through 49-g.

k. Replace the X2 BNC attenuator to the test setup.

l. Set the HORIZ DISPLAY switch to B DLY'D, the B SOURCE switch to EXT, and the A SOURCE switch to NORM.

m. CHECK—That a stable display, with no more than 0.1 division of jitter, can be obtained in both the + and – slopes of the displayed waveform, by adjusting both LEVEL controls, in the AC and DC positions of the B COUPLING switch.

n. Remove the X2 BNC attenuator.

o. CHECK—That a stable display, with no more than 0.1 division of jitter, can be obtained in both the + and – slopes of the displayed waveform, by adjusting both LEVEL controls, in the LF REJ position of the B COUPLING switch.

50. Check B Internal 100 Megahertz Triggering

a. Set the B SOURCE switch to NORM and both VOLTS/DIV switches to 10 mV.

b. Adjust the Medium-Frequency signal generator for a 1.5-division display of 100-megahertz signal.

c. CHECK—That a stable display, with no more than 0.1 division of jitter, can be obtained in both the + and – slopes of the displayed waveform, by adjusting both LEVEL controls, in the AC, LF REJ, and DC positions of the B COUPLING switch.

d. Set the B SOURCE switch to CH 1.

e. Repeat step 50-c.

f. Set the B SOURCE switch to CH 2.

g. CHECK—That a stable display cannot be obtained in any position of the B COUPLING switch.

h. Set the VERT MODE switch to CH 2.

i. Repeat step 50-c.

j. Set the B SOURCE switch to NORM.

k. Repeat step 50-c.

l. Set the B SOURCE switch to CH 1.

m. Repeat step 50-g.

51. Check A Internal 100 Megahertz Triggering

- a. Set the HORIZ DISPLAY switch to A.
- b. CHECK—That a stable display, with no more than 0.1 division of jitter, can be obtained in both the + and – slopes of the displayed waveform, by adjusting the A LEVEL control, in the AC, LF REJ, and DC positions of the A COUPLING switch.
- c. Set the A SOURCE switch to CH 2.
- d. Repeat step 51-b.
- e. Set the A SOURCE switch to CH 1.
- f. CHECK—That a stable display cannot be obtained in any position of the A COUPLING switch.
- g. Set the VERT MODE switch to CH 1.
- h. Repeat step 51-b.
- i. Set the A SOURCE switch to NORM.
- j. Repeat step 51-b.
- k. Set the A SOURCE switch to CH 2.
- l. Repeat step 51-f.
- m. Disconnect the test setup.

52. Check A and B HF REJ Triggering

- a. Set the HORIZ DISPLAY to A, the TIME/DIV switches to $5\mu\text{s}$, the TRIG MODE switch to AUTO, both COUPLING switches to HF REJ, and both SOURCE switches to NORM.
- b. Connect the output of the Medium-Frequency Constant-Amplitude Signal Generator (Type 191) to the CH 1 input via a $50\ \Omega$ 5 ns GR cable, a $50\ \Omega$ Signal Pickoff Unit (Type CT-3) thru output, a GR-to-BNC adapter and an 18-inch $50\ \Omega$ BNC cable.

c. Connect the 10% output of the Signal Pickoff Unit to the A External Trigger Input via an 18-inch $50\ \Omega$ BNC cable and a $50\ \Omega$ BNC termination.

d. Adjust the Medium-Frequency signal generator for a 0.5-volt output and adjust the CH 1 VOLTS/DIV switch for a 0.3-division display of a 50-kilohertz signal.

e. CHECK—That a stable display can be obtained in both the + and – slopes of the displayed waveform, in all positions of the A COUPLING switch, by adjusting the A LEVEL control.

f. Increase the output of the Medium-Frequency signal generator to 1 megahertz.

g. CHECK—That a stable display cannot be obtained in the HF REJ position of the A COUPLING switch.

h. Set the A SOURCE switch to EXT.

i. CHECK—That a stable display cannot be obtained in the HF REJ position of the A COUPLING switch.

j. Reduce the Medium-Frequency signal generator output frequency to 50 kilohertz.

k. CHECK—That a stable display can be obtained in both the + and – slopes of the displayed waveform, in all positions of the A COUPLING switch, by adjusting the A LEVEL control.

l. Move the External Trigger signal to the B External Trigger input.

m. CHECK—That a stable display can be obtained in both the + and – slopes of the displayed waveform, in all positions of the B COUPLING switch, by adjusting the LEVEL controls.

n. Increase the output of the Medium-Frequency signal generator to 1 meaghertz.

o. CHECK—That a stable display cannot be obtained in the HF REJ position of the B COUPLING switch.

p. Set the B SOURCE switch to EXT.

q. CHECK—That a stable display cannot be obtained in the HF REJ position of the B COUPLING switch.

r. Reduce the Medium-Frequency signal generator output frequency to 50 kilohertz.

s. CHECK—That a stable display can be obtained in both the + and – slopes of the displayed waveform, in all positions of the B COUPLING switch, by adjusting the LEVEL controls.

t. Disconnect the test setup.

53. Check B 60 Hertz and LF REJ Triggering

a. Set the B TIME/DIV switch to 5 ms, the HORIZ DISPLAY switch to B DLY'D, both SOURCE switches to NORM, and both VOLTS/DIV switches to 0.1 V.

b. Connect the Low-Frequency Sine-Wave Generator (General Radio 1310-A) to the CH 1 input via a 42-inch 50 Ω BNC cable, a BNC-T connector, and an 18-inch 50 Ω BNC cable. Connect the other side of the BNC-T connector to the B External Trigger input via a X10 BNC attenuator and a 50 Ω BNC termination.

c. Adjust the Sine-Wave Generator for a 0.3-division display of a 60-hertz signal.

d. CHECK—That a stable display can be obtained in both the + and – slopes of the displayed waveform, in the AC, HF REJ, and DC positions of the B COUPLING switch, by adjusting the LEVEL controls.

e. CHECK—That a stable display cannot be obtained in the LF REJ position of the B COUPLING switch.

f. Set the B SOURCE switch to CH 1.

g. CHECK—That a stable display can be obtained in both the + and – slopes of the displayed waveform, in the AC, HF REJ, and DC positions of the B COUPLING switch, by adjusting the LEVEL controls.

h. CHECK—That a stable display cannot be obtained in the LF REJ position of the B COUPLING switch.

i. Set the B SOURCE switch to CH 2.

j. CHECK—That a stable display cannot be obtained in any position of the B COUPLING switch.

k. Move the test signal from CH 1 to the CH 2 input.

l. Adjust the Sine-Wave Generator for a 0.3-division display of a 60-hertz signal.

m. CHECK—That a stable display can be obtained in both the + and – slopes of the displayed waveform, in the AC, HF REJ, and DC positions of the B COUPLING switch, by adjusting the LEVEL controls.

n. CHECK—That a stable display cannot be obtained in the LF REJ position of the B COUPLING switch.

o. Set the B SOURCE switch to EXT.

p. CHECK—That a stable display can be obtained in both the + and – slopes of the displayed waveform, in the AC, HF REJ, and DC positions of the B COUPLING switch, by adjusting the LEVEL controls.

q. CHECK—That a stable display cannot be obtained in the LF REJ position of the B COUPLING switch.

54. Check A 60 Hertz and LF REJ Triggering

a. Set the HORIZ DISPLAY switch to A.

b. Move the signal from the B External Trigger input to the A External Trigger input.

c. CHECK—That a stable display can be obtained in both the + and – slopes of the displayed waveform, in the AC, HF REJ, and DC positions of the A COUPLING switch, by adjusting the A LEVEL control.

d. CHECK—That a stable display cannot be obtained in the LF REJ position of the A COUPLING switch.

e. Set the A SOURCE switch to CH 2.

f. CHECK—That a stable display can be obtained in both the + and – slopes of the displayed waveform, in the AC, HF REJ, and DC positions of the A COUPLING switch, by adjusting the A LEVEL control.

Calibration—465

- g. Set the A SOURCE switch to CH 1.
- h. CHECK—That a stable display cannot be obtained in any position of the A COUPLING switch.
- i. Move the test signal from CH 2 to the CH 1 input.
- j. Adjust the Sine-Wave Generator for a 0.3-division display of a 60-hertz signal.
- k. CHECK—That a stable display can be obtained in both the + and – slopes of the displayed waveform, in the AC, HF REJ, and DC positions of the A COUPLING switch, by adjusting the A LEVEL control.
- l. CHECK—That a stable display cannot be obtained in the LF REJ position of the A COUPLING switch.
- m. Set the A SOURCE switch to EXT.
- n. CHECK—That a stable display can be obtained in both the + and – slopes of the displayed waveform, in the AC, HF REJ, and DC positions of the A COUPLING switch, by adjusting the A LEVEL control.
- o. CHECK—That a stable display cannot be obtained in the LF REJ position of the A COUPLING switch.
- p. Disconnect the test setup.
- e. CHECK—Display is not triggered at either extreme of rotation.
- f. Set the A SLOPE switch to –.
- g. CHECK—That the display can be triggered at any point along the negative slope of the waveform when rotating the A LEVEL control throughout its range.
- h. CHECK—Display is not triggered at either extreme of rotation.
- i. Set the CH 1 VOLTS/DIV switch to 10 V and the A SOURCE switch to EXT \div 10.
- j. Adjust the Sine-Wave Generator for a four-division display of a 1-kilohertz signal.
- k. CHECK—That the display can be triggered at any point along the negative slope of the waveform when rotating the A LEVEL control throughout its range.
- l. CHECK—Display is not triggered at either extreme of rotation.
- m. Set the A SLOPE switch to +.
- n. CHECK—That the display can be triggered at any point along the positive slope of the waveform when rotating the A LEVEL control throughout its range.
- o. CHECK—Display is not triggered at either extreme of rotation.

55. Check A LEVEL Control External Range

- a. Set both SOURCE switches to EXT, the CH 1 VOLTS/DIV switch to 1 V, and the A SLOPE switch to +.
- b. Connect the output of the Low-Frequency Sine-Wave Generator (General Radio 1310-A) to the CH 1 input and the A External Trigger input through a BNC-T Connector and two 42-inch 50 Ω BNC cables.
- c. Adjust the Sine-Wave Generator for a four-division display of a 1-kilohertz signal.
- d. CHECK—That the display can be triggered at any point along the positive slope of the waveform when rotating the A LEVEL control throughout its range.

56. Check B LEVEL Control External Range

- a. Set the HORIZ DISPLAY switch to B DLY'D.
- b. Move the External Trigger signal to the B External Trigger input.
- c. Set the A SOURCE switch to NORM, the B SLOPE switch to +, and the CH 1 VOLTS/DIV switch to 1 V.
- d. Adjust the Sine-Wave Generator for a four-division display of a 1-kilohertz signal.

e. CHECK—That the display can be triggered at any point along the positive slope of the waveform when rotating the B LEVEL control throughout its range.

f. CHECK—Display is not triggered at either extreme of rotation.

g. Set the B SLOPE switch to —.

h. CHECK—That the display can be triggered at any point along the negative slope of the waveform when rotating the B LEVEL control throughout its range.

i. CHECK—Display is not triggered at either extreme of rotation.

57. CHECK Single Sweep Operation

a. Set the HORIZ DISPLAY switch to A, and the A COUPLING switch to AC.

b. Adjust the Low-Frequency Sine-Wave Generator for a 50-kilohertz signal output.

c. Adjust the A LEVEL control for a triggered display.

d. Disconnect the test signal from the CH 1 input.

e. Press the SINGL SWP button of the TRIG MODE switch.

f. CHECK—READY light comes on when SINGL SWP button is pressed and remains on until the test signal is re-applied.

g. Reconnect the test signal to the CH 1 input.

h. CHECK—READY light is extinguished.

i. Press the SINGL SWP button.

j. CHECK—That a single-sweep display (one sweep only) is presented.

58. Check A Normal Mode Operation

a. Set the A SOURCE switch to NORM, and the TRIG MODE switch to AUTO.

b. Adjust the Sine-Wave Generator for a 50-kilohertz signal.

c. Adjust the A LEVEL control for a triggered display.

d. Switch the TRIG MODE switch to NORM.

e. CHECK—For a stable display.

f. Remove the test signal from the CH 1 input.

g. CHECK—For no trace in the absence of an adequate trigger signal.

59. Check LINE Triggering

a. Set the HORIZ DISPLAY switch to A, the TRIG MODE switch to AUTO, the A SOURCE switch to LINE, and the A COUPLING switch to AC.

b. Connect a X10 probe from the CH 1 input to a line voltage source.

c. Set the CH 1 VOLTS/DIV switch to display four divisions of deflection.

d. Rotate the A SLOPE switch between + and —.

e. CHECK—Sweep starts on the slope selected by the A SLOPE switch.

f. Disconnect the test setup.

60. Check Automatic Recovery Time

a. Set the A TIME/DIV switch to 50 ms, the A SLOPE switch to +, and the A SOURCE switch to NORM.

b. Connect 50 ms time marks from the Time Mark Generator (Type 2901) to the CH 1 input via a 42-inch 50 Ω BNC cable and a 50 Ω BNC termination.

c. CHECK—That a stable display can be obtained by adjusting the A LEVEL control. Time marker must be at the start of the sweep.

d. Disconnect the test setup.

61. Adjust Trigger View Centering

a. Set the VERT MODE switch to CH 1, CH 1 INPUT COUPLING switch to DC, the CH 1 VOLTS/DIV switch to 10 mV, the A COUPLING switch to DC, the A SOURCE switch to EXT, the A SLOPE switch to +, and the A LEVEL control to 0.

b. Push the TRIG VIEW button and hold it in.

c. CHECK—That the trace is within 1 division of the center horizontal graticule line.

d. ADJUST—Trigger View Centering adjustment, R675, (see Fig. 5-28) so that the trace is at the center horizontal line.

e. Release the TRIG VIEW button.

f. Disconnect the test setup.

62. Check Trigger View Deflection Factor

a. Connect the output of the Standard Amplitude Calibrator to the A External Trigger input via a 42-inch 50 Ω BNC cable.

b. Adjust the Standard Amplitude Calibrator for a 200 mV square-wave output.

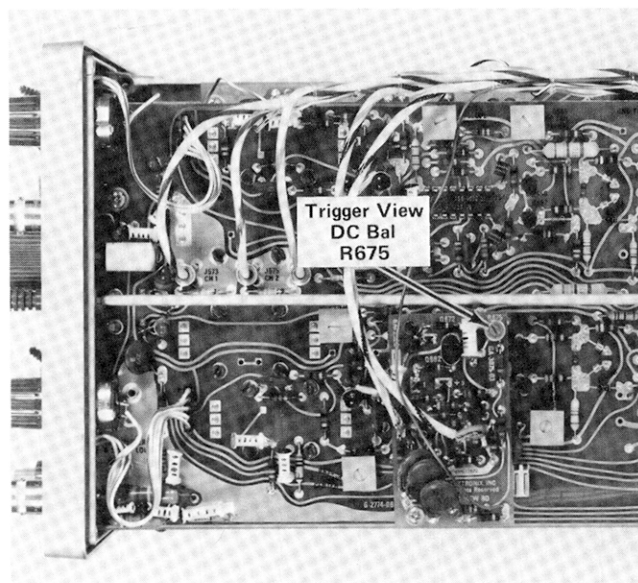

Fig. 5-28. Location of Trigger View Centering adjustment.

c. Push the TRIG VIEW button and hold in.

d. CHECK—For 3.2 to 4.8 divisions of display.

e. Release the TRIG VIEW button.

f. Disconnect the test setup.

HORIZONTAL SYSTEM CALIBRATION

Equipment Required

- | | |
|---|----------------------------------|
| 1. Medium-Frequency Constant-Amplitude Signal Generator (Type 191). | 5. Dual-Input Coupler |
| 2. Test Oscilloscope | 6. 42-inch 50 Ω BNC Cable |
| 3. Time Mark Generator | 7. 50 Ω BNC Termination |
| 4. Standard Amplitude Calibrator | 8. Three-Inch Screwdriver |
| | 9. Low-Capacitance Screwdriver |

Control Settings

Preset instrument controls to the settings given under Preliminary Control Settings except as follows:

| | |
|---------------------|--------------------|
| A TIME/DIV | 1 ms |
| B TIME/DIV | 5 μ s |
| B TRIGGER | |
| SOURCE | STARTS AFTER DELAY |
| HORIZ DISPLAY | A INTEN |
| DELAY-TIME POSITION | 1.00 |

63. Adjust Sweep Start and A Sweep Calibration

a. Connect 1 ms time marks to the CH 1 input from the Time Mark Generator via a 42-inch 50 Ω BNC cable and a 50 Ω BNC termination.

b. CHECK—Intensified portion of the sweep begins at the second time marker.

c. ADJUST—Sweep Start adjustment, R1115, (see Fig. 5-29) so the intensified portion of the sweep begins at the start of the second time marker.

d. Set the DELAY TIME POSITION dial to 9.00.

e. CHECK—Intensified portion of the sweep begins at the tenth time marker.

f. ADJUST—A Sweep Calibration adjustment, R1145, (see Fig. 5-29) so the intensified portion of the sweep begins at the start of the tenth time marker.

g. Set the HORIZ DISPLAY switch to B DLY'D.

h. Set the DELAY TIME POSITION dial to 1.00.

i. CHECK—Displayed pulse starts at the beginning of the sweep.

j. ADJUST—Sweep Start adjustment, R1115, so the displayed pulse starts at the beginning of the sweep.

k. Set the DELAY TIME POSITION dial to 9.00.

l. CHECK—Displayed pulse starts at the beginning of the sweep.

m. ADJUST—A Sweep Calibration adjustment, R1145, so the displayed pulse starts at the beginning of the sweep.

n. INTERACTION—Between Sweep Start and A Sweep Cal adjustment. Repeat both for no visible interaction.

64. Check Differential Time Accuracy

a. Set the DELAY TIME POSITION dial to position the tenth time marker to the beginning of the sweep.

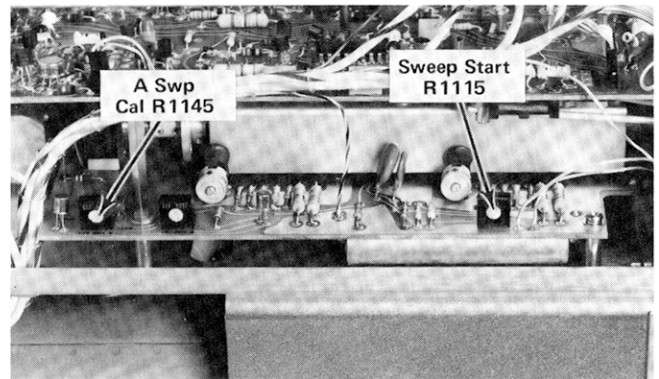

Fig. 5-29. Location of Sweep Start and A Sweep Cal adjustments.

Calibration—465

b. Note the reading on the DELAY TIME POSITION dial.

c. Adjust the DELAY TIME POSITION dial so the ninth time marker is at the beginning of the sweep.

d. CHECK—DELAY TIME POSITION dial for a reading one division less, within 0.01 division from $+15^{\circ}\text{C}$ to $+35^{\circ}\text{C}$; one division less, within 0.03 division from -15°C to $+55^{\circ}\text{C}$, than the reading noted in step 64-b.

e. Rotate the DELAY TIME POSITION dial to position each successive time marker to the beginning of the sweep.

f. CHECK—DELAY TIME POSITION dial for a reading of one division less, within 0.01 division from $+15^{\circ}\text{C}$ to $+35^{\circ}\text{C}$; one division less, within 0.03 division from -15°C to $+55^{\circ}\text{C}$, than the adjacent time marker.

65. Adjust Horizontal Amplifier Gain

a. Set the HORIZ DISPLAY switch to A, both TIME/DIV switches to 1 ms, and the VERT MODE switch to CH 1.

b. Select 1 ms time marks from the Time Mark Generator.

c. ADJUST—X1 Gain adjustment, R1237, (see Fig. 5-30) for exactly one time marker/division.

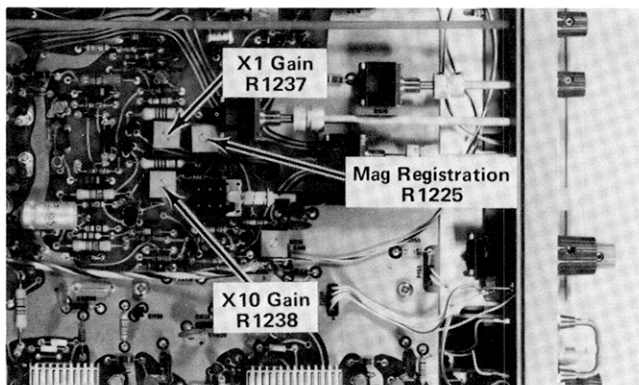

Fig. 5-30. Location of Horizontal Gain and Magnifier Registration adjustments.

d. Select 0.1 ms time marks from the Time Mark Generator.

e. Push the X10 MAG button.

f. CHECK—X10 MAG light is on when the X10 MAG button is in.

g. ADJUST—X10 Gain adjustment, R1238, (see Fig. 5-30) for exactly one time marker/division.

66. Check Sweep Linearity

a. CHECK—Sweep accuracy over any 2 division portion of 10 division sweep to be within 0.1 division.

b. Release the X10 MAG.

c. Select 1 ms time marks from the Time Mark Generator.

d. CHECK—Linearity over any 2 divisions of the sweep to be within 0.1 division of accurate timing.

67. Adjust Magnifier Registration

a. Push the X10 MAG button in.

b. Select 5 ms time markers from the Time Mark Generator.

c. Position the middle time marker to the center vertical graticule line.

d. Release the X10 MAG.

e. CHECK—Middle time marker is within 0.2 division of the center vertical graticule line.

f. ADJUST—Magnifier Registration adjustment, R1225, (see Fig. 5-30) to position the middle time marker to the center vertical graticule line.

g. CAL AID—Repeat the above procedure until no shift occurs between positions of the X10 MAG switch.

68. Adjust B Sweep Calibration

a. Set the DELAY TIME POSITION dial fully counter-clockwise; the HORIZ DISPLAY switch to B DLY'D; B TIME/DIV switch to 1 ms; B TRIGGER; COUPLING switch to AC, SOURCE switch to NORM.

b. Select 1 ms time marks from the Time Mark Generator.

c. CHECK—CRT display for 1 time marker/division.

d. ADJUST—B Sweep Calibration adjustment, R1175, (see Fig. 5-31) for 1 time marker/division.

69. Check Sweep Length

a. Set the A TIME/DIV switch to 1 ms, the B TIME/DIV switch to 1 ms, and the HORIZ DISPLAY switch to A.

b. Select 1 ms and 0.1 ms time marks from the Time Mark Generator.

c. CHECK—A sweep length is 11 divisions, within 0.5 division.

70. Check VAR TIME/DIV Range

a. Set the A TIME/DIV switch to 2 ms.

b. Select 5 ms time marks from the Time Mark Generator.

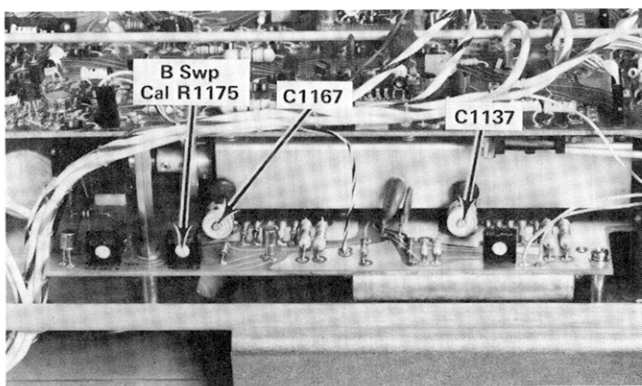

Fig. 5-31. Location of High Speed Timing and B Sweep Cal adjustments.

c. CHECK—At least 1 time marker/division can be obtained by adjusting the VAR TIME/DIV control.

d. CHECK—That the UNCAL light comes on when the VAR TIME/DIV control is out of the detent position.

e. Return the VAR TIME/DIV control to the detent position.

71. Check Horizontal POSITION Control Range

a. Set the horizontal FINE position control to midrange and the A TIME/DIV switch to 2 ms.

b. Turn the horizontal POSITION control fully clockwise.

c. CHECK—Start of sweep is to the right of the center vertical graticule line.

d. Turn the horizontal POSITION control fully counter-clockwise.

e. CHECK—End of sweep is to the left of the center vertical graticule line.

f. Rotate the horizontal FINE position control.

g. CHECK—That the FINE position control will position the sweep between one and two divisions.

72. Adjust A TIME/DIV High Speed Timing

a. Set the DELAY TIME POSITION dial to 1.50, the B SOURCE switch to STARTS AFTER DELAY, the A TIME/DIV switch to 0.5 μ s, and the B TIME/DIV switch to 0.05 μ s.

b. Select 0.5 μ s time marks from the Time Mark Generator.

c. CHECK—CRT display for one time marker/division.

d. ADJUST—A High Speed Timing adjustment, C1137, (see Fig. 5-31) with the low-capacitance screwdriver, for one time marker/division.

- e. Switch the HORIZ DISPLAY switch to B DLY'D.
- f. Set the horizontal POSITION control so the displayed time marker crosses the center vertical graticule line.
- g. Set the DELAY TIME POSITION dial to 8.50.
- h. CHECK—That the displayed time marker crosses the center vertical graticule line.
- i. ADJUST—A High Speed Timing adjustment, C1137, so the displayed time marker crosses the center vertical graticule line.

j. INTERACTION—There is interaction, when adjusting C1137, between the two positions of the DELAY-TIME POSITION dial. Compromise the adjustments as necessary to achieve optimum timing.

73. Adjust B TIME/DIV High Speed Timing

a. Set the DELAY TIME POSITION dial fully counter-clockwise, the HORIZ DISPLAY switch to B DLY'D, B SOURCE switch to NORM, A TIME/DIV switch to 1 μ s, and the B TIME/DIV switch to 0.5 μ s.

b. Select 0.5 μ s time marks from the Time Mark Generator.

c. Adjust the A and B LEVEL controls for a stable display.

d. CHECK—CRT display for one time marker/division.

e. ADJUST—B High Speed Timing adjustment, C1167, (see Fig. 5-31) for one time marker/division.

74. Check A and B TIME/DIV Accuracy

a. CHECK—Using the B TIME/DIV switch and the Time Mark Generator settings given in Table 5-7, check B sweep timing, within 0.2 division, over the first ten divisions of the display.

b. Set the HORIZ DISPLAY to A.

c. CHECK—Using the A TIME/DIV switch and the Time Mark Generator settings given in Table 5-7, check A sweep timing, within 0.2 division, over the first ten divisions of the display.

TABLE 5-7
A and B Timing Accuracy

| A and B TIME/DIV Switch Setting | Time-Mark Generator Output | CRT Display (Markers/Division) |
|---------------------------------|----------------------------|--------------------------------|
| .05 μ s | 50 nanosecond | 1 |
| .1 μ s | 0.1 microsecond | 1 |
| .2 μ s | 0.1 microsecond | 2 |
| .5 μ s | 0.5 microsecond | 1 |
| 1 μ s | 1 microsecond | 1 |
| 2 μ s | 1 microsecond | 2 |
| 5 μ s | 5 microsecond | 1 |
| 10 μ s | 10 microsecond | 1 |
| 20 μ s | 10 microsecond | 2 |
| 50 μ s | 50 microsecond | 1 |
| .1 ms | 0.1 millisecond | 1 |
| .2 ms | 0.1 millisecond | 2 |
| .5 ms | 0.5 millisecond | 1 |
| 1 ms | 1 millisecond | 1 |
| 2 ms | 1 millisecond | 2 |
| 5 ms | 5 millisecond | 1 |
| 10 ms | 10 millisecond | 1 |
| 20 ms | 10 millisecond | 2 |
| 50 ms | 50 millisecond | 1 |
| A SWEEP ONLY | | |
| .1 s | 0.1 second | 1 |
| .2 s | 0.1 second | 2 |
| .5 s | 0.5 second | 1 |

75. Adjust High Speed Magnified Timing

a. Set the X10 MAG on, the Horizontal POSITION control to midrange, and the A TIME/DIV switch to 0.05 μ s.

b. Select 10 ns sine-wave output from the Time Mark Generator.

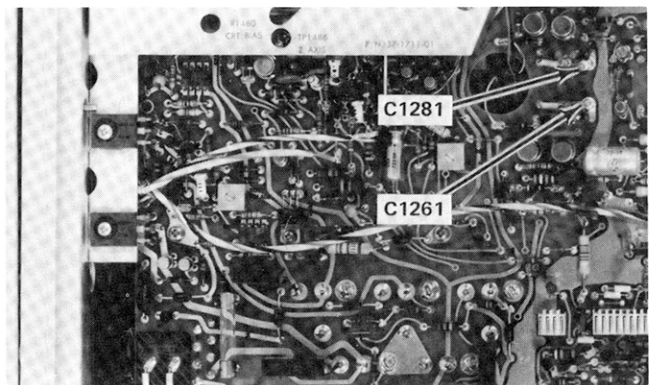

Fig. 5-32. Location of Magnified Timing adjustment.

c. CHECK—CRT display for one cycle/two divisions, within 0.3 division over the full ten horizontal graticule divisions. Disregard the first and last ten divisions of sweep length. See Table 5-8.

d. ADJUST—Magnifier Timing adjustments, C1261 and C1281 (see Fig. 5-32), with the low-capacitance screwdriver for one cycle/two divisions. Disregard the first and last ten divisions of sweep length.

b. Set the HORIZ DISPLAY switch to B DLY'D.

c. CHECK—Using the B TIME/DIV switch and the Time Mark Generator settings given in Table 5-8, check B magnified sweep timing, within 0.3 division over the center ten divisions of the magnified display. Note the portions of the total magnified sweep length to be excluded from the measurement.

d. Release the X10 MAG.

76. Check A and B Magnified Timing Accuracy

a. CHECK—Using the A TIME/DIV switch and the Time Mark Generator settings given in Table 5-8, check A magnified sweep timing, within 0.3 division over the center ten divisions of the magnified display. Note the portions of the total magnified sweep length to be excluded from the measurement.

77. Check Delay Time Accuracy

a. Set the B SOURCE switch to STARTS AFTER DELAY, the A TIME/DIV switch to 0.2 μs, and the B TIME/DIV switch to 0.05 μs.

b. CHECK—Using the A TIME/DIV switch, B TIME/DIV switch and the Time Mark Generator settings given in Table 5-9, check delayed sweep accuracy is within the given tolerance. First set the DELAY TIME POSITION dial to 1.00 and rotate the dial until the sweep starts at the top of

TABLE 5-8
A and B Magnified Accuracy

| A and B TIME/DIV Switch Setting | Time-Mark Generator Output | CRT Display (Markers/Division) | Portions of total magnified sweep length to exclude from measurement |
|---------------------------------|----------------------------|--------------------------------|--|
| .05 μs | 5 nanosecond | 1 | First and last 10 divisions |
| .1 μs | 10 nanosecond | 1 | First and last 5 divisions |
| .2 μs | 10 nanosecond | 2 | First and last 2 1/2 divisions |
| .5 μs | 50 nanosecond | 1 | |
| 1 μs | 0.1 microsecond | 1 | |
| 2 μs | 0.1 microsecond | 2 | |
| 5 μs | 0.5 microsecond | 1 | |
| 10 μs | 1 microsecond | 1 | |
| 20 μs | 1 microsecond | 2 | |
| 50 μs | 5 microsecond | 1 | |
| .1 ms | 10 microsecond | 1 | |
| .2 ms | 10 microsecond | 2 | |
| .5 ms | 50 microsecond | 1 | |
| 1 ms | 0.1 millisecond | 1 | |
| 2 ms | 0.1 millisecond | 2 | |
| 5 ms | 0.5 millisecond | 1 | |
| 10 ms | 1 millisecond | 1 | |
| 20 ms | 1 millisecond | 2 | |
| 50 ms | 5 millisecond | 1 | |
| A SWEEP ONLY | | | |
| .1 s | 10 millisecond | 1 | |
| .2 s | 10 millisecond | 2 | |
| .5 s | 50 millisecond | 1 | |

TABLE 5-9
Delayed Sweep Accuracy

| A TIME/DIV Switch Setting | B TIME/DIV Switch Setting | Time-Mark Generator Output | Allowable Error for Given Accuracy |
|---------------------------|---------------------------|----------------------------|------------------------------------|
| .2 μs | .05 μs | .1 microsecond | ±8 minor dial divisions |
| .5 μs | .05 μs | .5 microsecond | |
| 1 μs | .1 μs | 1 microsecond | |
| 2 μs | .1 μs | 1 microsecond | |
| 5 μs | .1 μs | 5 microsecond | |
| 10 μs | 1 μs | 10 microsecond | |
| 20 μs | 1 μs | 10 microsecond | |
| 50 μs | 1 μs | 50 microsecond | |
| .1 ms | 10 μs | .1 millisecond | |
| .2 ms | 10 μs | .1 millisecond | |
| .5 ms | 10 μs | .5 millisecond | |
| 1 ms | .1 ms | 1 millisecond | |
| 2 ms | .1 ms | 1 millisecond | |
| 5 ms | .1 ms | 5 millisecond | |
| 10 ms | 1 ms | 10 millisecond | |
| 20 ms | 1 ms | 10 millisecond | |
| 50 ms | 1 ms | 50 millisecond | |
| .1 s | 10 ms | .1 second | |
| .2 s | 10 ms | .1 second | |
| .5 s | 10 ms | .5 second | |

Calibration—465

the second time marker. Note the control setting and then set the dial to 9.00 and rotate it slightly until the sweep starts at the top of the tenth time marker. DELAY TIME POSITION dial setting must be 8.00 divisions higher, ± 0.08 divisions.

NOTE

Sweep will start at top of the third time marker at 1.00 and at the top of the nineteenth time marker at 9.00 for sweep rates which are multiples of 2 (e.g., 2 μ s, 20 μ s, 0.2 ms, etc.). If in doubt as to the correct setting of the DELAY TIME POSITION dial, set the HORIZ DISPLAY switch to A INTEN and check which marker is intensified.

78. Check Delay Time Jitter

a. Set the DELAY TIME POSITION dial to 1.00, the HORIZ DISPLAY switch to B DLY'D, the A TIME/DIV switch to 1 ms, and the B TIME/DIV switch to 1 μ s.

b. Position the time marker near the center of the display area with the DELAY TIME POSITION dial.

c. CHECK—Jitter on the leading edge of the time marker should not exceed 0.2 division (0.5 division if the instrument is being operated on a 50 Hz line voltage). Disregard the slow drift.

d. Turn the DELAY TIME POSITION dial to 9.00 and adjust it so the time marker is displayed near the center of the display area.

e. CHECK—Jitter on the leading edge of the time marker should not exceed 0.2 divisions (0.5 division if the instrument is being operated on a 50 Hz line voltage). Disregard the slow drift.

79. Check Mixed Sweep Accuracy

a. Set the A TIME/DIV switch to 1 ms, the B TIME/DIV switch to 0.5 ms, the HORIZ DISPLAY switch to A, the B SOURCE switch to STARTS AFTER DELAY, and the DELAY TIME POSITION dial fully clockwise.

b. Select 1 ms time marks from the Time Mark Generator.

c. CHECK—Timing between the second and tenth time markers. Note any timing error for use in step 79-e.

d. Set the HORIZ DISPLAY switch to MIX.

e. CHECK—The timing between second and tenth time markers is within 0.16 division, \pm the A sweep error noted in step 79-c.

f. Disconnect the test setup.

80. Adjust X Gain

a. Set the A TIME/DIV switch to X-Y, the VERT MODE switch to CH 2, both VOLTS/DIV switches to 5 mV, and the CH 1 INPUT COUPLING switch to DC.

b. Apply a 20 mV square-wave from the Standard Amplitude Calibrator to the CH 1 or X input through a 42-inch 50 Ω BNC cable.

c. CHECK—CRT display for 4 divisions of deflection, $\pm 4\%$, between the two displayed dots.

d. ADJUST—X-Gain adjustment R1215 (see Fig. 5-33) for exactly four divisions of deflection between the two dots displayed on the CRT.

e. Disconnect the test setup.

81. Check X-Y Phasing and Bandwidth

a. Set both VOLTS/DIV switches to 5 mV, and both INPUT COUPLING switches to AC.

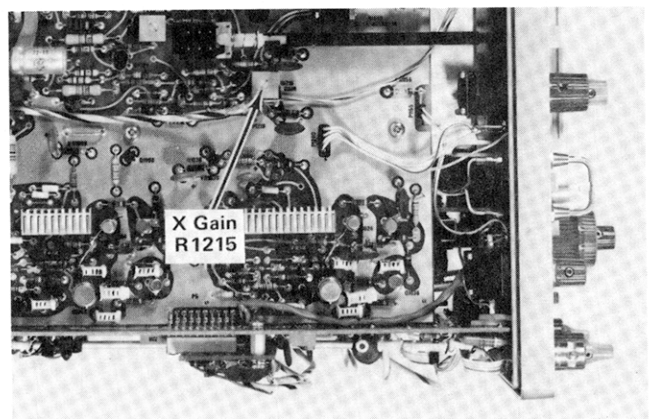

Fig. 5-33. Location of X-Gain adjustment.

b. Connect the output of the Medium-Frequency Constant-Amplitude Signal Generator (Type 191) to the CH 1 and CH 2 inputs through a 42-inch $50\ \Omega$ BNC cable, $50\ \Omega$ BNC termination, and a dual input coupler.

c. Adjust the Medium-Frequency signal generator for an eight division horizontal display of 50 kilohertz.

d. Center the display vertically and horizontally with the CH 1 and CH 2 POSITION controls.

e. CHECK—CRT display for an opening at the center horizontal line of 0.4 division or less (see Fig. 5-34).

f. Remove the dual input coupler from the test setup.

g. Reconnect the test signal to the CH 1 input.

h. Adjust the signal generator for a 10-division horizontal display of 50 kilohertz.

i. Adjust the signal generator frequency until the display is reduced to seven divisions.

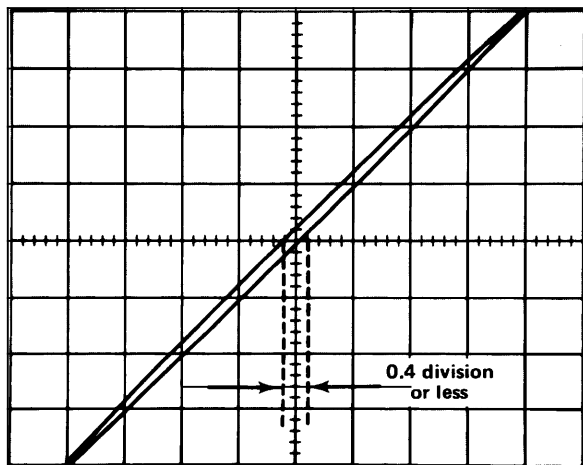

Fig. 5-34. Typical CRT display when checking X-Y phasing.

j. CHECK—Output frequency of the signal generator is at least 4 megahertz.

k. Disconnect the test setup.

82. Check B Ends A Operation

a. Set the HORIZ DISPLAY switch to A INTEN, the A TIME/DIV switch to 1 ms, the B TIME/DIV switch to 0.1 ms, and the A TRIG HOLDOFF control to B ENDS A.

b. Adjust the INTENSITY control so that the A sweep is visible.

c. Rotate the DELAY TIME POSITION dial through its range.

d. CHECK—A sweep ends after the intensified portion at all settings of the DELAY TIME POSITION dial.

83. Check A TRIGGER HOLDOFF

a. Set the HORIZ DISPLAY to A, the A TIME/DIV switch to $50\ \mu\text{s}$, the A TRIG HOLDOFF control fully counterclockwise, and the A TRIG LEVEL control fully clockwise.

b. Connect the A GATE output signal to the Test Oscilloscope via a 42-inch $50\ \Omega$ BNC cable.

c. Set the Test Oscilloscope TIME/DIV switch so that the bottom portion of the waveform (holdoff time of the A GATE) is slightly less than one division in length.

d. Rotate the A TRIG HOLDOFF control clockwise.

e. CHECK—For at least ten times increase in the holdoff time of the A GATE.

f. Set the A TRIG HOLDOFF control fully counterclockwise.

CALIBRATOR, GATES, & EXT Z-AXIS CALIBRATION

Equipment Required

- | | |
|--|--|
| <ol style="list-style-type: none"> 1. Precision DC Voltmeter 2. Test Oscilloscope 3. Standard Amplitude Calibrator 4. 42-Inch 50 Ω BNC Cable | <ol style="list-style-type: none"> 5. BNC-T Connector 6. 15-inch 50 Ω BNC Cable (two) 7. Three-Inch Screwdriver |
|--|--|

Control Settings

Preset instrument controls to the settings given under Preliminary Control Settings.

84. Adjust CALIBRATOR Output

- a. Connect the Precision DC Voltmeter between the CALIBRATION loop and ground.
- b. Install short circuit between the emitter of Q1594 and the collector of Q1590.
- c. CHECK—For a meter reading of +0.3 volt \pm 0.003 volt.
- d. ADJUST—Calibrator Amplitude adjustment, R1597, (see Fig. 5-35) for 0.3 volt, within 1% from 0°C to +40°C; for 0.3 volt, within 1.5% from -15°C to +55°C.
- e. Remove the Precision DC Voltmeter connections.
- f. Remove the short circuit installed in step b.

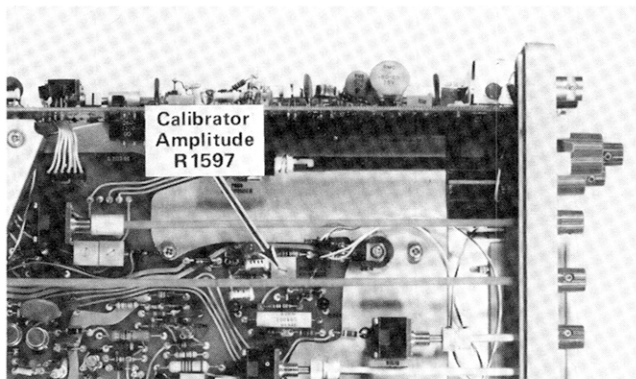

Fig. 5-35. Location of CALIBRATOR Amplitude adjustment.

85. Check A and B + GATES

- a. Set the DELAY TIME POSITION dial fully counterclockwise, the HORIZ DISPLAY switch to B DLY'D, the B SOURCE switch to STARTS AFTER DELAY, B TIME/DIV switch to 50 μs, and the TRIG MODE to AUTO.
- b. Connect the B + GATE signal to the Test Oscilloscope via a 42-inch 50 Ω BNC cable.
- c. CHECK—Test Oscilloscope for a positive-going pulse of +5.5 V in amplitude (within 0.5 V).
- d. Remove the B + GATE signal and connect the A + GATE signal to the Test Oscilloscope via a 42-inch 50 Ω BNC cable.
- e. CHECK—Test Oscilloscope for a positive-going pulse of +5.5 V in amplitude (within 0.5 V).
- f. Disconnect the test setup.

86. Check EXT Z-AXIS Operation

- a. Set HORIZ DISPLAY switch to A, A TIME/DIV switch to 0.2 ms, and the A SOURCE switch to EXT.
- b. Set the INTENSITY control for a normal level.
- c. Connect the Standard Amplitude Calibrator to the A External Trigger Input and the EXT Z-AXIS input via a 42-inch 50 Ω BNC cable, a BNC-T connector, and two 18-inch 50 Ω BNC cables.
- d. Adjust the Standard Amplitude Calibrator for a 5 V output.
- e. CHECK—CRT display for noticeable intensity modulation.
- f. Disconnect the test setup.

ELECTRICAL PARTS LIST

Replacement parts should be ordered from the Tektronix Field Office or Representative in your area. Changes to Tektronix products give you the benefit of improved circuits and components. Please include the instrument type number and serial number with each order for parts or service.

ABBREVIATIONS AND REFERENCE DESIGNATORS

| | | | | | |
|--------|-----------------------------------|-----|--|-----|---|
| A | Assembly, separable or repairable | FL | Filter | PTM | paper or plastic, tubular molded |
| AT | Attenuator, fixed or variable | H | Heat dissipating device (heat sink, etc.) | R | Resistor, fixed or variable |
| B | Motor | HR | Heater | RT | Thermistor |
| BT | Battery | J | Connector, stationary portion | S | Switch |
| C | Capacitor, fixed or variable | K | Relay | T | Transformer |
| Cer | Ceramic | L | Inductor, fixed or variable | TP | Test point |
| CR | Diode, signal or rectifier | LR | Inductor/resistor combination | U | Assembly, inseparable or non-repairable |
| CRT | cathode-ray tube | M | Meter | V | Electron tube |
| DL | Delay line | Q | Transistor or silicon-controlled rectifier | Var | Variable |
| DS | Indicating device (lamp) | P | Connector, movable portion | VR | Voltage regulator (zener diode, etc.) |
| Elect. | Electrolytic | PMC | Paper, metal cased | WW | wire-wound |
| EMC | electrolytic, metal cased | PT | paper, tubular | Y | Crystal |
| EMT | electrolytic, metal tubular | | | | |
| F | Fuse | | | | |

| Ckt. No. | Tektronix Part No. | Serial/Model No. Eff | Disc | Description |
|-------------------|--------------------|----------------------|---------|---|
| ASSEMBLIES | | | | |
| A1 | 670-2434-00 | | | CH 1 ATTEN Circuit Board Assembly |
| A2 | 670-2434-00 | | | CH 2 ATTEN Circuit Board Assembly |
| A3 | 670-2237-00 | | | VERT PREAMP. Circuit Board Assembly |
| A4 | 670-2236-00 | | | VERT MODE Circuit Board Assembly |
| A5 | 670-2238-00 | B010100 | B039999 | VERT OUTPUT Circuit Board Assembly |
| A5 | 670-0323-00 | | B040000 | VERT OUTPUT Circuit Board Assembly |
| A6 | 670-2245-00 | | | FAN MOTOR Circuit Board Assembly |
| A7 | 670-2235-00 | B010100 | B010155 | TIMING Circuit Board Assembly |
| A7 | 670-2235-01 | | B010156 | TIMING Circuit Board Assembly |
| A8 | 670-2234-00 | | | TRIG GEN & SWP LOGIC Circuit Board Assembly |
| A9 | 670-2233-00 | B010100 | B010155 | INTERFACE Circuit Board Assembly |
| A9 | 670-2233-01 | | B010156 | INTERFACE Circuit Board Assembly |
| A10 | 670-2279-00 | | | GRATICULE ILLUM Circuit Board Assembly |
| A11 | 670-2520-00 | | | TRIG VIEW Circuit Board Assembly |
| MOTOR | | | | |
| B1690 | 147-0035-00 | | | Motor, DC brushless, 10-15 VDC, 145 mA |
| CAPACITORS | | | | |
| C1 | 281-0064-00 | | | 0.25-1.5 pF, Var, Tub., 600 V |
| C2 | 281-0627-00 | | | 1 pF, (nominal value), selected |
| C3 | 285-0816-01 | | | 0.019 uF, Plastic, 600 V, 10% |
| C6 | 283-0000-00 | | | 0.001 uF, Cer, 500 V, +100%-0% |
| C7 | 283-0000-00 | | | 0.001 uF, Cer, 500 V, +100%-0% |
| C10} (2) | 307-1014-00 | B010100 | B019999 | Attenuator strip, 100X |
| C11} | | | | |
| C10} (2) | 307-1014-01 | B020000 | B029999 | Attenuator strip, 100X |
| C11} | | | | |

| Ckt. No. | Tektronix Part No. | Serial/Model No. Eff | Disc | Description |
|-------------------|--------------------|----------------------|---------|----------------------------------|
| CAPACITORS (cont) | | | | |
| C10 | (2) 307-1014-02 | B030000 | | Attenuator strip, 100X |
| C11 | | | | |
| C12 | (2) 307-1013-00 | B010100 | B019999 | Attenuator strip, 10X |
| C13 | | | | |
| C12 | (2) 307-1013-01 | B020000 | | Attenuator strip, 10X |
| C13 | | | | |
| C16 | 283-0001-00 | | | 0.005 uF, Cer, 500 V |
| C18 | 281-0593-00 | | | 3.9 pF, Cer, 10% |
| C21 | 283-0081-00 | B010100 | B010349 | 0.1 uF, Cer, 25 V, +80%-20% |
| C21 | 283-0004-00 | B010350 | | 0.02 uF, Cer, 150 V |
| C22 | 283-0087-00 | | | 300 pF, Cer, 100 V, 10% |
| C23 | 290-0517-00 | | | 6.8 uF, Elect., 35 V, 20% |
| C25 | 283-0004-00 | | | 0.02 uF, Cer, 150 V |
| C27 | 281-0184-00 | XB010250 | | 2-18 pF, Var, Plastic |
| C33 | 281-0178-00 | | | 1-4 pF, Var, Plastic, 500 V |
| C34 | 283-0139-00 | | | 150 pF, Cer, 50 V, 20% |
| C36 | 283-0004-00 | XB030000 | | 0.02 uF, Cer, 150 V |
| C37 | 281-0536-00 | | | 1000 pF, Cer, 500 V, 10% |
| C38 | 281-0536-00 | | | 1000 pF, Cer, 500 V, 10% |
| C39 | 283-0004-00 | | | 0.02 uF, Cer, 150 V |
| C42 | 283-0004-00 | | | 0.02 uF, Cer, 150 V |
| C46 | 281-0626-00 | | | 3.3 pF, Cer, 500 V, 5% |
| C47 | 281-0184-00 | | | 2-18 pF, Var, Plastic, 500 V |
| C48 | 280-0184-00 | | | 2-18 pF, Var, Plastic, 500 V |
| C49 | 283-0136-00 | B010100 | B010249 | 10 pF, Cer, 50 V, 5% |
| C49 | 281-0621-00 | B010250 | | 12 pF, Cer, 500 V, 1% |
| C51 | 281-0064-00 | | | 0.25-1.5 pF, Var, Tub., 600 V |
| C52 | 281-0627-00 | | | 1 pF, (nominal value), selected |
| C53 | 285-0816-01 | | | 0.019 uF, Plastic, 600 V, 10% |
| C56 | 283-0000-00 | | | 0.001 uF, Cer, 500 V, +100%-0% |
| C57 | 283-0000-00 | | | 0.001 uF, Cer, 500 V, +100%-0% |
| C66 | 283-0001-00 | | | 0.005 uF, Cer, 500 V |
| C68 | 281-0593-00 | | | 3.9 pF, Cer, 10% |
| C71 | 283-0081-00 | B010100 | B010349 | 0.1 uF, Cer, 25 V, +80%-20% |
| C71 | 283-0004-00 | B010350 | | 0.02 uF, Cer, 150 V |
| C72 | 283-0087-00 | | | 300 pF, Cer, 1000 V, 10% |
| C73 | 290-0517-00 | | | 6.8 uF, Elect., 35 V, 20% |
| C75 | 283-0004-00 | | | 0.02 uF, Cer, 150 V |
| C77 | 281-0504-00 | B010100 | B010249 | 10 pF, (nominal value), selected |
| C77 | 281-0184-00 | B010250 | | 2-8 pF, Var, Plastic, 500 V |
| C82 | 290-0517-00 | XB010152 | | 6.8 uF, Elect., 35 V, 20% |
| C83 | 281-0184-00 | | | 2-18 pF, Var, Plastic, 500 V |
| C84 | 283-0139-00 | | | 150 pF, Cer, 50 V, 20% |
| C87 | 281-0536-00 | | | 1000 pF, Cer, 500 V, 10% |
| C88 | 281-0536-00 | | | 1000 pF, Cer, 500 V, 10% |

| Ckt. No. | Tektronix Part No. | Serial/Model No. Eff | Disc | Description |
|-------------------|--------------------|----------------------|---------|------------------------------------|
| CAPACITORS (cont) | | | | |
| C92 | 283-0004-00 | | | 0.02 uF, Cer, 150 V |
| C96 | 281-0626-00 | | | 3.3 pF, Cer, 500 V, 5% |
| C97 | 281-0184-00 | | | 2-18 pF, Var, Plastic, 500 V |
| C98 | 281-0184-00 | | | 2-18 pF, Var, Plastic, 500 V |
| C99 | 283-0136-00 | B010100 | B010249 | 10 pF, Cer, 50 V, 5% |
| C99 | 281-0626-00 | B010250 | | 12 pF, Cer, 500 V, 1% |
| C101 | 281-0628-00 | | | 15 pF, Cer, 600 V, 5% |
| C102 | 290-0517-00 | | | 6.8 uF, Elect., 35 V, 20% |
| C103 | 281-0604-00 | XB010250 | | 2.2 pF, Cer, 500 V, ±0.25 pF |
| C105 | 281-0184-00 | | | 2-18 pF, Var, Plastic, 500 V |
| C107 | 281-0536-00 | | | 1000 pF, Cer, 500 V, 10% |
| C109 | 281-0536-00 | | | 1000 pF, Cer, 500 V, 10% |
| C122 | 281-0572-00 | XB010250 | B010349 | 6-8 pF, Cer, 500 V, ±0.5 pF |
| C122 | 281-0184-00 | B010350 | | 2-18 pF, Var, Plastic, 500 V |
| C125 | 290-0517-00 | | | 6.8 uF, Elect., 35 V, 20% |
| C135 | 281-0525-00 | | | 470 pF, Cer, 500 V, 20% |
| C137 | 281-0525-00 | | | 470 pF, Cer, 500 V, 20% |
| C142 | 283-0003-00 | | | 0.01 uF, Cer, 150 V, +80%-20% |
| C144 | 281-0625-00 | | | 35 pF, Cer, 500 V, 5% |
| C149 | 281-0184-00 | | | 2-18 pF, Var, Plastic, 500 V |
| C151 | 281-0525-00 | | | 470 pF, Cer, 500 V, 20% |
| C161 | 290-0517-00 | | | 6.8 uF, Elect., 35 V, 20% |
| C162 | 281-0512-00 | | | 27 pF, Cer, 500 V, 10% |
| C164 | 290-0517-00 | | | 6.8 uF, Elect., 35 V, 20% |
| C201 | 281-0628-00 | | | 15 pF, Cer, 500 V, 5% |
| C202 | 283-0004-00 | | | 0.02 uF, Cer, 150 V |
| C203 | 281-0604-00 | XB010250 | | 2.2 pF, Cer, 50 V, ±0.25 pF |
| C205 | 281-0184-00 | | | 2-18 pF, Var, Plastic, 500 V |
| C207 | 281-0536-00 | | | 1000 pF, Cer, 500 V, 10% |
| C209 | 281-0536-00 | | | 1000 pF, Cer, 500 V, 10% |
| C225 ¹ | 283-0004-00 | | | 0.02 uF, (nominal value), selected |
| C229 | 283-0004-00 | XB010211 | B010349 | 0.02 uF, Cer, 150 V |
| C229 | 290-0517-00 | B010350 | | 6.8 uF, Elect., 35 V, 20% |
| C235 | 281-0525-00 | | | 470 pF, Cer, 500 V, 20% |
| C237 | 281-0525-00 | | | 470 pF, Cer, 500 V, 20% |
| C242 | 283-0003-00 | | | 0.01 uF, Cer, 150 V, +80%-20% |
| C245 | 281-0628-00 | | | 15 pF, Cer, 600 V, 5% |
| C249 | 281-0184-00 | | | 2-18 pF, Var, Plastic, 500 V |
| C251 | 281-0525-00 | | | 470 pF, Cer, 500 V, 20% |
| C253 | 283-0000-00 | | | 0.001 uF, Cer, 500 V, +100%-0% |
| C261 | 290-0517-00 | | | 6.8 uF, Elect., 35 V, 20% |
| C262 | 281-0519-00 | | | 47 pF, Cer, 500 V, 10% |
| C302 | 290-0517-00 | | | 6.8 uF, Elect., 35 V, 20% |
| C321 | 283-0004-00 | | | 0.02 uF, Cer, 150 V |
| C334 | 283-0004-00 | | | 0.02 uF, Cer, 150 V |

¹Added if necessary.

| Ckt. No. | Tektronix Part No. | Serial/Model No. Eff | Disc | Description |
|-------------------|--------------------|----------------------|----------|--------------------------------|
| CAPACITORS (cont) | | | | |
| C338 | 281-0579-00 | | | 21 pF, Cer, 500 V, 5% |
| C339 | 283-0644-00 | | | 150 pF, Mica, 500 V, 1% |
| C345 | 283-0004-00 | XB010250 | | 0.02 uF, Cer, 150 V |
| C346 | 290-0517-00 | | | 6.8 uF, Elect., 35 V, 20% |
| C347 | 281-0508-00 | | | 12 pF, Cer, 500 V, ±0.6 pF |
| C349 | 281-0578-00 | | | 18 pF, Cer, 500 V, 5% |
| C351 | 281-0549-00 | | | 68 pF, Cer, 500 V, 10% |
| C352 | 290-0517-00 | | | 6.8 uF, Elect., 35 V, 20% |
| C354 | 290-0517-00 | | | 6.8 uF, Elect., 35 V, 20% |
| C356 | 281-0549-00 | | | 68 pF, Cer, 500 V, 10% |
| C358 | 290-0517-00 | | | 6.8 uF, Elect., 35 V, 20% |
| C361 | 290-0517-00 | | | 6.8 uF, Elect., 35 V, 20% |
| C362 | 290-0517-00 | | | 6.8 uF, Elect., 35 V, 20% |
| C363 | 290-0517-00 | | | 6.8 uF, Elect., 35 V, 20% |
| C364 | 281-0504-00 | XB010350 | | 10 pF, Cer, 500 V, 10% |
| C368 | 283-0058-00 | | | 0.027 uF, Cer, 100 V, 10% |
| C374 | 281-0504-00 | XB010350 | | 10 pF, Cer, 500 V, 10% |
| C375 | 283-0004-00 | XB010250 | | 0.02 uF, Cer, 150 V |
| C381 | 283-0000-00 | | | 0.001 uF, Cer, 500 V, +100%-0% |
| C391 | 283-0000-00 | | | 0.001 uF, Cer, 500 V, +100%-0% |
| C402 | 283-0032-00 | XB040000 | | 470 pF, Cer, 500 V, 5% |
| C403 | 281-0089-00 | B010100 | B039999X | 2-8 pF, Var, Cer |
| C407 | 283-0081-00 | B010100 | B039999X | 0.1 uF, Cer, 25 V, +80%-20% |
| C412 | 283-0032-00 | XB040000 | | 470 pF, Cer, 500 V, 5% |
| C417 | 283-0081-00 | B010100 | B039999X | 0.1 uF, Cer, 25 V, +80%-20% |
| C422 | 281-0139-00 | XB040000 | | 2.5-9 pF, Var, Cer, 100 V |
| C423 | 283-0180-00 | B010100 | B039999X | 5600 pF, Cer, 200 V, 20% |
| C424 | 283-0167-00 | B010100 | B010894 | 0.1 uF, Cer, 100 V, 10% |
| C424 | 283-0198-00 | B010895 | B039999X | 0.22 uF, Cer, 50 V, 20% |
| C425 | 281-0638-00 | XB040000 | | 240 pF, Cer, 500 V, 5% |
| C426 | 281-0580-00 | XB040000 | | 470 pF, Cer, 500 V, 10% |
| C427 | 281-0524-00 | XB040000 | | 150 pF, Cer, 500 V, 20% |
| C430 | 283-0000-00 | XB040000 | | 0.001 uF, Cer, 500 V, +100%-0% |
| C432 | 283-0065-00 | XB040000 | | 0.001 uF, Cer, 100 V, 5% |
| C433 | 283-0119-00 | B010100 | B039999X | 2200 pF, Cer, 200 V, 5% |
| C434 | 283-0187-00 | B010100 | B029999 | 0.047 uF, Cer, 400 V, 10% |
| C434 | 283-0341-00 | B030000 | B039999X | 0.047 uF, Cer, 100 V, 10% |
| C437 | 281-0629-00 | XB040000 | | 33 pF, Cer, 600 V, 5% |
| C438 | 281-0123-00 | XB040000 | | 5-25 pF, Var, Cer, 100 V |
| C439 | 281-0617-00 | XB040000 | | 15 pF, Cer, 200 V, 10% |
| C441 | 283-0636-00 | B010100 | B039999X | 36 pF, Mica, 100 V, ±0.5 pF |
| C442 | 281-0089-00 | B010100 | B039999 | 2-8 pF, Var, Cer |
| C442 | 283-0065-00 | B040000 | | 0.001 uF, Cer, 100 V, 5% |
| C443 | 281-0096-00 | B010100 | B039999X | 5.5-18 pF, Var, Air |
| C444 | 281-0602-00 | B010100 | B039999 | 68 pF, Cer, 500 V, 5% |

| Ckt. No. | Tektronix Part No. | Serial/Model No. Eff | Disc | Description |
|-------------------|--------------------|----------------------|----------|--------------------------------|
| CAPACITORS (cont) | | | | |
| C444 | 281-0651-00 | B040000 | | 47 pF, Cer, 200 V, 5% |
| C445 | 283-0660-00 | B010100 | B039999X | 510 pF, Mica, 500 V, 2% |
| C451 | 283-0144-00 | B010100 | B039999X | 33 pF, Cer, 500 V, 1% |
| C453 | 283-0000-00 | B010100 | B039999X | 0.001 uF, Cer, 500 V, +100%-0% |
| C457 | 283-0010-00 | B010100 | B039999X | 0.05 uF, Cer, 50 V |
| C458 | 283-0081-00 | B010100 | B039999X | 0.1 uF, Cer, 25 V, +80%-20% |
| C459 | 283-0023-00 | B010100 | B039999X | 0.1 uF, Cer, 10 V, +80%-20% |
| C464 ¹ | 283-0178-00 | B010100 | B039999 | 0.1 uF, Cer, 100 V, +80%-20% |
| C464 ¹ | | B040000 | | |
| C469 | 281-0500-00 | XB040000 | | 2.2 pF, Cer, 500 V, ±0.5 pF |
| C471 ¹ | 283-0178-00 | B010100 | B039999X | 0.1 uF, Cer, 100 V, +80%-20% |
| C474 ¹ | | XB040000 | | |
| C481 | 283-0032-00 | XB040000 | | 470 pF, Cer, 500 V, 5% |
| C482 | 283-0000-00 | XB040000 | | 0.001 uF, Cer, 500 V, +100%-0% |
| C485 | 283-0003-00 | XB040000 | | 0.01 uF, Cer, 150 V, +80%-20% |
| C491 | 283-0032-00 | XB040000 | | 470 pF, Cer, 500 V, 5% |
| C492 | 283-0000-00 | XB040000 | | 0.001 uF, Cer, 500 V, +100%-0% |
| C498 | 290-0523-00 | XB040000 | | 2.2 uF, Elect., 20 V, 20% |
| C499 | 290-0523-00 | XB040000 | | 2.2 uF, Elect., 20 V, 20% |
| C502 | 281-0579-00 | | | 21 pF, Cer, 500 V, 5% |
| C503 | 281-0651-00 | | | 47 pF, Cer, 200 V, 5% |
| C511 | 281-0523-00 | | | 100 pF, Cer, 350 V, 20% |
| C512 | 283-0004-00 | | | 0.02 uF, Cer, 150 V |
| C515 | 281-0511-00 | | | 22 pF, Cer, 500 V, 10% |
| C522 | 283-0003-00 | | | 0.01 uF, Cer, 150 V, +80%-20% |
| C525 | 283-0003-00 | | | 0.01 uF, Cer, 150 V, +80%-20% |
| C528 | 281-0511-00 | | | 22 pF, Cer, 500 V, 10% |
| C531 | 283-0003-00 | | | 0.01 uF, Cer, 150 V, +80%-20% |
| C549 | 283-0003-00 | | | 0.01 uF, Cer, 150 V, +80%-20% |
| C601 | 283-0003-00 | B010100 | B010399 | 0.01 uF, Cer, 150 V, +80%-20% |
| C601 | 283-0167-00 | B010400 | | 0.1 uF, Cer, 100 V, 10% |
| C603 | 281-0670-00 | | | 1.8 pF, Cer, 500 V, ±0.1 pF |
| C604 | 281-0523-00 | | | 100 pF, Cer, 350 V, 20% |
| C606 | 281-0628-00 | | | 15 pF, Cer, 600 V, 5% |
| C607 | 281-0515-00 | | | 27 pF, Cer, 500 V, ±1.35 pF |
| C611 | 281-0523-00 | | | 100 pF, Cer, 250 V, 20% |
| C612 | 283-0004-00 | | | 0.02 uF, Cer, 150 V |
| C615 | 281-0511-00 | | | 22 pF, Cer, 500 V, 10% |
| C622 | 283-0003-00 | | | 0.01 uF, Cer, 150 V, +80%-20% |
| C625 | 283-0003-00 | | | 0.01 uF, Cer, 150 V, +80%-20% |
| C628 | 281-0511-00 | | | 22 pF, Cer, 500 V, 10% |
| C631 | 283-0003-00 | | | 0.01 uF, Cer, 150 V, +80%-20% |
| C649 | 283-0003-00 | | | 0.01 uF, Cer, 150 V, +80%-20% |
| C674 | 281-0518-00 | B010100 | B010804X | 47 pF, Cer, 500 V, 20% |
| C674 | 281-0501-00 | XB011200 | | 4.7 pF, Cer, 500 V, ±1 pF |

¹Part of Circuit Board.

| Ckt. No. | Tektronix Part No. | Serial/Model No. Eff | Disc | Description |
|-------------------|--------------------|----------------------|----------|----------------------------------|
| CAPACITORS (cont) | | | | |
| C676 | 281-0646-00 | B010100 | B010804 | 88 pF, Cer, 500 V, 5% |
| C676 | 281-0540-00 | B010805 | | 51 pF, (nominal value), selected |
| C684 | 281-0626-00 | B010100 | B010804X | 3.3 pF, Cer, 500 V, 5% |
| C690 | 283-0081-00 | B010100 | B010352 | 0.1 uF, Cer, 25 V, +80%-20% |
| C690 | 283-0024-00 | B010353 | | 0.1 uF, Cer, 30 V, +80%-20% |
| C697 | 283-0081-00 | B010100 | B010352 | 0.1 uF, Cer, 25 V, +80%-20% |
| C697 | 283-0023-00 | B010353 | | 0.1 uF, Cer, 10 V, +80%-20% |
| C699 | 283-0081-00 | B010100 | B010352 | 0.1 uF, Cer, 25 V, +80%-20% |
| C699 | 283-0023-00 | B010353 | | 0.1 uF, Cer, 10 V, +80%-20% |
| C805 | 290-0527-00 | | | 15 uF, Elect., 20 V, 20% |
| C808 | 281-0577-00 | | | 14 pF, Cer, 500 V, 5% |
| C824 | 281-0511-00 | | | 22 pF, Cer, 500 V, 10% |
| C826 | 281-0523-00 | | | 100 pF, Cer, 350 V, 20% |
| C829 | 290-0529-00 | | | 47 uF, Elect., 20 V, 20% |
| C834 | 290-0527-00 | | | 15 uF, Elect., 20 V, 20% |
| C835 | 290-0527-00 | | | 15 uF, Elect., 20 V, 20% |
| C836 | 290-0527-00 | | | 15 uF, Elect., 20 V, 20% |
| C837 | 281-0524-00 | | | 150 pF, Cer, 500 V, 20% |
| C839 | 290-0536-00 | | | 10 uF, Elect., 25 V, 20% |
| C853 | 283-0024-00 | | | 0.1 uF, Cer, 30 V, +80%-20% |
| C855 | 290-0527-00 | | | 15 uF, Elect., 20 V, 20% |
| C858 | 281-0577-00 | | | 14 pF, Cer, 500 V, 5% |
| C874 | 290-0527-00 | | | 15 uF, Elect., 20 V, 20% |
| C877 | 281-0508-00 | | | 12 pF, Cer, 500 V, 20% |
| C879 | 290-0522-00 | | | 1 uF, Elect., 50 V, 20% |
| C891 | 290-0527-00 | | | 15 uF, Elect., 20 V, 20% |
| C893 | 290-0527-00 | | | 15 uF, Elect., 20 V, 20% |
| C896 | 290-0527-00 | | | 15 uF, Elect., 20 V, 20% |
| C897 | 290-0527-00 | | | 15 uF, Elect., 20 V, 20% |
| C1000 | 283-0004-00 | | | 0.02 uF, Cer, 150 V |
| C1002 | 283-0178-00 | | | 0.1 uF, Cer, 100 V, +80%-20% |
| C1003 | 281-0637-00 | | | 91 pF, Cer, 500 V, 5% |
| C1005 | 281-0629-00 | | | 33 pF, Cer, 600 V, 5% |
| C1017 | 281-0511-00 | | | 22 pF, Cer, 500 V, 10% |
| C1021 | 283-0004-00 | | | 0.02 uF, Cer, 150 V |
| C1024 | 290-0527-00 | | | 15 uF, Elect., 20 V, 20% |
| C1026 | 281-0523-00 | | | 100 pF, Cer, 350 V, 20% |
| C1031 | 283-0004-00 | | | 0.02 uF, Cer, 150 V |
| C1036 | 281-0578-00 | | | 18 pF, Cer, 500 V, 5% |
| C1038 | 290-0527-00 | | | 15 uF, Elect., 20 V, 20% |
| C1039 | 283-0023-00 | | | 0.1 uF, Cer, 10 V, +80%-20% |
| C1062 | 283-0178-00 | | | 0.1 uF, Cer, 100 V, +80%-20% |
| C1063 | 281-0637-00 | | | 91 pF, Cer, 500 V, 5% |
| C1065 | 281-0629-00 | | | 33 pF, Cer, 600 V, 5% |
| C1077 | 281-0511-00 | | | 22 pF, Cer, 500 V, 10% |

| Ckt. No. | Tektronix Part No. | Serial/Model No. Eff | Disc | Description |
|-------------------|--------------------|----------------------|------|-------------------------------|
| CAPACITORS (cont) | | | | |
| | C1081 | 283-0004-00 | | 0.02 uF, Cer, 150 V |
| | C1084 | 290-0527-00 | | 15 uF, Elect., 20 V, 20% |
| | C1086 | 281-0523-00 | | 100 pF, Cer, 350 V, 20% |
| | C1091 | 283-0004-00 | | 0.02 uF, Cer, 150 V |
| | C1096 | 281-0578-00 | | 18 pF, Cer, 500 V, 5% |
| | C1099 | 283-0023-00 | | 0.1 uF, Cer, 10 V, +80%-20% |
| | C1113 | 290-0519-00 | | 100 uF, Elect., 20 V, 20% |
| | C1117 | 283-0080-00 | | 0.022 uF, Cer, 25 V, +80%-20% |
| | C1131 | 295-0160-00 | | 10 uF, |
| | C1133 | | | 0.1 uF, Timing capacitor |
| | C1135 | | | 0.001 uF, |
| | C1137 | | | 2-8 pF, Var, Cer |
| | C1138 | | | 43 pF, Cer, 100 V, 2% |
| | C1151 | 283-0268-00 | | 0.015 uF, Cer, 50 V, 10% |
| | C1152 | 290-0245-00 | | 1.5 uF, Elect., 10 V, 10% |
| | C1153 | 283-0645-00 | | 790 pF, Mica, 100 V, 1% |
| | C1161 | 295-0157-00 | | 1 uF, |
| | C1163 | | | 0.1 uF, Timing capacitor |
| | C1165 | | | 0.001 uF, |
| | C1167 | | | 2-8 pF, Var, Cer |
| | C1168 | | | 43 pF, Cer, 100 V, 2% |
| | C1201 | 283-0023-00 | | 0.1 uF, Cer, 10 V, +80%-20% |
| | C1208 | 283-0004-00 | | 0.02 uF, Cer, 150 V |
| | C1209 | 283-0004-00 | | 0.02 uF, Cer, 150 V |
| | C1220 | 290-0650-00 | | 1000 uF, Elect., 10 V, 20% |
| | C1235 | 283-0178-00 | | 0.1 uF, Cer, 100 V, +80%-20% |
| | C1249 | 283-0004-00 | | 0.02 uF, Cer, 150 V |
| | C1256 | 283-0024-00 | | 0.1 uF, Cer, 30 V, +80%-20% |
| | C1261 | 281-0064-00 | | 0.25-1.5 pF, Var, Tub., 600 V |
| | C1262 | 283-0092-00 | | 0.03 uF, Cer, 200 V, +80%-20% |
| | C1263 | 283-0003-00 | | 0.01 uF, Cer, 150 V, +80%-20% |
| | C1269 | 283-0003-00 | | 0.01 uF, Cer, 150 V, +80%-20% |
| | C1281 | 281-0064-00 | | 0.25-1.5 pF, Var, Tub., 600 V |
| | C1282 | 283-0092-00 | | 0.03 uF, Cer, 200 V, +80%-20% |
| | C1283 | 283-0003-00 | | 0.01 uF, Cer, 150 V, +80%-20% |
| | C1288 | 283-0003-00 | | 0.01 uF, Cer, 150 V, +80%-20% |
| | C1299 | 283-0004-00 | | 0.02 uF, Cer, 150 V |
| | C1307 | 281-0501-00 | | 4.7 pF, Cer, 500 V, ±1 pF |
| | C1327 | 281-0501-00 | | 4.7 pF, Cer, 500 V, ±1 pF |
| | C1339 | 283-0023-00 | | 0.1 uF, Cer, 10 V, +80%-20% |
| | C1348 | 283-0023-00 | | 0.1 uF, Cer, 10 V, +80%-20% |
| | C1349 | 283-0023-00 | | 0.1 uF, Cer, 10 V, +80%-20% |
| | C1403 | 283-0198-00 | | 0.22 uF, Cer, 50 V, 20% |
| | C1404 | 290-0159-00 | | 2 uF, Elect., 150 V |
| | C1412 | 290-0536-00 | | 10 uF, Elect., 25 V, 20% |

¹ Individual timing capacitors in this assembly must be ordered by the 9 digit part number, letter suffix and tolerance printed on the timing capacitor to be replaced.
Example:

_____ | 285-XXXX-XX F- | _____

The letter suffix and the tolerance should be the same for all of the timing capacitors in the assembly.

| Ckt. No. | Tektronix Part No. | Serial/Model No. Eff | Disc | Description |
|-------------------|--------------------|----------------------|---------|----------------------------------|
| CAPACITORS (cont) | | | | |
| C1416 | 283-0203-00 | | | 0.47 uF, Cer, 50 V, 20% |
| C1419 | 290-0560-00 | | | 47 uF, Elect., 25 V, 20% |
| C1420 | 281-0622-00 | | | 47 pF, Cer, 500 V, 1% |
| C1421 | 283-0071-00 | | | 0.0068 uF, Cer, 5000 V, +80%-30% |
| C1422 | 283-0071-00 | | | 0.0068 uF, Cer, 5000 V, +80%-30% |
| C1423 | 283-0071-00 | | | 0.0068 uF, Cer, 5000 V, +80%-30% |
| C1424 | 285-1040-00 | | | 0.0012 uF, Plastic, 4000 V, 10% |
| C1430 | 285-1040-00 | | | 0.0012 uF, Plastic, 4000 V, 10% |
| C1434 | 283-0005-00 | | | 0.01 uF, Cer, 250 V, +100%-0% |
| C1442 | 283-0003-00 | | | 0.01 uF, Cer, 150 V, +80%-20% |
| C1445 | 283-0003-00 | | | 0.01 uF, Cer, 150 V, +80%-20% |
| C1447 | 283-0003-00 | | | 0.01 uF, Cer, 150 V, +80%-20% |
| C1449 | 283-0003-00 | | | 0.01 uF, Cer, 150 V, +80%-20% |
| C1452 | 281-0580-00 | | | 470 pF, Cer, 500 V, 10% |
| C1469 | 281-0661-00 | | | 0.8 pF, Cer, 500 V, ±0.1 pF |
| C1471 | 281-0064-00 | | | 0.25-1.5 pF, Var, Tub., 600 V |
| C1474 | 283-0111-00 | | | 0.1 uF, Cer, 50 V |
| C1475 | 283-0000-00 | | | 0.001 uF, Cer, 500 V, +100%-0% |
| C1476 | 283-0057-00 | | | 0.1 uF, Cer, 200 V, +80%-20% |
| C1481 | 290-0164-00 | | | 1 uF, Elect., 150 V |
| C1484 | 283-0178-00 | | | 0.1 uF, Cer, 100 V, +80%-20% |
| C1487 | 283-0101-00 | | | 4700 pF, Cer, 6000 V, +80%-20% |
| C1488 | 285-1040-00 | | | 0.0012 uF, Plastic, 4000 V, 10% |
| C1510 | 283-0057-00 | B010100 | B010399 | 0.1 uF, Cer, 200 V, +80%-20% |
| C1510 | 283-0167-00 | B010400 | | 0.1 uF, Cer, 100 V, 10% |
| C1511 | 281-0536-00 | B010300 | B010399 | 100 pF, Cer, 500 V, 10% |
| C1511 | 281-0580-00 | B010400 | | 470 pF, Cer, 500 V, 10% |
| C1512 | 290-0639-00 | | | 300 uF, Elect., 80 V, +75%-10% |
| C1513 | 290-0638-00 | | | 1200 uF, Elect., 100 V, +75%-10% |
| C1522 | 283-0004-00 | | | 0.02 uF, Cer, 150 V |
| C1525 | 283-0178-00 | XB011052 | | 0.1 uF, Cer, 100 V, +80%-20% |
| C1534 | 290-0305-00 | | | 3 uF, Elect., 150 V, 20% |
| C1537 | 281-0550-00 | | | 120 pF, Cer, 500 V, 10% |
| C1542 | 290-0584-00 | | | 5500 uF, Elect., 30 V, +100%-10% |
| C1549 | 290-0536-00 | | | 10 uF, Elect., 25 V, 20% |
| C1552 | 290-0571-00 | | | 500 uF, Elect., 25 V, +100%-10% |
| C1559 | 290-0535-00 | | | 33 uF, Elect., 10 V, 20% |
| C1562 | 290-0583-00 | | | 3000 uF, Elect., 35 V, +100%-10% |
| C1569 | 290-0535-00 | | | 33 uF, Elect., 10 V, 20% |
| C1587 | 290-0523-00 | | | 2.2 uF, Elect., 20 V, 20% |
| C1592 | 285-0686-00 | | | 0.068 uF, PTM, 100 V, 10% |
| C1593 | 281-0551-00 | | | 390 pF, Cer, 500 V, 10% |
| C1596 | 290-0532-00 | | | 150 uF, Elect., 6 V, 20% |
| C1597 | 281-0513-00 | | | 27 pF, Cer, 500 V, 20% |
| C1698 | 290-0536-00 | | | 10 uF, Elect., 25 V, 20% |

| Ckt. No. | Tektronix Part No. | Serial/Model No. Eff | Disc | Description |
|----------|--------------------|----------------------|----------|---|
| DIODES | | | | |
| CR18 | 152-0323-00 | | | Silicon, SE365 |
| CR31 | 152-0141-02 | | | Silicon, 1N4152 |
| CR32 | 152-0141-02 | | | Silicon, 1N4152 |
| CR34 | 152-0271-00 | | | Voltage variable capacitance, V10E |
| CR39 | 152-0460-00 | | | Silicon, JFET, 1 mA constant current, 1N5297 |
| CR68 | 152-0323-00 | | | Silicon, SE365 |
| CR81 | 152-0141-02 | | | Silicon, 1N4152 |
| CR82 | 152-0141-02 | | | Silicon, 1N4152 |
| CR84 | 152-0271-00 | | | Voltage variable capacitance, V10E |
| CR152 | 152-0141-02 | | | Silicon, 1N4152 |
| CR164 | 152-0141-02 | | | Silicon, 1N4152 |
| CR165 | 152-0141-02 | | | Silicon, 1N4152 |
| CR166 | 152-0141-02 | | | Silicon, 1N4152 |
| CR167 | 152-0141-02 | | | Silicon, 1N4152 |
| CR252 | 152-0141-02 | | | Silicon, 1N4152 |
| CR304 | 152-0153-00 | | | Silicon, FD7003 or CD5574 |
| CR305 | 152-0153-00 | | | Silicon, FD7003 or CD5574 |
| CR307 | 152-0153-00 | | | Silicon, FD7003 or CD5574 |
| CR308 | 152-0153-00 | | | Silicon, FD7003 or CD5574 |
| CR314 | 152-0153-00 | | | Silicon, FD7003 or CD5574 |
| CR315 | 152-0153-00 | | | Silicon, FD7003 or CD5574 |
| CR317 | 152-0153-00 | | | Silicon, FD7003 or CD5574 |
| CR318 | 152-0153-00 | | | Silicon, FD7003 or CD5574 |
| CR342 | 152-0141-02 | | | Silicon, 1N4152 |
| CR362 | 152-0141-02 | | | Silicon, 1N4152 |
| CR368 | 152-0141-02 | | | Silicon, 1N4152 |
| CR372 | 152-0141-02 | | | Silicon, 1N4152 |
| CR378 | 152-0141-02 | | | Silicon, 1N4152 |
| CR421 | 152-0269-00 | B010100 | B039999X | Silicon, selected from 1N3182 |
| CR422 | 152-0269-00 | B010100 | B039999X | Silicon, selected from 1N3182 |
| CR434 | 152-0422-00 | XB040000 | | Silicon, voltage variable capacitance, PE1084 |
| CR451 | 152-0141-02 | XB040000 | | Silicon, 1N4152 |
| CR452 | 152-0141-02 | XB040000 | | Silicon, 1N4152 |
| CR517 | 152-0246-00 | | | Silicon, CD12676 or CD3375 |
| CR550 | 152-0125-00 | | | Tunnel, 4.7 mA, 15 pF |
| CR552 | 152-0125-00 | | | Tunnel, 4.7 mA, 15 pF |
| CR553 | 152-0141-02 | | | Silicon, 1N4152 |
| CR554 | 152-0141-02 | | | Silicon, 1N4152 |
| CR617 | 152-0246-00 | | | Silicon, CD12676 or FD3375 |
| CR650 | 152-0125-00 | | | Tunnel, 4.7 mA, 15 pF |
| CR652 | 152-0125-00 | | | Tunnel, 4.7 mA, 15 pF |
| CR801 | 152-0322-00 | | | Silicon, A1108 |
| CR809 | 152-0141-02 | | | Silicon, 1N4152 |
| CR818 | 152-0141-02 | | | Silicon, 1N4152 |
| CR822 | 152-0141-02 | | | Silicon, 1N4152 |

Electrical Parts List-465

| Ckt. No. | Tektronix Part No. | Serial/Model No. Eff | Disc | Description |
|---------------|--------------------|----------------------|------|---------------------------|
| DIODES (cont) | | | | |
| CR825 | 152-0141-02 | | | Silicon, 1N4152 |
| CR826 | 152-0141-02 | | | Silicon, 1N4152 |
| CR831 | 152-0141-02 | | | Silicon, 1N4152 |
| CR832 | 152-0141-02 | | | Silicon, 1N4152 |
| CR838 | 152-0141-02 | | | Silicon, 1N4152 |
| CR851 | 152-0322-00 | | | Silicon, A1108 |
| CR859 | 152-0141-02 | | | Silicon, 1N4152 |
| CR863 | 152-0141-02 | XB010600 | | Silicon, 1N4152 |
| CR879 | 152-0141-02 | | | Silicon, 1N4152 |
| CR1001 | 152-0141-02 | | | Silicon, 1N4152 |
| CR1004 | 152-0141-02 | | | Silicon, 1N4152 |
| CR1011 | 152-0141-02 | | | Silicon, 1N4152 |
| CR1024 | 152-0141-02 | | | Silicon, 1N4152 |
| CR1035 | 152-0141-02 | | | Silicon, 1N4152 |
| CR1042 | 152-0141-02 | | | Silicon, 1N4152 |
| CR1043 | 152-0141-02 | | | Silicon, 1N4152 |
| CR1061 | 152-0141-02 | | | Silicon, 1N4152 |
| CR1064 | 152-0141-02 | | | Silicon, 1N4152 |
| CR1071 | 152-0141-02 | | | Silicon, 1N4152 |
| CR1095 | 152-0141-02 | | | Silicon, 1N4152 |
| CR1101 | 152-0141-02 | | | Silicon, 1N4152 |
| CR1102 | 152-0141-02 | | | Silicon, 1N4152 |
| CR1155 | 152-0333-00 | | | Silicon, FDH6012 |
| CR1201 | 152-0141-02 | | | Silicon, 1N4152 |
| CR1202 | 152-0141-02 | | | Silicon, 1N4152 |
| CR1216 | 152-0141-02 | | | Silicon, 1N4152 |
| CR1248 | 152-0141-02 | | | Silicon, 1N4152 |
| CR1251 | 152-0153-00 | | | Silicon, FD7003 or CD5574 |
| CR1252 | 152-0153-00 | | | Silicon, FD7003 or CD5574 |
| CR1253 | 152-0322-00 | | | Silicon, A1108 |
| CR1255 | 152-0141-02 | | | Silicon, 1N4152 |
| CR1273 | 152-0322-00 | | | Silicon, A1108 |
| CR1275 | 152-0141-02 | | | Silicon, 1N4152 |
| CR1286 | 152-0141-02 | | | Silicon, 1N4152 |
| CR1304 | 152-0141-02 | | | Silicon, 1N4152 |
| CR1306 | 152-0141-02 | | | Silicon, 1N4152 |
| CR1309 | 152-0141-02 | | | Silicon, 1N4152 |
| CR1315 | 152-0141-02 | | | Silicon, 1N4152 |
| CR1316 | 152-0141-02 | | | Silicon, 1N4152 |
| CR1325 | 152-0141-02 | | | Silicon, 1N4152 |
| CR1326 | 152-0141-02 | | | Silicon, 1N4152 |
| CR1327 | 152-0141-02 | | | Silicon, 1N4152 |
| CR1334 | 152-0141-02 | | | Silicon, 1N4152 |
| CR1335 | 152-0141-02 | | | Silicon, 1N4152 |
| CR1336 | 152-0141-02 | | | Silicon, 1N4152 |

| Ckt. No. | Tektronix Part No. | Serial/Model No. Eff | Disc | Description |
|---------------|--------------------|----------------------|------|---|
| DIODES (cont) | | | | |
| CR1341 | 152-0141-02 | | | Silicon, 1N4152 |
| CR1342 | 152-0141-02 | | | Silicon, 1N4152 |
| CR1344 | 152-0141-02 | | | Silicon, 1N4152 |
| CR1345 | 152-0141-02 | | | Silicon, 1N4152 |
| CR1347 | 152-0141-02 | | | Silicon, 1N4152 |
| CR1404 | 152-0333-00 | | | Silicon, FDH6012 |
| CR1408 | 152-0141-02 | | | Silicon, 1N4152 |
| CR1412 | 152-0141-02 | | | Silicon, 1N4152 |
| CR1413 | 152-0141-02 | | | Silicon, 1N4152 |
| CR1414 | 152-0141-02 | | | Silicon, 1N4152 |
| CR1416 | 152-0333-00 | | | Silicon, FDH6012 |
| CR1421 | 152-0409-00 | | | Silicon, VG-12X |
| CR1461 | 152-0141-02 | | | Silicon, 1N4152 |
| CR1462 | 152-0141-02 | | | Silicon, 1N4152 |
| CR1463 | 152-0141-02 | | | Silicon, 1N4152 |
| CR1464 | 152-0153-00 | | | Silicon, FD7003 or CD5574 |
| CR1465 | 152-0141-02 | | | Silicon, 1N4152 |
| CR1468 | 152-0141-02 | | | Silicon, 1N4152 |
| CR1472 | 152-0061-00 | | | Silicon, CD8393 or FDH2161 |
| CR1476 | 152-0061-00 | | | Silicon, CD8393 or FDH2161 |
| CR1482 | 152-0061-00 | | | Silicon, CD8393 or FDH2161 |
| CR1483 | 152-0061-00 | | | Silicon, CD8393 or FDH2161 |
| CR1487 | 152-0242-00 | | | Silicon, CD12691 |
| CR1488 | 152-0242-00 | | | Silicon, CD12691 |
| CR1511 | 152-0488-00 | | | Silicon, full wave bridge, 1.5 A, 200 V |
| CR1512 | 151-0107-00 | | | Silicon, TI60 or 1N647 |
| CR1513 | 152-0066-00 | | | Silicon, diffused, selected from 1N3194 |
| CR1514 | 152-0066-00 | | | Silicon, diffused, selected from 1N3194 |
| CR1524 | 152-0141-02 | | | Silicon, 1N4152 |
| CR1532 | 152-0061-00 | | | Silicon, CD8393 or FDH2161 |
| CR1533 | 152-0141-02 | | | Silicon, 1N4152 |
| CR1534 | 152-0066-00 | | | Silicon, diffused, selected from 1N3194 |
| CR1535 | 152-0066-00 | | | Silicon, diffused, selected from 1N3194 |
| CR1536 | 152-0141-02 | | | Silicon, 1N4152 |
| CR1541 | 152-0462-00 | | | Silicon, MDA960-3 |
| CR1549 | 152-0066-00 | | | Silicon, diffused, selected from 1N3194 |
| CR1551 | 152-0488-00 | | | Silicon, full wave bridge, 1.5 A, 200 V |
| CR1556 | 152-0141-02 | | | Silicon, 1N4152 |
| CR1559 | 152-0066-00 | | | Silicon, diffused, selected from 1N3194 |
| CR1561 | 152-0488-00 | | | Silicon, full wave bridge, 1.5 A, 200 V |
| CR1564 | 152-0141-02 | | | Silicon, 1N4152 |
| CR1569 | 152-0066-00 | | | Silicon, diffused, selected from 1N3194 |
| CR1596 | 152-0141-02 | | | Silicon, 1N4152 |
| CR1691 | 152-0141-02 | | | Silicon, 1N4152 |
| CR1692 | 152-0141-02 | | | Silicon, 1N4152 |

| Ckt. No. | Tektronix Part No. | Serial/Model No. Eff | Disc | Description |
|---------------|--------------------|----------------------|------|---|
| DIODES (cont) | | | | |
| CR1694 | 152-0141-02 | | | Silicon, 1N4152 |
| CR1696 | 152-0141-02 | | | Silicon, 1N4152 |
| CR1699 | 152-0141-02 | | | Silicon, 1N4152 |
| VR21 | 152-0166-00 | | | Zener, low impedance, selected from 1N753A |
| VR71 | 152-0166-00 | | | Zener, low impedance, selected from 1N753A |
| VR129 | 152-0166-00 | | | Zener, low impedance, selected from 1N753A |
| VR229 | 152-0166-00 | | | Zener, low impedance, selected from 1N753A |
| VR464 | 152-0195-00 | XB040000 | | Zener, selected from 1N751A, 0.4 W, 5.1 V, 5% |
| VR481 | 152-0395-00 | XB060000 | | Zener, 1N749A, 0.4 W, 4.3 V, 5% |
| VR491 | 152-0395-00 | XB060000 | | Zener, 1N749A, 0.4 W, 4.3 V, 5% |
| VR875 | 152-0278-00 | | | Zener, 1N5372A, 0.4 W, 3 V, 5% |
| VR896 | 152-0227-00 | | | Zener, low noise, selected from 1N753A |
| VR1039 | 152-0166-00 | | | Zener, low impedance, selected from 1N753A |
| VR1099 | 152-0166-00 | | | Zener, low impedance, selected from 1N753A |
| VR1145 | 152-0395-00 | | | Zener, 1N749A, 0.4 W, 4.3 V, 5% |
| VR1146 | 152-0166-00 | | | Zener, low impedance, selected from 1N753A |
| VR1155 | 152-0278-00 | | | Zener, 1N4372A, 0.4 W, 3 V, 5% |
| VR1289 | 152-0166-00 | | | Zener, low impedance, selected from 1N753A |
| VR1434 | 152-0247-00 | | | Zener, 1N989B, 0.4 W, 150 V, 5% |
| VR1441 | 152-0283-00 | | | Zener, 1N976V, 0.4 W, 43 V, 5% |
| VR1484 | 152-0286-00 | | | Zener, 1N982B, 0.4 W, 75 V, 5% |
| VR1515 | 152-0562-00 | | | Zener, 1N983, 0.4 W, 82 V, 1% |
| VR1522 | 152-0411-00 | | | Zener, 1N937, 0.25 W, 9 V, 5% |
| VR1524 | 152-0304-00 | | | Zener, 1N968B, 0.4 W, 20 V, 5% |
| VR1525 | 152-0283-00 | | | Zener, 1N976B, 0.4 W, 43 V, 5% |
| VR1533 | 152-0304-00 | | | Zener, 1N968B, 0.4 W, 20 V, 5% |
| DELAY LINE | | | | |
| DL339 | 119-0387-00 | | | Delay line |
| BULBS | | | | |
| DS382 | 150-0130-00 | | | Incandescent, 14 V, 80 mA, red dome lens |
| DS386 | 150-0130-00 | | | Incandescent, 14 V, 80 mA, red dome lens |
| DS388 | 150-0035-00 | | | Neon, AID-T, 0.3 mA |
| DS389 | 150-0035-00 | | | Neon, AID-T, 0.3 mA |
| DS392 | 150-0130-00 | | | Incandescent, 14 V, 80 mA, red dome lens |
| DS396 | 150-0130-00 | | | Incandescent, 14 V, 80 mA, red dome lens |
| DS834 | 150-0130-00 | | | Incandescent, 14 V, 80 mA, red dome lens |
| DS836 | 150-0130-00 | | | Incandescent, 14 V, 80 mA, red dome lens |
| DS1140 | 150-0035-00 | | | Neon, AID-T, 0.3 mA |
| DS1239 | 150-0035-00 | | | Neon, AID-T, 0.3 mA |
| DS1425 | 150-0002-00 | | | Neon, NE2 |
| DS1426 | 150-0002-00 | | | Neon, NE2 |
| DS1570 | 150-0129-00 | | | Incandescent, 2112, 6.3 V, 200 mA |
| DS1571 | 150-0129-00 | | | Incandescent, 2112, 6.3 V, 200 mA |
| DS1588 | 150-0130-00 | | | Incandescent, 14 V, 80 mA, red dome lens |

| Ckt. No. | Tektronix Part No. | Serial/Model No. Eff | Disc | Description |
|-------------------|--------------------|----------------------|------------------|--|
| FUSES | | | | |
| F1419 | 159-0016-00 | | | Cartridge, 1.5 A, 3AG, fast-blo |
| F1501 | 159-0016-00 | | | Cartridge, 1.5 A, 3AG, fast-blo |
| CONNECTORS | | | | |
| J1 | 136-0499-14 | | | Socket, ckt brd, 14 contact |
| J2 | 136-0499-10 | | | Socket, ckt brd, 10 contact |
| J3 | 136-0499-04 | | | Socket, ckt brd, 4 contact |
| J4 | 131-0679-00 | | | Receptacle, electrical, BNC, 3 contact |
| J5 | 136-0499-10 | | | Socket, ckt brd, 10 contact |
| J6 | 136-0499-14 | | | Socket, ckt brd, 14 contact |
| J54 | 131-0679-00 | | | Receptacle, electrical, BNC, 3 contact |
| J162 | 131-1003-00 | | | Receptacle, coaxial cable |
| J164 | 131-1003-00 | | | Receptacle, coaxial cable |
| J165 | 131-0955-00 | | | Receptacle, electrical, BNC, female |
| J168 | 131-1003-00 | | | Receptacle, coaxial cable |
| J262 | 131-1003-00 | | | Receptacle, coaxial cable |
| J338 | 131-1003-00 | | | Receptacle, coaxial cable |
| J339 | 131-1003-00 | | | Receptacle, coaxial cable |
| J349 | 131-1003-00 | | | Receptacle, coaxial cable |
| J351 | 131-1003-00 | | | Receptacle, coaxial cable |
| J359 | 131-1003-00 | | | Receptacle, coaxial cable |
| J500 | 131-0955-00 | | | Receptacle, electrical, BNC, female |
| J507 | 131-1003-00 | | | Receptacle, coaxial cable |
| J508 | 131-1003-00 | | | Receptacle, coaxial cable |
| J509 | 131-1003-00 | | | Receptacle, coaxial cable |
| J600 | 131-0955-00 | | | Receptacle, electrical, BNC, female |
| J1317 | 131-1003-00 | | | Receptacle, coaxial cable |
| J1318 | 131-0955-00 | | | Receptacle, electrical, BNC, female |
| J1319 | 131-1003-00 | | | Receptacle, coaxial cable |
| J1337 | 131-1003-00 | | | Receptacle, coaxial cable |
| J1338 | 131-0955-00 | | | Receptacle, electrical, BNC, female |
| J1450 | 131-0955-00 | | | Receptacle, electrical, BNC, female |
| INDUCTORS | | | | |
| L122 | 108-0181-01 | | XB010400 | 0.2 uH |
| L149 | 108-0181-01 | | | 0.2 uH |
| L249 | 108-0181-01 | | | 0.2 uH |
| L338 | 108-0182-00 | | | 0.3 uH |
| L339 | 108-0182-00 | | | 0.3 uH |
| L440 | 108-0370-00 | | B010100 B039999X | 0.14 uH |
| L442 | 108-0370-00 | | B010100 B039999X | 0.14 uH |
| L461 | 108-0740-00 | | B010100 B039999X | 230 nH |
| L464 | 108-0570-00 | | XB040000 | 75 uH |
| L471 | 108-0740-00 | | B010100 B039999X | 230 nH |
| L474 | 108-0570-00 | | XB040000 | 75 uH |
| L498 | 108-0440-00 | | XB040000 | 8 uH |

Electrical Parts List-465

| Ckt. No. | Tektronix Part No. | Serial/Model No. Eff | Disc | Description |
|-------------------------|--------------------|----------------------|----------|---|
| INDUCTORS (cont) | | | | |
| L499 | 108-0440-00 | XB040000 | | 8 uH |
| L546 | 108-0370-00 | | | 0.14 uH |
| L547 | 108-0370-00 | | | 0.14 uH |
| L646 | 108-0370-00 | | | 0.14 uH |
| L647 | 108-0370-00 | | | 0.14 uH |
| L874 | 108-0538-00 | | | 2.7 uH |
| L891 | 108-0538-00 | | | 2.7 uH |
| L893 | 108-0538-00 | | | 2.7 uH |
| L897 | 108-0538-00 | | | 2.7 uH |
| L1419 | 108-0422-00 | | | 80 uH |
| L1440 | 108-0713-00 | | | Trace rotation |
| L1446 | 108-0714-00 | | | Y axis alignment |
| L1596 | 108-0245-00 | | | 3.9 uH |
| LR122 | 108-0282-00 | XB010250 | B010379X | 0.13 uH (wound on a 30 ohm, 1/8 W, 5%, resistor) |
| LR461 | 108-0284-00 | B010100 | B039999X | 100 nH |
| LR471 | 108-0284-00 | B010100 | B039999X | 100 nH |
| LR483 | 108-0328-00 | XB040000 | | 0.3 uH |
| LR493 | 108-0328-00 | XB040000 | | 0.3 uH |
| TRANSISTORS | | | | |
| Q20A,B | 151-1032-00 | | | Silicon, JFET, N channel, 2N5911, dual |
| Q32 | 151-0259-00 | | | Silicon, NPN, selected from 2N3563 |
| Q36 | 151-0259-00 | | | Silicon, NPN, selected from 2N3563 |
| Q42 | 151-0221-00 | | | Silicon, PNP, 2N4258 |
| Q44 | 151-0221-00 | | | Silicon, PNP, 2N4258 |
| Q70A,B | 151-1032-00 | | | Silicon, JFET, N channel, 2N5911, dual |
| Q82 | 151-0259-00 | | | Silicon, NPN, selected from 2N3563 |
| Q86 | 151-0259-00 | | | Silicon, NPN, selected from 2N3563 |
| Q92 | 151-0221-00 | | | Silicon, PNP, 2N4258 |
| Q94 | 151-0221-00 | | | Silicon, PNP, 2N4258 |
| Q102 | 151-0259-00 | B010100 | B010349 | Silicon, NPN, selected from 2N3563 |
| Q102 | 151-0427-00 | B010350 | | Silicon, NPN, selected from 2N3563 |
| Q104 | 151-0259-00 | B010100 | B010349 | Silicon, NPN, selected from 2N3563 |
| Q104 | 151-0427-00 | B010350 | | Silicon, NPN, selected from 2N3563 |
| Q122 | 151-0198-00 | | | Silicon, NPN, MPS918 |
| Q124 | 151-0198-00 | | | Silicon, NPN, MPS918 |
| Q132 ¹ | 151-0271-00 | B010100 | B010199 | Silicon, PNP, SAB4113 |
| Q132 ¹ | 153-0609-00 | B010200 | | Silicon, PNP, selected from 151-0271-00, matched pair |
| Q134 ¹ | 151-0271-00 | B010100 | B010199 | Silicon, PNP, SAB4113 |
| Q134 ¹ | 153-0609-00 | B010200 | | Silicon, PNP, selected from 151-0271-00, matched pair |
| Q142 | 151-0271-00 | | | Silicon, PNP, SAB4113 |
| Q148 | 151-0271-00 | | | Silicon, PNP, SAB4113 |
| Q152 | 151-0221-00 | | | Silicon, PNP, 2N4258 |

¹Furnished as a matched pair.

| Ckt. No. | Tektronix Part No. | Serial/Model No. Eff | Disc | Description |
|--------------------|--------------------|----------------------|---------|--|
| TRANSISTORS (cont) | | | | |
| Q162 | 151-0221-00 | | | Silicon, PNP, 2N4258 |
| Q164 | 151-0221-00 | | | Silicon, PNP, 2N4258 |
| Q168 | 151-0190-01 | | | Silicon, NPN, 2N3904 or TE3904 |
| Q202 | 151-0259-00 | B010100 | B010349 | Silicon, NPN, selected from 2N3563 |
| Q202 | 151-0427-00 | B010350 | | Silicon, NPN, selected from 2N3563 |
| Q204 | 151-0259-00 | B010100 | B010349 | Silicon, NPN, selected from 2N3563 |
| Q204 | 151-0427-00 | B010350 | | Silicon, NPN, selected from 2N3563 |
| Q222 | 153-0547-00 | | | Silicon, NPN, selected from 151-0198-00, |
| Q224 | | | | matched pair |
| Q226 | 153-0547-00 | | | Silicon, NPN, selected from 151-0198-00, |
| Q228 | | | | matched pair |
| Q232 | 151-0271-00 | B010100 | B010199 | Silicon, PNP, SAB4113 |
| Q232 ¹ | 153-0609-00 | B010200 | | Silicon, PNP, selected from 151-0271-00, |
| | | | | matched pair |
| Q234 | 151-0271-00 | B010100 | B010199 | Silicon, PNP, SAB4113 |
| Q234 ¹ | 153-0609-00 | B010200 | | Silicon, PNP, selected from 151-0271-00, |
| | | | | matched pair |
| Q242 | 151-0271-00 | | | Silicon, PNP, SAB4113 |
| Q248 | 151-0271-00 | | | Silicon, PNP, SAB4113 |
| Q252 | 151-0221-00 | | | Silicon, PNP, 2N4258 |
| Q262 | 151-0221-00 | | | Silicon, PNP, 2N4258 |
| Q304 | 151-0221-00 | | | Silicon, PNP, 2N4258 |
| Q308 | 151-0221-00 | | | Silicon, PNP, 2N4258 |
| Q314 | 151-0221-00 | | | Silicon, PNP, 2N4258 |
| Q318 | 151-0221-00 | | | Silicon, PNP, 2N4258 |
| Q322 | 151-0269-00 | | | Silicon, NPN, SE3005 |
| Q324 | 151-0269-00 | | | Silicon, NPN, SE3005 |
| Q332 | 151-0188-00 | | | Silicon, PNP, 2N3906 |
| Q344 | 151-0367-00 | | | Silicon, NPN, SKA6516 |
| Q346 | 151-0221-00 | | | Silicon, PNP, 2N4258 |
| Q352 | 151-0223-00 | | | Silicon, NPN, 2N4275 |
| Q358 | 151-0223-00 | | | Silicon, NPN, 2N4275 |
| Q364 | 151-0190-01 | | | Silicon, NPN, 2N3904 or TE3904 |
| Q374 | 151-0190-01 | | | Silicon, NPN, 2N3904 or TE3904 |
| Q382 | 151-0219-00 | | | Silicon, PNP, 2N4250 |
| Q386 | 151-0219-00 | | | Silicon, PNP, 2N4250 |
| Q392 | 151-0219-00 | | | Silicon, PNP, 2N4250 |
| Q396 | 151-0219-00 | | | Silicon, PNP, 2N4250 |
| Q402 | 151-0212-00 | XB040000 | | Silicon, NPN, selected from A485 |
| Q406 | 151-0212-00 | XB040000 | | Silicon, NPN, selected from A485 |
| Q412 | 151-0212-00 | XB040000 | | Silicon, NPN, selected from A485 |
| Q416 | 151-0212-00 | XB040000 | | Silicon, NPN, selected from A485 |
| Q432 | 151-0212-00 | XB040000 | | Silicon, NPN, selected from A485 |
| Q442 | 151-0212-00 | XB040000 | | Silicon, NPN, selected from A485 |
| Q462 | 151-0434-00 | XB040000 | | Silicon, PNP, 2N4261 |

¹Furnished as a matched pair.

| Ckt. No. | Tektronix Part No. | Serial/Model No. Eff | Disc | Description |
|--------------------|--------------------|----------------------|---------|--|
| TRANSISTORS (cont) | | | | |
| Q468 | 151-0222-00 | XB040000 | | Silicon, NPN, selected from 2N4217 |
| Q472 | 151-0434-00 | XB040000 | | Silicon, PNP, 2N4261 |
| Q478 | 151-0222-00 | XB040000 | | Silicon, NPN, selected from 2N4217 |
| Q482 | 151-0446-00 | XB040000 | | Silicon, NPN, 2N3866 |
| Q492 | 151-0446-00 | XB040000 | | Silicon, NPN, 2N3866 |
| Q522 ¹ | 151-1042-00 | | | Silicon, JFET, N channel, 2N5245, pair |
| Q524 ¹ | | | | |
| Q550 | 151-0221-00 | | | Silicon, PNP, 2N4258 |
| Q552 | 151-0221-00 | | | Silicon, PNP, 2N4258 |
| Q622 ¹ | 151-1042-00 | | | Silicon, JFET, N channel, 2N5245, pair |
| Q624 ¹ | | | | |
| Q650 | 151-0221-00 | | | Silicon, PNP, 2N4258 |
| Q652 | 151-0221-00 | | | Silicon, PNP, 2N4258 |
| Q672 ¹ | 151-0369-00 | B010100 | B010359 | Silicon, PNP, replaceable by 151-0271-00 |
| Q672 ¹ | 151-0221-00 | B010360 | B010399 | Silicon, PNP, 2N4258 |
| Q672 | 153-0597-00 | B010400 | | Silicon, PNP, 2N4258 |
| Q678 | 151-0367-00 | | | Silicon, NPN, SKA6516 |
| Q682 | 151-0369-00 | B010100 | B010359 | Silicon, PNP, replaceable by 151-0271-00 |
| Q682 ¹ | 151-0221-00 | B010360 | B010399 | Silicon, PNP, 2N4258 |
| Q682 ¹ | 153-0597-00 | B010400 | | Silicon, PNP, 2N4258 |
| Q688 | 151-0367-00 | | | Silicon, NPN, SKA6516 |
| Q804 | 151-0220-00 | | | Silicon, PNP, 2N4122 |
| Q812 | 151-0220-00 | | | Silicon, PNP, 2N4122 |
| Q814 | 151-0220-00 | | | Silicon, PNP, 2N4122 |
| Q822 | 151-0220-00 | | | Silicon, PNP, 2N4122 |
| Q824 | 151-0220-00 | | | Silicon, PNP, 2N4122 |
| Q828 | 151-0190-01 | | | Silicon, NPN, 2N3904 or TE3904 |
| Q854 | 151-0220-00 | | | Silicon, PNP, 2N4122 |
| Q862 | 151-0220-00 | | | Silicon, PNP, 2N4122 |
| Q864 | 151-0220-00 | | | Silicon, PNP, 2N4122 |
| Q1002 | 151-0354-00 | | | Silicon, PNP, QD400 |
| Q1012 | 151-0220-00 | | | Silicon, PNP, 2N4122 |
| Q1014 | 151-0220-00 | | | Silicon, PNP, 2N4122 |
| Q1024 | 151-0283-00 | | | Silicon, NPN, selected from 2N3933 |
| Q1030 | 151-1025-00 | | | Silicon, JFET, N channel similar to KE4416 |
| Q1036 | 151-0127-00 | | | Silicon, NPN, selected from 2N2369 |
| Q1038 | 151-0188-00 | | | Silicon, PNP, 2N3906 |
| Q1042A,B | 151-0232-00 | | | Silicon, NPN, replaceable by 2N2919, dual |
| Q1044 | 151-0190-01 | | | Silicon, NPN, 2N3904 or TE3904 |
| Q1052 | 151-0220-00 | | | Silicon, PNP, 2N4122 |
| Q1054 | 151-0220-00 | | | Silicon, PNP, 2N4122 |
| Q1062 | 151-0354-00 | | | Silicon, PNP, QD400 |
| Q1063 | 151-0188-00 | | | Silicon, PNP, 2N3906 |
| Q1072 | 151-0220-00 | | | Silicon, PNP, 2N4122 |
| Q1074 | 151-0220-00 | | | Silicon, PNP, 2N4122 |

¹Furnished as a matched pair.

| Ckt. No. | Tektronix Part No. | Serial/Model No. Eff | No. Disc | Description |
|--------------------|--------------------|----------------------|----------|---|
| TRANSISTORS (cont) | | | | |
| Q1084 | 151-0283-00 | | | Silicon, NPN, selected from 2N3933 |
| Q1090 | 151-1025-00 | | | Silicon, JFET, N channel, similar to KE4416 |
| Q1096 | 151-0127-00 | | | Silicon, NPN, selected from 2N2369 |
| Q1098 | 151-0188-00 | | | Silicon, PNP, 2N3906 |
| Q1140 | 151-0302-00 | | | Silicon, NPN, 2N2222A |
| Q1170 | 151-0302-00 | | | Silicon, NPN, 2N2222A |
| Q1214 | 151-0220-00 | | | Silicon, PNP, 2N4122 |
| Q1218 | 151-0216-00 | | | Silicon, PNP, MPS6523 |
| Q1224 | 151-0190-02 | | | Silicon, NPN, 2N3904 |
| Q1226 | 151-0188-00 | | | Silicon, PNP, 2N3906 |
| Q1234 | 151-0190-02 | | | Silicon, NPN, 2N3904 |
| Q1236 | 151-0188-00 | | | Silicon, PNP, 2N3906 |
| Q1244 | 151-0302-00 | | | Silicon, NPN, 2N2222A |
| Q1254 | 151-0301-00 | | | Silicon, PNP, 2N2907 |
| Q1262 | 151-0406-00 | | | Silicon, PNP, selected from 2N3495 |
| Q1266 | 151-0407-00 | | | Silicon, NPN, Tek Spec |
| Q1274 | 151-0302-00 | | | Silicon, NPN, 2N2222A |
| Q1282 | 151-0406-00 | | | Silicon, PNP, selected from 2N3495 |
| Q1286 | 151-0407-00 | | | Silicon, NPN, Tek Spec |
| Q1304 | 151-0190-01 | | | Silicon, NPN, 2N3940 or TE3904 |
| Q1306 | 151-0190-01 | | | Silicon, NPN, 2N3904 or TE3904 |
| Q1314 | 151-0220-00 | | | Silicon, PNP, 2N4122 |
| Q1324 | 151-0190-01 | | | Silicon, NPN, 2N3904 or TE3904 |
| Q1326 | 151-0190-01 | | | Silicon, NPN, 2N3904 or TE3904 |
| Q1334 | 151-0220-00 | | | Silicon, PNP, 2N4122 |
| Q1404 | 151-0126-00 | | | Silicon, NPN, 2N2484 |
| Q1408 | 151-0301-00 | | | Silicon, PNP, 2N2907 |
| Q1413 | 151-0188-00 | | | Silicon, PNP, 2N3906 |
| Q1414 | 151-0190-01 | | | Silicon, NPN, 2N3904 or TE3904 |
| Q1416 | 151-0136-00 | | | Silicon, NPN, 2N3053 |
| Q1418 | 151-0140-00 | | | Silicon, NPN, selected from 2N3055 |
| Q1466 | 151-0223-00 | | | Silicon, NPN, 2N4275 |
| Q1472 | 151-0188-00 | | | Silicon, PNP, 2N3906 |
| Q1474 | 151-0407-00 | | | Silicon, NPN, Tek Spec |
| Q1478 | 151-0406-00 | | | Silicon, PNP, selected from 2N3495 |
| Q1514 | 151-0506-00 | | | SCR, 200 V, 4A, C106B2 |
| Q1532 | 151-0347-00 | | | Silicon, NPN, 2N5551 |
| Q1534 | 151-0349-00 | | | Silicon, NPN, replaceable by MJE2801 |
| Q1536 | 151-0347-00 | | | Silicon, NPN, 2N5551 |
| Q1544 | 151-0302-00 | | | Silicon, NPN, 2N2222A |
| Q1546 | 151-0349-00 | | | Silicon, NPN, replaceable by MJE2801 |
| Q1548 | 151-0302-00 | | | Silicon, NPN, 2N2222A |
| Q1556 | 151-0390-00 | | | Silicon, NPN, Darlington, MPSU45 |
| Q1558 | 151-0302-00 | | | Silicon, NPN, 2N2222A |
| Q1564 | 151-0302-00 | | | Silicon, NPN, 2N2222A |

| Ckt. No. | Tektronix Part No. | Serial/Model No. Eff | Disc | Description |
|--------------------|--------------------|----------------------|----------|--------------------------------------|
| TRANSISTORS (cont) | | | | |
| Q1566 | 151-0349-00 | | | Silicon, NPN, replaceable by MJE2801 |
| Q1568 | 151-0302-00 | | | Silicon, NPN, 2N2222A |
| Q1570 | 151-0390-00 | | | Silicon, NPN, Darlington, MPSU45 |
| Q1582 | 151-0302-00 | | | Silicon, NPN, 2N2222A |
| Q1588 | 151-0302-00 | | | Silicon, NPN, 2N2222A |
| Q1590 | 151-0342-00 | | | Silicon, PNP, 2N4249 |
| Q1594 | 151-0342-00 | | | Silicon, PNP, 2N4249 |
| Q1598 | 151-0164-00 | | | Silicon, PNP, 2N5447 or 2N3702 |
| Q1698 | 151-0301-00 | | | Silicon, PNP, 2N2907 |
| RESISTORS | | | | |
| R1 | 315-0510-00 | | | 51 ohm, 1/4 W, 5% |
| R3 | 307-0110-00 | B010100 | B011071 | 3 ohm, 1/4 W, 5% |
| R3 | 317-0047-00 | B011072 | | 4.7 ohm, 1/8 W, 5% |
| R4 | 316-0105-00 | | | 1M ohm, 1/4 W, 10% |
| R6 | 316-0101-00 | B010100 | B010299 | 100 ohm, 1/4 W, 10% |
| R6 | 317-0101-00 | B010300 | | 100 ohm, 1/8 W, 5% |
| R15 | 321-0481-00 | | | 1M ohm, 1/8 W, 1% |
| R16 | 316-0474-00 | | | 470K ohm, 1/4 W, 10% |
| R18 | 315-0331-00 | | | 330 ohm, 1/4 W, 5% |
| R21 | 315-0151-00 | | | 150 ohm, 1/4 W, 5% |
| R22 | 321-0030-02 | | | 20 ohm, 1/8 W, 1/2% |
| R23 | 321-0030-02 | | | 20 ohm, 1/8 W, 1/2% |
| R25 | 311-1227-00 | | | 5K ohm, Var |
| R26 | 315-0123-00 | | | 12K ohm, 1/4 W, 5% |
| R27 | 315-0151-00 | | | 150 ohm, 1/4 W, 5% |
| R32 | 321-0208-00 | | | 1.43K ohm, 1/8 W, 1% |
| R33 | 321-0097-00 | | | 100 ohm, 1/8 W, 1% |
| R34 | 315-0434-00 | B010100 | B039999X | 430K ohm, 1/4 W, 5% |
| R35 | 315-0104-00 | | | 100K ohm, 1/4 W, 5% |
| R36 | 321-0208-00 | | | 1.43K ohm, 1/8 W, 1% |
| R37 | 315-0621-00 | | | 620 ohm, 1/4 W, 5% |
| R38 | 315-0621-00 | | | 620 ohm, 1/4 W, 5% |
| R39 | 316-0101-00 | | | 100 ohm, 1/4 W, 10% |
| RT39 | 307-0124-00 | | | 5K ohm, Thermal |
| R41 | 321-0190-00 | | | 931 ohm, 1/8 W, 1% |
| R42 | 316-0101-00 | | | 100 ohm, 1/4 W, 10% |
| R43 | 321-0190-00 | | | 931 ohm, 1/8 W, 1% |
| R44 | 321-0098-01 | | | 102 ohm, 1/8 W, 1/2% |
| R45 | 321-0098-01 | | | 102 ohm, 1/8 W, 1/2% |
| R46 | 321-0126-01 | | | 200 ohm, 1/8 W, 1/2% |
| R47 | 311-0635-00 | | | 1K ohm, Var |
| R48 | 311-0635-00 | | | 1K ohm, Var |
| R49 | 321-0080-00 | B010100 | B010799 | 66.5 ohm, 1/8 W, 1% |
| R49 | 321-0080-01 | B010800 | | 66.5 ohm, 1/8 W, 1/2% |
| R51 | 315-0510-00 | | | 51 ohm, 1/4 W, 5% |

| Ckt. No. | Tektronix Part No. | Serial/Model No. Eff | Disc | Description |
|-------------------|--------------------|----------------------|----------|-----------------------|
| RESISTORS (cont) | | | | |
| R53 | 307-0110-00 | B010100 | B011071 | 3 ohm, 1/4 W, 5% |
| R53 | 317-0047-00 | B011072 | | 4.7 ohm, 1/8 W, 5% |
| R54 | 316-0105-00 | | | 1M ohm, 1/4 W, 10% |
| R56 | 316-0101-00 | B010100 | B010299 | 100 ohm, 1/4 W, 10% |
| R56 | 317-0101-00 | B010300 | | 100 ohm, 1/8 W, 5% |
| R65 | 321-0481-00 | | | 1M ohm, 1/8 W, 1% |
| R66 | 316-0474-00 | | | 470K ohm, 1/4 W, 10% |
| R68 | 315-0331-00 | | | 330 ohm, 1/4 W, 5% |
| R71 | 315-0151-00 | | | 150 ohm, 1/4 W, 5% |
| R72 | 321-0030-02 | | | 20 ohm, 1/8 W, 1/2% |
| R73 | 321-0030-02 | | | 20 ohm, 1/8 W, 1/2% |
| R75 | 311-1227-00 | | | 5K ohm, Var |
| R76 | 315-0123-00 | | | 12K ohm, 1/4 W, 5% |
| R77 | 315-0151-00 | | | 150 ohm, 1/4 W, 5% |
| R82 | 321-0208-00 | | | 1.43K ohm, 1/8 W, 1% |
| R83 | 321-0097-00 | | | 100 ohm, 1/8 W, 1% |
| R84 | 315-0434-00 | B010100 | B039999X | 430K ohm, 1/4 W, 5% |
| R85 | 315-0104-00 | | | 100K ohm, 1/4 W, 5% |
| R86 | 321-0208-00 | | | 1.43K ohm, 1/8 W, 1% |
| R87 | 315-0621-00 | | | 620 ohm, 1/4 W, 5% |
| R88 | 315-0621-00 | | | 620 ohm, 1/4 W, 5% |
| R91 | 321-0190-00 | | | 931 ohm, 1/8 W, 1% |
| R92 | 316-0101-00 | | | 100 ohm, 1/4 W, 10% |
| R93 | 321-0190-00 | | | 931 ohm, 1/8 W, 1% |
| R94 | 321-0098-01 | | | 102 ohm, 1/8 W, 1/2% |
| R95 | 321-0098-01 | | | 102 ohm, 1/8 W, 1/2% |
| R96 | 321-0126-01 | | | 200 ohm, 1/8 W, 1/2% |
| R97 | 311-0635-00 | | | 1K ohm, Var |
| R98 | 311-0635-00 | | | 1K ohm, Var |
| R99 | 321-0080-00 | B010100 | B010799 | 66.5 ohm, 1/8 W, 1% |
| R99 | 321-0080-01 | B010800 | | 66.5 ohm, 1/8 W, 1/2% |
| R101 | 315-0682-00 | | | 6.8K ohm, 1/4 W, 5% |
| R102 | 321-0204-00 | | | 1.3K ohm, 1/8 W, 1% |
| R103 | 321-0087-00 | | | 78.7 ohm, 1/8 W, 1% |
| R104 | 321-0204-00 | | | 1.3K ohm, 1/8 W, 1% |
| R105 | 311-1225-00 | B010100 | B010264 | 1K ohm, Var |
| R105 | 311-1226-00 | B010265 | | 2.5K ohm, Var |
| R106 | 315-0301-00 | | | 300 ohm, 1/4 W, 5% |
| R107 | 315-0270-00 | | | 27 ohm, 1/4 W, 5% |
| R108 | 315-0301-00 | | | 300 ohm, 1/4 W, 5% |
| R109 | 315-0270-00 | | | 27 ohm, 1/4 W, 5% |
| R111 | 321-0026-00 | | | 18.2 ohm, 1/8 W, 1% |
| R112 ¹ | 311-1371-00 | B010100 | B010399 | 1K ohm, Var |
| R112 ¹ | 311-1364-00 | B010400 | | 1K ohm, Var |
| R113 | 321-0026-00 | | | 18.2 ohm, 1/8 W, 1% |

¹Furnished as a unit with S112.

| Ckt. No. | Tektronix Part No. | Serial/Model No. Eff | Disc | Description |
|------------------|--------------------|----------------------|---------|----------------------|
| RESISTORS (cont) | | | | |
| R114 | 315-0103-00 | | | 10K ohm, 1/4 W, 5% |
| R115 | 311-1228-00 | | | 10K ohm, Var |
| R117 | 321-0085-00 | | | 75 ohm, 1/8 W, 1% |
| R118 | 311-1225-00 | | | 1K ohm, Var |
| R119 | 321-0085-00 | | | 75 ohm, 1/8 W, 1% |
| R120 | 311-1007-00 | XB010200 | | 20 ohm, Var |
| R121 | 321-0064-00 | | | 45.3 ohm, 1/8 W, 1% |
| R122 | 311-0634-00 | XB010250 | | 500 ohm, Var |
| R123 | 321-0064-00 | B010100 | B010199 | 45.3 ohm, 1/8 W, 1% |
| R123 | 321-0055-00 | B010200 | | 36.5 ohm, 1/8 W, 1% |
| R125 | 316-0101-00 | | | 100 ohm, 1/4 W, 10% |
| R127 | 321-0122-00 | | | 182 ohm, 1/8 W, 1% |
| R128 | 321-0122-00 | | | 182 ohm, 1/8 W, 1% |
| R130 | 321-0138-00 | | | 267 ohm, 1/8 W, 1% |
| RT131 | 307-0124-00 | | | 5K ohm, Thermal |
| R132 | 321-0198-00 | | | 1.13K ohm, 1/8 W, 1% |
| R133 | 321-0097-00 | | | 100 ohm, 1/8 W, 1% |
| R134 | 321-0198-00 | | | 1.13K ohm, 1/8 W, 1% |
| R135 | 316-0101-00 | | | 100 ohm, 1/4 W, 10% |
| R136 | 315-0621-00 | | | 620 ohm, 1/4 W, 5% |
| R137 | 316-0101-00 | | | 100 ohm, 1/4 W, 10% |
| R138 | 315-0621-00 | | | 620 ohm, 1/4 W, 5% |
| R141 | 316-0390-00 | | | 39 ohm, 1/4 W, 10% |
| R142 | 315-0391-00 | | | 390 ohm, 1/4 W, 5% |
| R143 | 321-0200-00 | | | 1.18K ohm, 1/8 W, 1% |
| R144 | 321-0084-00 | | | 73.2 ohm, 1/8 W, 1% |
| R145 | 315-0100-00 | | | 10 ohm, 1/4 W, 5% |
| R146 | 321-0200-00 | | | 1.18K ohm, 1/8 W, 1% |
| R147 | 316-0390-00 | | | 39 ohm, 1/4 W, 10% |
| R149 | 311-1225-00 | | | 1K ohm, Var |
| R151 | 315-0331-00 | | | 330 ohm, 1/4 W, 5% |
| R152 | 321-0160-00 | | | 453 ohm, 1/8 W, 1% |
| R154 | 321-0201-00 | | | 1.21K ohm, 1/8 W, 1% |
| R155 | 311-1224-00 | | | 500 ohm, Var |
| R161 | 315-0331-00 | | | 330 ohm, 1/4 W, 5% |
| R162 | 321-0064-00 | | | 45.3 ohm, 1/8 W, 1% |
| R164 | 315-0751-00 | | | 750 ohm, 1/4 W, 5% |
| R168 | 321-0064-00 | | | 45.3 ohm, 1/8 W, 1% |
| R169 | 316-0101-00 | | | 100 ohm, 1/4 W, 10% |
| R201 | 315-0562-00 | | | 5.6K ohm, 1/4 W, 5% |
| R202 | 321-0204-00 | | | 1.3K ohm, 1/8 W, 1% |
| R203 | 321-0087-00 | | | 78.7 ohm, 1/8 W, 1% |
| R204 | 321-0204-00 | | | 1.3K ohm, 1/8 W, 1% |
| R205 | 311-1225-00 | B010100 | B010264 | 1K ohm, Var |
| R205 | 311-1226-00 | B010265 | | 2.5K ohm, Var |

| Ckt. No. | Tektronix Part No. | Serial/Model No. Eff | Disc | Description |
|-------------------|--------------------|----------------------|---------|----------------------|
| RESISTORS (cont) | | | | |
| R206 | 315-0301-00 | | | 300 ohm, 1/4 W, 5% |
| R207 | 315-0270-00 | | | 27 ohm, 1/4 W, 5% |
| R208 | 315-0301-00 | | | 300 ohm, 1/4 W, 5% |
| R209 | 315-0270-00 | | | 27 ohm, 1/4 W, 5% |
| R211 | 321-0026-00 | | | 18.2 ohm, 1/8 W, 1% |
| R212 ¹ | 311-1371-00 | B010100 | B010399 | 1K ohm, Var |
| R212 ¹ | 311-1364-00 | B010400 | | 1K ohm, Var |
| R213 | 321-0026-00 | | | 18.2K ohm, 1/8 W, 1% |
| R214 | 315-0103-00 | | | 10K ohm, 1/4 W, 5% |
| R215 | 311-1228-00 | | | 10K ohm, Var |
| R217 | 321-0085-00 | | | 75 ohm, 1/8 W, 1% |
| R218 | 311-1225-00 | | | 1K ohm, Var |
| R219 | 321-0085-00 | | | 75 ohm, 1/8 W, 1% |
| R220 | 311-1007-00 | XB010200 | | 20 ohm, Var |
| R221 | 321-0064-00 | | | 45.3 ohm, 1/8 W, 1% |
| R222 | 316-0101-00 | | | 100 ohm, 1/4 W, 10% |
| R223 | 321-0064-00 | B010100 | B010199 | 45.3 ohm, 1/8 W, 1% |
| R223 | 321-0055-00 | B010200 | | 36.5 ohm, 1/8 W, 1% |
| R224 | 316-0103-00 | | | 10K ohm, 1/4 W, 10% |
| R225 | 316-0103-00 | | | 10K ohm, 1/4 W, 10% |
| R226 | 316-0103-00 | | | 10K ohm, 1/4 W, 10% |
| R227 | 321-0122-00 | | | 182 ohm, 1/8 W, 1% |
| R228 | 321-0122-00 | | | 182 ohm, 1/8 W, 1% |
| R229 | 316-0101-00 | | | 100 ohm, 1/4 W, 10% |
| R230 | 321-0138-00 | | | 267 ohm, 1/8 W, 1% |
| RT231 | 307-0124-00 | | | 5K ohm, Thermal |
| R232 | 321-0198-00 | | | 1.13K ohm, 1/8 W, 1% |
| R233 | 321-0097-00 | | | 100 ohm, 1/8 W, 1% |
| R234 | 321-0198-00 | | | 1.13K ohm, 1/8 W, 1% |
| R235 | 316-0101-00 | | | 100 ohm, 1/4 W, 10% |
| R236 | 315-0621-00 | | | 620 ohm, 1/4 W, 5% |
| R237 | 316-0101-00 | | | 100 ohm, 1/4 W, 10% |
| R238 | 315-0621-00 | | | 620 ohm, 1/4 W, 5% |
| R241 | 316-0390-00 | | | 39 ohm, 1/4 W, 10% |
| R242 | 315-0391-00 | | | 390 ohm, 1/4 W, 5% |
| R243 | 321-0200-00 | | | 1.18K ohm, 1/8 W, 1% |
| R244 | 321-0084-00 | | | 73.2 ohm, 1/8 W, 1% |
| R245 | 315-0270-00 | | | 27 ohm, 1/4 W, 5% |
| R246 | 321-0200-00 | | | 1.18K ohm, 1/8 W, 1% |
| R247 | 316-0390-00 | | | 39 ohm, 1/4 W, 10% |
| R249 | 311-1225-00 | | | 1K ohm, Var |
| R251 | 315-0331-00 | | | 330 ohm, 1/4 W, 5% |
| R252 | 321-0160-00 | | | 453 ohm, 1/8 W, 1% |
| R254 | 321-0201-00 | | | 1.21K ohm, 1/8 W, 1% |
| R255 | 311-1224-00 | | | 500 ohm, Var |

¹Furnished as a unit with S212.

| Ckt. No. | Tektronix Part No. | Serial/Model No. Eff | Disc | Description |
|------------------|--------------------|----------------------|----------|----------------------|
| RESISTORS (cont) | | | | |
| R261 | 315-0751-00 | | | 750 ohm, 1/4 W, 5% |
| R262 | 321-0064-00 | | | 45.3 ohm, 1/8 W, 1% |
| R301 | 311-1311-00 | | | 1K ohm, Var |
| R302 | 321-0236-00 | | | 2.8K ohm, 1/8 W, 1% |
| R311 | 311-1311-00 | | | 1K ohm, Var |
| R312 | 321-0236-00 | | | 2.8K ohm, 1/8 W, 1% |
| R321 | 321-0186-00 | | | 845 ohm, 1/8 W, 1% |
| R322 | 321-0186-00 | | | 845 ohm, 1/8 W, 1% |
| R323 | 321-0157-00 | | | 422 ohm, 1/8 W, 1% |
| R324 | 321-0157-00 | | | 422 ohm, 1/8 W, 1% |
| R325 | 321-0114-00 | | | 150 ohm, 1/8 W, 1% |
| R326 | 323-0175-00 | | | 649 ohm, 1/2 W, 1% |
| R327 | 321-0114-00 | | | 150 ohm, 1/8 W, 1% |
| R331 | 323-0124-00 | | | 191 ohm, 1/2 W, 1% |
| R332 | 316-0221-00 | | | 220 ohm, 1/4 W, 10% |
| R334 | 316-0391-00 | | | 390 ohm, 1/4 W, 10% |
| R335 | 321-0065-00 | | | 46.4 ohm, 1/8 W, 1% |
| R336 | 321-0065-00 | | | 46.4 ohm, 1/8 W, 1% |
| R340 | 311-1222-00 | | | 100 ohm, Var |
| R341 | 323-0168-00 | | | 549 ohm, 1/2 W, 1% |
| R342 | 321-0041-00 | | | 26.1 ohm, 1/8 W, 1% |
| R343 | 315-0101-00 | | | 100 ohm, 1/4 W, 5% |
| R344 | 321-0093-00 | | | 90.9 ohm, 1/8 W, 1% |
| R345 | 321-0197-00 | | | 1.1K ohm, 1/8 W, 1% |
| R346 | 321-0164-00 | | | 499 ohm, 1/8 W, 1% |
| R347 | 321-0095-00 | | | 95.3 ohm, 1/8 W, 1% |
| R348 | 321-0114-00 | | | 150 ohm, 1/8 W, 1% |
| R349 | 321-0068-00 | | | 49.9 ohm, 1/8 W, 1% |
| R351 | 315-0752-00 | | | 7.5K ohm, 1/4 W, 5% |
| R352 | 321-0089-00 | | | 82.5 ohm, 1/8 W, 1% |
| R356 | 315-0683-00 | | | 68K ohm, 1/4 W, 5% |
| R357 | 316-0101-00 | | | 100 ohm, 1/4 W, 10% |
| R358 | 315-0202-00 | | | 2K ohm, 1/4 W, 5% |
| R359 | 315-0272-00 | | | 2.7K ohm, 1/4 W, 5% |
| R361 | 321-0193-00 | | | 1K ohm, 1/8 W, 1% |
| R362 | 321-0158-00 | | | 432 ohm, 1/8 W, 1% |
| R364 | 321-0212-00 | | | 1.58K ohm, 1/8 W, 1% |
| R365 | 321-0229-00 | | | 2.37K ohm, 1/8 W, 1% |
| R367 | 315-0201-00 | | | 200 ohm, 1/4 W, 5% |
| R368 | 321-0122-00 | | | 182 ohm, 1/8 W, 1% |
| R370 | 315-0123-00 | | | 12K ohm, 1/4 W, 5% |
| R371 | 321-0193-00 | | | 1K ohm, 1/8 W, 1% |
| R372 | 321-0158-00 | | | 432 ohm, 1/8 W, 1% |
| R374 | 321-0212-00 | | | 1.58K ohm, 1/8 W, 1% |
| R375 | 321-0229-00 | | | 2.37K ohm, 1/8 W, 1% |
| | | | XB010350 | |

| Ckt. No. | Tektronix Part No. | Serial/Model No. Eff | Disc | Description |
|------------------|--------------------|----------------------|----------|------------------------------------|
| RESISTORS (cont) | | | | |
| R376 | 315-0201-00 | | | 200 ohm, 1/4 W, 5% |
| R378 | 321-0122-00 | | | 182 ohm, 1/8 W, 1% |
| R381 | 316-0152-00 | | | 1.5K ohm, 1/4 W, 10% |
| R383 | 316-0222-00 | | | 2.2K ohm, 1/4 W, 10% |
| R384 | 316-0822-00 | | | 8.2K ohm, 1/4 W, 10% |
| R386 | 316-0223-00 | | | 22K ohm, 1/4 W, 10% |
| R388 | 316-0154-00 | | | 150K ohm, 1/4 W, 10% |
| R389 | 316-0154-00 | | | 150K ohm, 1/4 W, 10% |
| R391 | 316-0152-00 | | | 1.5K ohm, 1/4 W, 10% |
| R393 | 316-0222-00 | | | 2.2K ohm, 1/4 W, 10% |
| R394 | 316-0822-00 | | | 8.2K ohm, 1/4 W, 10% |
| R396 | 316-0223-00 | | | 22K ohm, 1/4 W, 10% |
| R400 | 311-1139-00 | B010100 | B039999X | 500 ohm, Var |
| R401 | 321-0068-00 | | | 49.9 ohm, 1/8 W, 1% |
| R402 | 321-0104-00 | B010100 | B039999 | 118 ohm, 1/8 W, 1% |
| R402 | 315-0221-00 | B040000 | | 220 ohm, 1/4 W, 5% |
| R403 | 315-0390-00 | B010100 | B039999 | 39 ohm, 1/4 W, 5% |
| R403 | 321-0097-00 | B040000 | | 100 ohm, 1/8 W, 1% |
| R404 | 321-0070-00 | B010100 | B039999 | 52.3 ohm, 1/8 W, 1% |
| R404 | 321-0097-00 | B040000 | | 100 ohm, 1/8 W, 1% |
| R405 | 321-0187-00 | B010100 | B039999X | 866 ohm, 1/8 W, 1% |
| R406 | 315-0242-00 | XB040000 | | 2.4K ohm, 1/4 W, 5% |
| R407 | 321-0175-00 | B010100 | B039999X | 649 ohm, 1/8 W, 1% |
| R408 | 321-0121-00 | XB040000 | | 178 ohm, 1/8 W, 1% |
| R409 | 321-0178-00 | B010100 | B039999 | 698 ohm, 1/8 W, 1% |
| R409 | 321-0189-00 | B040000 | | 909 ohm, 1/8 W, 1% |
| R411 | 321-0068-00 | | | 49.9 ohm, 1/8 W, 1% |
| R412 | 315-0221-00 | XB040000 | | 220 ohm, 1/4 W, 5% |
| R413 | 321-0097-00 | XB040000 | | 100 ohm, 1/8 W, 1% |
| R414 | 321-0070-00 | B010100 | B039999 | 52.3 ohm, 1/8 W, 1% |
| R414 | 321-0097-00 | B040000 | | 100 ohm, 1/8 W, 1% |
| R415 | 315-0100-00 | B010100 | B039999X | 10 ohm, 1/4 W, 5% |
| R416 | 315-0242-00 | XB040000 | | 2.4K ohm, 1/4 W, 5% |
| R417 | 321-0175-00 | B010100 | B039999X | 649 ohm, 1/8 W, 1% |
| R418 | 311-1237-00 | XB040000 | | 1K ohm, Var |
| R419 | 323-0071-00 | B010100 | B039999 | 53.6 ohm, 1/2 W, 1% |
| R419 | 321-0189-00 | B040000 | | 909 ohm, 1/8 W, 1% |
| R421 | 315-0620-00 | B010100 | B039999 | 62 ohm, 1/4 W, 5% |
| R421 | 321-0089-00 | B040000 | | 82.5 ohm, 1/8 W, 1% |
| R422 | 311-1278-00 | XB040000 | | 250 ohm, Var |
| RT422 | 307-0181-00 | B010100 | B039999X | 100K ohm, Thermal |
| R423 | 315-0471-00 | B010100 | B010894 | 470 ohm, 1/4 W, 5% |
| R423 | 315-0391-00 | B010895 | B011199 | 390 ohm, (nominal value), selected |
| R423 | 311-0609-00 | B011200 | B039999 | 2K ohm, Var |
| R423 | 315-0101-00 | B040000 | | 100 ohm, 1/4 W, 5% |

| Ckt. No. | Tektronix Part No. | Serial/Model No. Eff | Disc | Description |
|------------------|--------------------|----------------------|----------|----------------------|
| RESISTORS (cont) | | | | |
| R424 | 311-1239-00 | B010100 | B039999 | 2.5K ohm, Var |
| R424 | 315-0101-00 | B040000 | | 100 ohm, 1/4 W, 5% |
| R425 | 311-1238-00 | XB040000 | | 5K ohm, Var |
| R426 | 321-0423-00 | B010100 | B039999 | 249K ohm, 1/8 W, 1% |
| R426 | 311-1228-00 | B040000 | | 10K ohm, Var |
| R427 | 323-0158-00 | B010100 | B010210 | 432 ohm, 1/2 W, 1% |
| R427 | 323-0144-00 | B010211 | B039999 | 309 ohm, 1/2 W, 1% |
| R427 | 311-1225-00 | B040000 | | 1K ohm, Var |
| R428 | 323-0158-00 | B010100 | B010210 | 432 ohm, 1/2 W, 1% |
| R428 | 323-0144-00 | B010211 | B039999X | 309 ohm, 1/2 W, 1% |
| R429 | 311-1236-00 | XB010211 | B039999X | 250 ohm, Var |
| R430 | 323-0159-00 | XB040000 | | 442 ohm, 1/2 W, 1% |
| R431 | 317-0220-00 | XB040000 | | 22 ohm, 1/8 W, 1% |
| R432 | 315-0131-00 | XB040000 | | 130 ohm, 1/4 W, 5% |
| R433 | 311-1138-00 | B010100 | B039999 | 1K ohm, Var |
| R433 | 323-0118-00 | B040000 | | 165 ohm, 1/2 W, 1% |
| R434 | 311-1138-00 | B010100 | B039999 | 1K ohm, Var |
| R434 | 315-0100-00 | B040000 | | 10 ohm, 1/4 W, 5% |
| R435 | 321-0059-00 | XB040000 | | 40.2 ohm, 1/8 W, 1% |
| R436 | 317-0100-00 | XB040000 | | 10 ohm, 1/8 W, 1% |
| R437 | 323-0158-00 | B010100 | B039999 | 432 ohm, 1/2 W, 1% |
| R437 | 317-0561-00 | B040000 | | 560 ohm, 1/8 W, 1% |
| R438 | 323-0158-00 | B010100 | B039999 | 432 ohm, 1/2 W, 1% |
| R438 | 311-1260-00 | B040000 | | 250 ohm, Var |
| R440 | 321-0080-00 | B010100 | B039999 | 66.5 ohm, 1/8 W, 1% |
| R440 | 323-0159-00 | B040000 | | 442 ohm, 1/2 W, 1% |
| R441 | 321-0064-00 | B010100 | B039999 | 45.3 ohm, 1/8 W, 1% |
| R441 | 317-0220-00 | B040000 | | 22 ohm, 1/8 W, 1% |
| R442 | 311-1139-00 | B010100 | B039999 | 500 ohm, Var |
| R442 | 315-0131-00 | B040000 | | 130 ohm, 1/4 W, 5% |
| R443 | 321-0193-00 | B010100 | B039999 | 1K ohm, 1/8 W, 1% |
| R443 | 323-0118-00 | B040000 | | 165 ohm, 1/2 W, 1% |
| R444 | 315-0302-00 | B010100 | B039999 | 3K ohm, 1/4 W, 5% |
| R444 | 315-0100-00 | B040000 | | 10 ohm, 1/4 W, 5% |
| R445 | 315-0472-00 | B010100 | B039999 | 4.7K ohm, 1/4 W, 5% |
| R445 | 321-0059-00 | B040000 | | 40.2 ohm, 1/8 W, 1% |
| R446 | 321-0070-00 | B010100 | B039999X | 52.3 ohm, 1/8 W, 1% |
| R447 | 321-0070-00 | B010100 | B039999X | 52.3 ohm, 1/8 W, 1% |
| R448 | 322-0662-00 | B010100 | B039999 | 334 ohm, 1/4 W, 1/2% |
| R448 | 315-0622-00 | B040000 | | 6.2K ohm, 1/4 W, 5% |
| RT448 | 307-0181-00 | XB040000 | | 100K ohm, Thermal |
| R449 | 322-0180-00 | B010100 | B039999 | 732 ohm, 1/4 W, 5% |
| R449 | 317-0102-00 | B040000 | | 1K ohm, 1/8 W, 5% |
| R451 | 321-0196-00 | B010100 | B039999 | 1.07K ohm, 1/8 W, 1% |
| R451 | 315-0820-00 | B040000 | | 82 ohm, 1/4 W, 5% |

| Ckt. No. | Tektronix Part No. | Serial/Model No. Eff | Disc | Description |
|------------------|--------------------|----------------------|----------|-----------------------|
| RESISTORS (cont) | | | | |
| R452 | 315-0101-00 | B010100 | B039999 | 100 ohm, 1/4 W, 5% |
| R452 | 315-0301-00 | B040000 | | 300 ohm, 1/4 W, 5% |
| R453 | 321-0223-00 | B010100 | B039999 | 2.05K ohm, 1/8 W, 1% |
| R453 | 323-0157-00 | B040000 | | 422 ohm, 1/2 W, 1% |
| R454 | 321-0164-00 | B010100 | B039999X | 499 ohm, 1/8 W, 1% |
| R455 | 311-1138-00 | B010100 | B039999X | 1K ohm, Var |
| R457 | 315-0201-00 | B010100 | B039999X | 200 ohm, 1/4 W, 5% |
| R461 | 317-0101-00 | B010100 | B039999X | 100 ohm, 1/8 W, 5% |
| R462 | 321-0205-00 | XB040000 | | 1.33K ohm, 1/8 W, 1% |
| R463 | 321-0219-00 | XB040000 | | 1.87K ohm, 1/8 W, 1% |
| R464 | 310-0700-00 | B010100 | B039999 | 430K ohm, 4 W, WW, 1% |
| R464 | 321-0093-00 | B040000 | | 90.9 ohm, 1/8 W, 1% |
| R465 | 321-0126-00 | XB040000 | | 200 ohm, 1/8 W, 1% |
| R466 | 311-1226-00 | XB040000 | | 2.5K ohm, Var |
| R468 | 321-0031-00 | XB040000 | | 20.5 ohm, 1/8 W, 1% |
| R469 | 323-0072-00 | XB040000 | | 54.9 ohm, 1/2 W, 1% |
| R471 | 317-0101-00 | B010100 | B039999X | 100 ohm, 1/8 W, 5% |
| R474 | 310-0700-00 | B010100 | B039999 | 430K ohm, 4 W, WW, 1% |
| R474 | 321-0093-00 | B040000 | | 90.9 ohm, 1/8 W, 1% |
| R475 | 321-0126-00 | XB040000 | | 200 ohm, 1/8 W, 1% |
| R478 | 321-0031-00 | XB040000 | | 20.5 ohm, 1/8 W, 1% |
| R480 | 315-0100-00 | XB040000 | | 10 ohm, 1/4 W, 5% |
| R481 | 315-0820-00 | XB040000 | | 82 ohm, 1/4 W, 5% |
| R482 | 315-0820-00 | XB040000 | | 82 ohm, 1/4 W, 5% |
| R483 | 310-0700-00 | XB040000 | | 430 ohm, 4 W, WW, 1% |
| R485 | 301-0100-00 | XB040000 | | 10 ohm, 1/2 W, 5% |
| R491 | 315-0820-00 | XB040000 | | 82 ohm, 1/4 W, 5% |
| R492 | 315-0820-00 | XB040000 | | 82 ohm, 1/4 W, 5% |
| R493 | 310-0700-00 | XB040000 | | 430 ohm, 4 W, WW, 1% |
| R498 | 315-0100-00 | XB040000 | | 10 ohm, 1/4 W, 5% |
| R499 | 315-0100-00 | XB040000 | | 10 ohm, 1/4 W, 5% |
| R502 | 315-0754-00 | | | 750K ohm, 1/4 W, 5% |
| R503 | 315-0334-00 | | | 330K ohm, 1/4 W, 5% |
| R507 | 321-0068-00 | | | 49.9 ohm, 1/8 W, 1% |
| R508 | 321-0068-00 | | | 49.9 ohm, 1/8 W, 1% |
| R509 | 321-0068-00 | | | 49.9 ohm, 1/8 W, 1% |
| R511 | 316-0104-00 | | | 100K ohm, 1/4 W, 10% |
| R512 | 316-0563-00 | | | 56K ohm, 1/4 W, 10% |
| R516 | 316-0105-00 | | | 1M ohm, 1/4 W, 10% |
| R517 | 316-0101-00 | | | 100 ohm, 1/4 W, 10% |
| R518 | 316-0101-00 | | | 100 ohm, 1/4 W, 10% |
| R522 | 316-0101-00 | | | 100 ohm, 1/4 W, 10% |
| R523 | 316-0150-00 | | | 15 ohm, 1/4 W, 10% |
| R524 | 316-0150-00 | | | 15 ohm, 1/4 W, 10% |
| R525 | 316-0101-00 | | | 100 ohm, 1/4 W, 10% |

| Ckt. No. | Tektronix Part No. | Serial/Model No. Eff | Disc | Description |
|-------------------|--------------------|----------------------|---------|----------------------|
| RESISTORS (cont) | | | | |
| R527 | 321-0209-00 | | | 1.47K ohm, 1/8 W, 1% |
| R528 | 315-0390-00 | | | 39 ohm, 1/4 W, 5% |
| R529 | 321-0209-00 | | | 1.47K ohm, 1/8 W, 1% |
| R530 ¹ | 311-1192-00 | | | 10K ohm, Var |
| R531 | 316-0681-00 | | | 680 ohm, 1/4 W, 10% |
| R535 | 311-1230-00 | | | 20K ohm, Var |
| R536 | 315-0202-00 | | | 2K ohm, 1/4 W, 5% |
| R537 | 315-0560-00 | | | 56 ohm, 1/4 W, 5% |
| R538 | 315-0362-00 | | | 3.6K ohm, 1/4 W, 5% |
| R539 | 316-0222-00 | | | 2.2K ohm, 1/4 W, 10% |
| R540 | 316-0222-00 | | | 2.2K ohm, 1/4 W, 10% |
| R541 | 316-0682-00 | | | 6.8K ohm, 1/4 W, 10% |
| R542 | 316-0182-00 | | | 1.8K ohm, 1/4 W, 10% |
| R544 | 316-0103-00 | | | 10K ohm, 1/4 W, 10% |
| R545 | 311-1230-00 | | | 20K ohm, Var |
| R546 | 315-0101-00 | | | 100 ohm, 1/4 W, 5% |
| R547 | 315-0101-00 | | | 100 ohm, 1/4 W, 5% |
| R549 | 315-0331-00 | | | 330 ohm, 1/4 W, 5% |
| R550 | 316-0330-00 | | | 33 ohm, 1/4 W, 10% |
| R551 | 323-0305-00 | | | 14.7K ohm, 1/2 W, 1% |
| R552 | 316-0330-00 | | | 33 ohm, 1/4 W, 10% |
| R553 | 316-0153-00 | | | 15K ohm, 1/4 W, 10% |
| R554 | 316-0104-00 | | | 100K ohm, 1/4 W, 10% |
| R555 | 311-1230-00 | | | 20K ohm, Var |
| R556 | 316-0562-00 | | | 5.6K ohm, 1/4 W, 10% |
| R557 | 317-0101-00 | B010100 | B010724 | 100 ohm, 1/8 W, 5% |
| R557 | 321-0097-00 | B010725 | | 100 ohm, 1/8 W, 1% |
| RT557 | 307-0124-00 | XB010725 | | 5K ohm, Thermal |
| R558 | 321-0258-00 | | | 4.75K ohm, 1/8 W, 1% |
| R602 | 316-0470-00 | | | 47 ohm, 1/4 W, 10% |
| R603 | 325-0073-00 | | | 3.57M ohm, 1/2 W, 1% |
| R604 | 321-0385-00 | | | 100K ohm, 1/8 W, 1% |
| R606 | 323-0480-00 | | | 976K ohm, 1/2 W, 1% |
| R607 | 321-0451-00 | | | 487K ohm, 1/8 W, 1% |
| R609 | 316-0102-00 | B010100 | B010399 | 1K ohm, 1/4 W, 10% |
| R609 | 316-0274-00 | B010400 | | 270K ohm, 1/4 W, 10% |
| R611 | 316-0104-00 | | | 100K ohm, 1/4 W, 10% |
| R612 | 316-0563-00 | | | 56K ohm, 1/4 W, 10% |
| R616 | 321-0481-00 | | | 1M ohm, 1/8 W, 1% |
| R617 | 316-0101-00 | | | 100 ohm, 1/4 W, 10% |
| R618 | 316-0101-00 | | | 100 ohm, 1/4 W, 10% |
| R622 | 316-0101-00 | | | 100 ohm, 1/4 W, 10% |
| R623 | 316-0150-00 | | | 15 ohm, 1/4 W, 10% |
| R624 | 316-0150-00 | | | 15 ohm, 1/4 W, 10% |
| R625 | 316-0101-00 | | | 100 ohm, 1/4 W, 10% |

¹Furnished as a unit with S530.

| Ckt. No. | Tektronix Part No. | Serial/Model No. Eff | Disc | Description |
|-------------------|--------------------|----------------------|----------|----------------------|
| RESISTORS (cont) | | | | |
| R627 | 321-0209-00 | | | 1.47K ohm, 1/8 W, 1% |
| R628 | 315-0390-00 | | | 39 ohm, 1/4 W, 5% |
| R629 | 321-0209-00 | | | 1.47K ohm, 1/8 W, 1% |
| R630 ¹ | 311-1192-00 | | | 10K ohm, Var |
| R631 | 316-0681-00 | | | 680 ohm, 1/4 W, 10% |
| R635 | 311-1230-00 | | | 20K ohm, Var |
| R636 | 315-0202-00 | | | 2K ohm, 1/4 W, 5% |
| R637 | 315-0560-00 | | | 56 ohm, 1/4 W, 5% |
| R638 | 315-0362-00 | | | 3.6K ohm, 1/4 W, 5% |
| R639 | 316-0222-00 | | | 2.2K ohm, 1/4 W, 10% |
| R640 | 316-0222-00 | | | 2.2K ohm, 1/4 W, 10% |
| R641 | 316-0682-00 | | | 6.8K ohm, 1/4 W, 10% |
| R642 | 316-0182-00 | | | 1.8K ohm, 1/4 W, 10% |
| R644 | 316-0103-00 | | | 10K ohm, 1/4 W, 10% |
| R645 | 311-1230-00 | | | 20K ohm, Var |
| R646 | 315-0101-00 | | | 100 ohm, 1/4 W, 5% |
| R647 | 315-0101-00 | | | 100 ohm, 1/4 W, 5% |
| R649 | 315-0331-00 | | | 330 ohm, 1/4 W, 5% |
| R650 | 316-0330-00 | | | 33 ohm, 1/4 W, 10% |
| R651 | 323-0305-00 | | | 14.7K ohm, 1/2 W, 1% |
| R652 | 316-0330-00 | | | 33 ohm, 1/4 W, 10% |
| R655 | 311-1230-00 | | | 20K ohm, Var |
| R656 | 316-0562-00 | | | 5.6K ohm, 1/4 W, 10% |
| R657 | 317-0101-00 | B010100 | B010724 | 100 ohm, 1/8 W, 5% |
| R657 | 321-0097-00 | B010725 | | 100 ohm, 1/8 W, 1% |
| RT657 | 307-0124-00 | XB010725 | | 5K ohm, Thermal |
| R658 | 321-0258-00 | | | 4.75K ohm, 1/8 W, 1% |
| R671 | 316-0100-00 | | | 10 ohm, 1/4 W, 10% |
| R672 | 315-0680-00 | | | 68 ohm, 1/4 W, 5% |
| R674 | 316-0100-00 | B010100 | B010804X | 10 ohm, 1/4 W, 10% |
| R674 | 315-0470-00 | XB011200 | | 47 ohm, 1/4 W, 5% |
| R675 | 311-1259-00 | | | 100 ohm, Var |
| R676 | 315-0430-00 | | | 43 ohm, 1/4 W, 5% |
| R677 | 315-0102-00 | | | 1K ohm, 1/4 W, 5% |
| R678 | 315-0510-00 | | | 51 ohm, 1/4 W, 5% |
| R679 | 315-0120-00 | | | 12 ohm, 1/4 W, 5% |
| R681 | 316-0100-00 | | | 10 ohm, 1/4 W, 10% |
| R682 | 315-0680-00 | | | 68 ohm, 1/4 W, 5% |
| R683 | 315-0471-00 | | | 470 ohm, 1/4 W, 5% |
| R684 | 316-0101-00 | B010100 | B010804X | 100 ohm, 1/4 W, 10% |
| R687 | 315-0102-00 | | | 1K ohm, 1/4 W, 5% |
| R688 | 315-0510-00 | | | 51 ohm, 1/4 W, 5% |
| R689 | 315-0120-00 | | | 12 ohm, 1/4 W, 5% |
| R690 | 316-0100-00 | | | 10 ohm, 1/4 W, 10% |
| R691 | 316-0104-00 | | | 100K ohm, 1/4 W, 10% |

¹Furnished as a unit with the S630.

| Ckt. No. | Tektronix Part No. | Serial/Model No. Eff | Disc | Description |
|------------------|--------------------|----------------------|---------|----------------------|
| RESISTORS (cont) | | | | |
| R692 | 315-0152-00 | | | 1.5K ohm, 1/4 W, 5% |
| R694 | 315-0431-00 | | | 430 ohm, 1/4 W, 5% |
| R697 | 316-0100-00 | | | 10 ohm, 1/4 W, 10% |
| R699 | 316-0100-00 | | | 10 ohm, 1/4 W, 10% |
| R803 | 315-0391-00 | | | 390 ohm, 1/4 W, 5% |
| R804 | 321-0186-00 | | | 845 ohm, 1/8 W, 1% |
| R805 | 316-0220-00 | | | 22 ohm, 1/4 W, 10% |
| R807 | 321-0243-00 | | | 3.32K ohm, 1/8 W, 1% |
| R808 | 321-0206-00 | | | 1.37K ohm, 1/8 W, 1% |
| R809 | 315-0132-00 | | | 1.3K ohm, 1/4 W, 5% |
| R811 | 315-0390-00 | | | 39 ohm, 1/4 W, 5% |
| R812 | 321-0211-00 | | | 1.54K ohm, 1/8 W, 1% |
| R814 | 315-0332-00 | | | 3.3K ohm, 1/4 W, 5% |
| R815 | 315-0151-00 | | | 150 ohm, 1/4 W, 5% |
| R817 | 315-0681-00 | | | 680 ohm, 1/4 W, 5% |
| R818 | 315-0681-00 | | | 680 ohm, 1/4 W, 5% |
| R822 | 315-0102-00 | B010100 | B010599 | 1K ohm, 1/4 W, 5% |
| R822 | 315-0103-00 | B010600 | | 10K ohm, 1/4 W, 5% |
| R823 | 315-0153-00 | | | 15K ohm, 1/4 W, 5% |
| R824 | 315-0103-00 | | | 10K ohm, 1/4 W, 5% |
| R827 | 315-0102-00 | | | 1K ohm, 1/4 W, 5% |
| R828 | 315-0102-00 | | | 1K ohm, 1/4 W, 5% |
| R829 | 316-0220-00 | | | 22 ohm, 1/4 W, 10% |
| R831 | 315-0102-00 | | | 1K ohm, 1/4 W, 5% |
| R834 | 315-0100-00 | | | 10 ohm, 1/4 W, 5% |
| R836 | 315-0100-00 | | | 10 ohm, 1/4 W, 5% |
| R838 | 316-0101-00 | | | 100 ohm, 1/4 W, 10% |
| R853 | 315-0471-00 | | | 470 ohm, 1/4 W, 5% |
| R854 | 321-0200-00 | | | 1.18K ohm, 1/8 W, 1% |
| R855 | 316-0220-00 | | | 22 ohm, 1/4 W, 10% |
| R856 | 316-0270-00 | | | 27 ohm, 1/4 W, 10% |
| R857 | 321-0243-00 | | | 3.32K ohm, 1/8 W, 1% |
| R858 | 321-0201-00 | | | 1.21K ohm, 1/8 W, 1% |
| R859 | 315-0132-00 | | | 1.3K ohm, 1/4 W, 5% |
| R861 | 315-0390-00 | | | 39 ohm, 1/4 W, 5% |
| R862 | 321-0211-00 | B010100 | B010599 | 1.54K ohm, 1/8 W, 1% |
| R862 | 321-0209-00 | B010600 | | 1.47K ohm, 1/8 W, 1% |
| R863 | 315-0103-00 | XB010600 | | 10K ohm, 1/4 W, 5% |
| R864 | 315-0332-00 | | | 3.3K ohm, 1/4 W, 5% |
| R865 | 315-0151-00 | | | 150 ohm, 1/4 W, 5% |
| R866 | 315-0471-00 | | | 470 ohm, 1/4 W, 5% |
| R871 | 315-0472-00 | | | 4.7K ohm, 1/4 W, 5% |
| R872 | 315-0241-00 | | | 240 ohm, 1/4 W, 5% |
| R877 | 315-0102-00 | | | 1K ohm, 1/4 W, 5% |
| R879 | 315-0274-00 | | | 270K ohm, 1/4 W, 5% |

| Ckt. No. | Tektronix Part No. | Serial/Model No. Eff | Disc | Description |
|------------------|--------------------|----------------------|---------|------------------------|
| RESISTORS (cont) | | | | |
| R1001 | 315-0360-00 | | | 36 ohm, 1/4 W, 5% |
| R1002 | 303-0432-00 | | | 4.3K ohm, 1 W, 5% |
| R1003 | 316-0101-00 | | | 100 ohm, 1/4 W, 10% |
| R1004 | 315-0360-00 | | | 36 ohm, 1/4 W, 5% |
| R1005 | 316-0220-00 | | | 22 ohm, 1/4 W, 10% |
| R1006 | 308-0421-00 | | | 3K ohm, 3 W, WW, 5% |
| R1011 | 316-0103-00 | | | 10K ohm, 1/4 W, 10% |
| R1012 | 321-0164-00 | | | 499 ohm, 1/8 W, 1% |
| R1013 | 321-0228-00 | | | 2.32K ohm, 1/8 W, 1% |
| R1016 | 321-0195-00 | | | 1.05K ohm, 1/8 W, 1% |
| R1017 | 321-0250-00 | | | 3.92K ohm, 1/8 W, 1% |
| R1021 | 321-0193-00 | | | 1K ohm, 1/8 W, 1% |
| R1022 | 321-0193-00 | | | 1K ohm, 1/8 W, 1% |
| R1024 | 321-0165-00 | | | 511 ohm, 1/8 W, 1% |
| R1026 | 316-0181-00 | | | 180 ohm, 1/4 W, 10% |
| R1029 | 316-0101-00 | | | 100 ohm, 1/4 W, 10% |
| R1031 | 316-0470-00 | | | 47 ohm, 1/4 W, 10% |
| R1032 | 316-0101-00 | | | 100 ohm, 1/4 W, 10% |
| R1033 | 321-0256-00 | | | 4.53K ohm, 1/8 W, 1% |
| R1035 | 316-0101-00 | | | 100 ohm, 1/4 W, 10% |
| R1037 | 321-0251-01 | | | 4.02K ohm, 1/8 W, 1/2% |
| R1038 | 316-0470-00 | | | 47 ohm, 1/4 W, 10% |
| R1039 | 321-0228-00 | | | 2.32K ohm, 1/8 W, 1% |
| R1041 | 316-0101-00 | | | 100 ohm, 1/4 W, 10% |
| R1044 | 321-0227-00 | | | 2.26K ohm, 1/8 W, 1% |
| R1045 | 316-0101-00 | | | 100 ohm, 1/4 W, 10% |
| R1046 | 316-0562-00 | B010100 | B010599 | 5.6K ohm, 1/4 W, 10% |
| R1046 | 301-0562-00 | B010600 | | 5.6K ohm, 1/2 W, 5% |
| R1047 | 316-0681-00 | B010100 | B010599 | 680 ohm, 1/4 W, 10% |
| R1047 | 315-0681-00 | B010600 | | 680 ohm, 1/4 W, 5% |
| R1048 | 315-0752-00 | | | 7.5K ohm, 1/4 W, 5% |
| R1049 | 316-0681-00 | B010100 | B010599 | 680 ohm, 1/4 W, 10% |
| R1049 | 315-0681-00 | B010600 | | 680 ohm, 1/4 W, 5% |
| R1052 | 315-0561-00 | | | 560 ohm, 1/4 W, 5% |
| R1053 | 315-0622-00 | B010100 | B010599 | 6.2K ohm, 1/4 W, 5% |
| R1053 | 301-0622-00 | B010600 | | 6.2K ohm, 1/2 W, 5% |
| R1054 | 316-0102-00 | B010100 | B010599 | 1K ohm, 1/4 W, 10% |
| R1054 | 315-0102-00 | B010600 | | 1K ohm, 1/4 W, 5% |
| R1057 | 316-0562-00 | B010100 | B010599 | 5.6K ohm, 1/4 W, 10% |
| R1057 | 315-0562-00 | B010600 | | 5.6K ohm, 1/4 W, 5% |
| R1061 | 315-0360-00 | | | 36 ohm, 1/4 W, 5% |
| R1062 | 301-0432-00 | | | 4.3K ohm, 1/2 W, 5% |
| R1063 | 316-0101-00 | | | 100 ohm, 1/4 W, 10% |
| R1064 | 315-0360-00 | | | 36 ohm, 1/4 W, 5% |
| R1065 | 316-0220-00 | | | 22 ohm, 1/4 W, 10% |

| Ckt. No. | Tektronix Part No. | Serial/Model No. Eff | Disc | Description |
|--------------------|--------------------|----------------------|------|------------------------|
| RESISTORS (cont) | | | | |
| R1066 | 308-0421-00 | | | 3K ohm, 3 W, WW, 5% |
| R1071 | 316-0103-00 | | | 10K ohm, 1/4 W, 10% |
| R1072 | 321-0164-00 | | | 499 ohm, 1/8 W, 1% |
| R1073 | 321-0228-00 | | | 2.32K ohm, 1/8 W, 1% |
| R1076 | 321-0195-00 | | | 1.05K ohm, 1/8 W, 1% |
| R1077 | 321-0250-00 | | | 3.92K ohm, 1/8 W, 1% |
| R1081 | 321-0193-00 | | | 1K ohm, 1/8 W, 1% |
| R1082 | 321-0193-00 | | | 1K ohm, 1/8 W, 1% |
| R1084 | 321-0165-00 | | | 511 ohm, 1/8 W, 1% |
| R1086 | 316-0181-00 | | | 180 ohm, 1/4 W, 10% |
| R1089 | 316-0101-00 | | | 100 ohm, 1/4 W, 10% |
| R1091 | 316-0470-00 | | | 47 ohm, 1/4 W, 10% |
| R1092 | 316-0101-00 | | | 100 ohm, 1/4 W, 10% |
| R1093 | 321-0256-00 | | | 4.53K ohm, 1/8 W, 1% |
| R1095 | 316-0101-00 | | | 100 ohm, 1/4 W, 10% |
| R1097 | 321-0251-01 | | | 4.02K ohm, 1/8 W, 1/2% |
| R1098 | 321-0229-00 | | | 2.37K ohm, 1/8 W, 1% |
| R1101 | 316-0682-00 | | | 6.8K ohm, 1/4 W, 10% |
| R1110 | 311-1464-00 | | | 2K ohm, Var |
| R1111 | 321-0169-00 | | | 562 ohm, 1/8 W, 1% |
| R1112 | 321-0068-00 | | | 49.9 ohm, 1/8 W, 1% |
| R1113 | 321-0125-00 | | | 196 ohm, 1/8 W, 1% |
| R1115 | 311-1244-00 | | | 100 ohm, Var |
| R1117 | 321-0231-00 | | | 2.49K ohm, 1/8 W, 1% |
| R1131 | 323-0498-04 | | | 1.5M ohm, 1/2 W, 1/10% |
| R1133 | 323-0481-04 | | | 1M ohm, 1/2 W, 1/10% |
| R1134 | 321-0648-04 | | | 500K ohm, 1/8 W, 1/10% |
| R1135 | 321-0618-04 | | | 250K ohm, 1/8 W, 1/10% |
| R1136 | 321-0414-04 | | | 200K ohm, 1/8 W, 1/10% |
| R1137 | 321-0385-04 | | | 100K ohm, 1/8 W, 1/10% |
| R1138 | 321-0756-04 | | | 50K ohm, 1/8 W, 1/10% |
| R1140 ¹ | 311-1374-00 | | | 50K ohm, Var |
| R1141 | 316-0154-00 | | | 150K ohm, 1/4 W, 10% |
| R1145 | 311-1245-00 | | | 10K ohm, Var |
| R1146 | 316-0472-00 | | | 4.7K ohm, 1/4 W, 10% |
| R1151 | 321-0429-00 | | | 287K ohm, 1/8 W, 1% |
| R1153 | 321-0338-00 | | | 32.4K ohm, 1/8 W, 1% |
| R1155 | 311-1410-00 | | | 25K ohm, Var |
| R1161 | 323-0498-04 | | | 1.5M ohm, 1/2 W, 1/10% |
| R1163 | 323-0481-04 | | | 1M ohm, 1/2 W, 1/10% |
| R1164 | 321-0648-04 | | | 500K ohm, 1/8 W, 1/10% |
| R1165 | 321-0618-04 | | | 250K ohm, 1/8 W, 1/10% |
| R1166 | 321-0414-04 | | | 200K ohm, 1/8 W, 1/10% |
| R1167 | 321-0385-04 | | | 100K ohm, 1/8 W, 1/10% |
| R1168 | 321-0756-04 | | | 50K ohm, 1/8 W, 1/10% |

¹Furnished as a unit with S1140.

| Ckt. No. | Tektronix Part No. | Serial/Model No. Eff | Disc | Description |
|------------------|--------------------|----------------------|------|-----------------------|
| RESISTORS (cont) | | | | |
| | R1170 | 316-0473-00 | | 47K ohm, 1/4 W, 10% |
| | R1175 | 311-1245-00 | | 10K ohm, Var |
| | R1201 | 316-0471-00 | | 470 ohm, 1/4 W, 10% |
| | R1202 | 321-0212-00 | | 1.58K ohm, 1/8 W, 1% |
| | R1205A,B | 311-1430-00 | | 5K ohm x 50K ohm, Var |
| | R1206 | 315-0202-00 | | 2K ohm, 1/4 W, 5% |
| | R1207 | 315-0203-00 | | 20K ohm, 1/4 W, 5% |
| | R1208 | 315-0432-00 | | 4.3K ohm, 1/4 W, 5% |
| | R1209 | 315-0433-00 | | 43K ohm, 1/4 W, 5% |
| | R1211 | 321-0130-00 | | 221 ohm, 1/8 W, 1% |
| | R1212 | 316-0102-00 | | 1K ohm, 1/4 W, 10% |
| | R1214 | 321-0174-00 | | 634 ohm, 1/8 W, 1% |
| | R1215 | 311-1222-00 | | 100 ohm, Var |
| | R1216 | 321-0264-00 | | 5.49K ohm, 1/8 W, 1% |
| | R1217 | 321-0147-00 | | 332 ohm, 1/8 W, 1% |
| | R1219 | 321-0164-00 | | 499 ohm, 1/8 W, 1% |
| | R1220 | 321-0034-00 | | 22.1 ohm, 1/8 W, 1% |
| | R1221 | 321-0173-00 | | 619 ohm, 1/8 W, 1% |
| | R1222 | 321-0173-00 | | 619 ohm, 1/8 W, 1% |
| | R1223 | 321-0184-00 | | 806 ohm, 1/8 W, 1% |
| | R1224 | 323-0248-00 | | 3.74K ohm, 1/2 W, 1% |
| | R1225 | 311-1226-00 | | 2.5K ohm, Var |
| | R1226 | 323-0296-00 | | 11.8K ohm, 1/2 W, 1% |
| | R1228 | 321-0210-00 | | 1.5K ohm, 1/8 W, 1% |
| | R1229 | 316-0154-00 | | 150K ohm, 1/4 W, 10% |
| | RT1230 | 307-0122-00 | | 50 ohm, Thermal |
| | R1231 | 321-0222-00 | | 2K ohm, 1/8 W, 1% |
| | R1232 | 315-0270-00 | | 27 ohm, 1/4 W, 5% |
| | R1233 | 321-0184-00 | | 806 ohm, 1/8 W, 1% |
| | R1234 | 323-0248-00 | | 3.74K ohm, 1/2 W, 1% |
| | R1235 | 323-0191-00 | | 953 ohm, 1/2 W, 1% |
| | R1236 | 323-0296-00 | | 11.8K ohm, 1/2 W, 1% |
| | R1237 | 311-1225-00 | | 1K ohm, Var |
| | R1238 | 311-1222-00 | | 100 ohm, Var |
| | R1239 | 321-0110-00 | | 137 ohm, 1/8 W, 1% |
| | R1241 | 321-0168-00 | | 549 ohm, 1/8 W, 1% |
| | R1242 | 321-0168-00 | | 549 ohm, 1/8 W, 1% |
| | R1244 | 321-0122-00 | | 182 ohm, 1/8 W, 1% |
| | R1246 | 321-0260-00 | | 4.99K ohm, 1/8 W, 1% |
| | R1247 | 315-0201-00 | | 200 ohm, 1/4 W, 5% |
| | R1248 | 321-0228-00 | | 2.32K ohm, 1/8 W, 1% |
| | R1249 | 315-0182-00 | | 1.8K ohm, 1/4 W, 5% |
| | R1253 | 321-0299-00 | | 12.7K ohm, 1/8 W, 1% |
| | R1254 | 321-0140-00 | | 280 ohm, 1/8 W, 1% |
| | R1255 | 302-0181-00 | | 180 ohm, 1/2 W, 10% |

| Ckt. No. | Tektronix Part No. | Serial/Model No. Eff | Disc | Description |
|------------------|--------------------|----------------------|---------|----------------------|
| RESISTORS (cont) | | | | |
| R1260 | 322-0289-00 | | | 10K ohm, 1/4 W, 1% |
| R1261 | 322-0289-00 | | | 10K ohm, 1/4 W, 1% |
| R1262 | 321-0189-00 | | | 909 ohm, 1/8 W, 1% |
| R1263 | 316-0470-00 | | | 47 ohm, 1/4 W, 10% |
| R1264 | 302-0393-00 | | | 39K ohm, 1/2 W, 10% |
| R1266 | 316-0101-00 | | | 100 ohm, 1/4 W, 10% |
| R1268 | 321-0222-00 | | | 2K ohm, 1/8 W, 1% |
| R1269 | 321-0268-00 | | | 6.04K ohm, 1/8 W, 1% |
| R1273 | 321-0299-00 | | | 12.7K ohm, 1/8 W, 1% |
| R1274 | 323-0177-00 | | | 681 ohm, 1/2 W, 1% |
| R1275 | 302-0221-00 | | | 220 ohm, 1/2 W, 10% |
| R1280 | 322-0289-00 | | | 10K ohm, 1/4 W, 1% |
| R1281 | 322-0289-00 | | | 10K ohm, 1/4 W, 1% |
| R1282 | 321-0189-00 | | | 909 ohm, 1/8 W, 1% |
| R1283 | 316-0470-00 | | | 47 ohm, 1/4 W, 10% |
| R1284 | 302-0393-00 | | | 39K ohm, 1/2 W, 10% |
| R1286 | 316-0101-00 | | | 100 ohm, 1/4 W, 10% |
| R1288 | 316-0470-00 | | | 47 ohm, 1/4 W, 10% |
| R1289 | 302-0273-00 | | | 27K ohm, 1/2 W, 10% |
| R1301 | 321-0160-00 | | | 453 ohm, 1/8 W, 1% |
| R1302 | 321-0160-00 | | | 453 ohm, 1/8 W, 1% |
| R1303 | 321-0209-00 | | | 1.47K ohm, 1/8 W, 1% |
| R1304 | 315-0472-00 | | | 4.7K ohm, 1/4 W, 5% |
| R1306 | 315-0112-00 | | | 1.1K ohm, 1/4 W, 5% |
| R1307 | 321-0192-00 | | | 976 ohm, 1/8 W, 1% |
| R1308 | 321-0171-00 | | | 590 ohm, 1/8 W, 1% |
| R1314 | 315-0182-00 | B010100 | B010151 | 1.8K ohm, 1/4 W, 5% |
| R1314 | 315-0911-00 | B010152 | | 910 ohm, 1/4 W, 5% |
| R1317 | 301-0221-00 | B010100 | B010151 | 220 ohm, 1/2 W, 5% |
| R1317 | 301-0471-00 | B010152 | | 470 ohm, 1/2 W, 5% |
| R1321 | 321-0160-00 | | | 453 ohm, 1/8 W, 1% |
| R1322 | 321-0160-00 | | | 453 ohm, 1/8 W, 1% |
| R1323 | 321-0209-00 | | | 1.47K ohm, 1/8 W, 1% |
| R1324 | 315-0472-00 | | | 4.7K ohm, 1/4 W, 5% |
| R1326 | 315-0112-00 | | | 1.1K ohm, 1/4 W, 5% |
| R1327 | 321-0192-00 | | | 976 ohm, 1/8 W, 1% |
| R1328 | 321-0171-00 | | | 590 ohm, 1/8 W, 1% |
| R1334 | 315-0182-00 | B010100 | B010151 | 1.8K ohm, 1/4 W, 5% |
| R1334 | 315-0911-00 | B010152 | | 910 ohm, 1/4 W, 5% |
| R1337 | 301-0221-00 | B010100 | B010151 | 220 ohm, 1/2 W, 5% |
| R1337 | 301-0471-00 | B010152 | | 470 ohm, 1/2 W, 5% |
| R1339 | 316-0220-00 | | | 22 ohm, 1/4 W, 10% |
| R1345 | 315-0202-00 | | | 2K ohm, 1/4 W, 5% |
| R1348 | 316-0220-00 | | | 22 ohm, 1/4 W, 10% |
| R1349 | 316-0220-00 | | | 22 ohm, 1/4 W, 10% |

| Ckt. No. | Tektronix Part No. | Serial/Model No. Eff | Disc | Description |
|------------------|--------------------|----------------------|------|----------------------|
| RESISTORS (cont) | | | | |
| R1400 | 311-1228-00 | | | 10K ohm, Var |
| R1401 | 322-0464-00 | | | 665K ohm, 1/4 W, 1% |
| R1402 | 316-0224-00 | | | 220K ohm, 1/4 W, 10% |
| R1403 | 315-0273-00 | | | 27K ohm, 1/4 W, 5% |
| R1404 | 315-0103-00 | | | 10K ohm, 1/4 W, 5% |
| R1406 | 316-0683-00 | | | 68K ohm, 1/4 W, 10% |
| R1407 | 316-0102-00 | | | 1K ohm, 1/4 W, 10% |
| R1408 | 315-0242-00 | | | 2.4K ohm, 1/4 W, 5% |
| R1409 | 316-0104-00 | | | 100K ohm, 1/4 W, 10% |
| R1411 | 321-0327-00 | | | 24.9K ohm, 1/8 W, 1% |
| R1412 | 321-0329-00 | | | 26.1K ohm, 1/8 W, 1% |
| R1413 | 316-0103-00 | | | 10K ohm, 1/4 W, 10% |
| R1414 | 316-0392-00 | | | 3.9K ohm, 1/4 W, 10% |
| R1416 | 316-0472-00 | | | 4.7K ohm, 1/4 W, 10% |
| R1420 | 315-0394-00 | | | 390K ohm, 1/4 W, 5% |
| R1421 | 316-0103-00 | | | 10K ohm, 1/4 W, 10% |
| R1422 | 316-0103-00 | | | 10K ohm, 1/4 W, 10% |
| R1423 | 316-0103-00 | | | 10K ohm, 1/4 W, 10% |
| R1430 | 311-0075-00 | | | 5M ohm, Var |
| R1431A | 307-0290-04 | | | 6.57M ohm, |
| R1431B | | | | 23.6M ohm, |
| R1431C | | | | 550K ohm, Thick film |
| R1431D | | | | 24.5M ohm, |
| R1440 | 311-1313-00 | | | 2K ohm, Var |
| R1441 | 302-0562-00 | | | 5.6K ohm, 1/2 W, 10% |
| R1442 | 311-1235-00 | | | 100K ohm, Var |
| R1445 | 311-1372-00 | | | 100K ohm, Var |
| R1446 | 311-1227-00 | | | 5K ohm, Var |
| R1447 | 315-0223-00 | | | 22K ohm, 1/4 W, 5% |
| R1448 | 315-0243-00 | | | 24K ohm, 1/4 W, 5% |
| R1449 | 316-0101-00 | | | 100 ohm, 1/4 W, 10% |
| R1451 | 301-0243-00 | | | 24K ohm, 1/2 W, 5% |
| R1452 | 316-0221-00 | | | 220 ohm, 1/4 W, 10% |
| R1453 | 316-0470-00 | | | 47 ohm, 1/4 W, 10% |
| R1460 | 311-1373-00 | | | 5K ohm, Var |
| R1461 | 315-0302-00 | | | 3K ohm, 1/4 W, 5% |
| R1462 | 315-0242-00 | | | 2.4K ohm, 1/4 W, 5% |
| R1463 | 315-0122-00 | | | 1.2K ohm, 1/4 W, 5% |
| R1464 | 315-0153-00 | | | 15K ohm, 1/4 W, 5% |
| R1466 | 321-0220-00 | | | 1.91K ohm, 1/8 W, 1% |
| R1467 | 321-0168-00 | | | 549 ohm, 1/8 W, 1% |
| R1468 | 321-0249-00 | | | 3.83K ohm, 1/8 W, 1% |
| R1469 | 323-0322-00 | | | 22.1K ohm, 1/2 W, 1% |
| R1470 | 321-0307-00 | | | 15.4K ohm, 1/8 W, 1% |
| R1471 | 316-0101-00 | | | 100 ohm, 1/4 W, 10% |

Electrical Parts List-465

| Ckt. No. | Tektronix Part No. | Serial/Model No. Eff | Disc | Description |
|------------------|--------------------|----------------------|---------|-----------------------|
| RESISTORS (cont) | | | | |
| R1472 | 316-0391-00 | | | 390 ohm, 1/4 W, 10% |
| R1473 | 316-0102-00 | | | 1K ohm, 1/4 W, 10% |
| R1474 | 316-0101-00 | | | 100 ohm, 1/4 W, 10% |
| R1475 | 316-0102-00 | | | 1K ohm, 1/4 W, 10% |
| R1476 | 315-0911-00 | | | 910 ohm, 1/4 W, 5% |
| R1477 | 321-0201-00 | | | 1.21K ohm, 1/8 W, 1% |
| R1478 | 302-0393-00 | | | 39K ohm, 1/2 W, 10% |
| R1480 | 311-1231-00 | | | 25K ohm, Var |
| R1481 | 316-0103-00 | | | 10K ohm, 1/4 W, 10% |
| R1482 | 316-0102-00 | | | 1K ohm, 1/4 W, 10% |
| R1484 | 316-0471-00 | | | 470 ohm, 1/4 W, 10% |
| R1485 | 316-0221-00 | | | 220 ohm, 1/4 W, 10% |
| R1486 | 316-0226-00 | | | 22M ohm, 1/4 W, 10% |
| R1488 | 316-0102-00 | | | 1K ohm, 1/4 W, 10% |
| R1510 | 316-0103-00 | XB010400 | | 10K ohm, 1/4 W, 10% |
| R1511 | 315-0184-00 | B010100 | B010399 | 180K ohm, 1/4 W, 5% |
| R1511 | 316-0103-00 | B010400 | | 10K ohm, 1/4 W, 10% |
| R1512 | 316-0472-00 | XB010400 | | 4.7K ohm, 1/4 W, 10% |
| R1513 | 315-0222-00 | | | 2.2K ohm, 1/4 W, 5% |
| R1515 | 315-0102-00 | | | 1K ohm, 1/4 W, 5% |
| R1516 | 315-0102-00 | | | 1K ohm, 1/4 W, 5% |
| R1521 | 323-0269-00 | | | 6.19K ohm, 1/2 W, 1% |
| R1523 | 321-0292-00 | | | 10.7K ohm, 1/8 W, 1% |
| R1524 | 315-0202-00 | | | 2K ohm, 1/4 W, 5% |
| R1525 | 316-0102-00 | XB011052 | | 1K ohm, 1/4 W, 10% |
| R1527 | 315-0183-00 | | | 18K ohm, 1/4 W, 5% |
| R1528 | 303-0223-00 | | | 22K ohm, 1 W, 5% |
| R1532 | 315-0122-00 | | | 1.2K ohm, 1/4 W, 5% |
| R1533 | 315-0563-00 | | | 56K ohm, 1/4 W, 5% |
| R1534 | 307-0052-00 | | | 3 ohm, 1/2 W, 5% |
| R1537 | 321-0366-00 | | | 63.4K ohm, 1/8 W, 1% |
| R1538 | 311-1226-00 | | | 2.5K ohm, Var |
| R1539 | 321-0296-00 | | | 11.8K ohm, 1/8 W, 1% |
| R1543 | 321-0966-03 | | | 40K ohm, 1/8 W, 1/4% |
| R1544 | 321-0603-00 | | | 15K ohm, 1/8 W, 1/4% |
| R1546 | 315-0102-00 | | | 1K ohm, 1/4 W, 5% |
| R1547 | 315-0153-00 | | | 15K ohm, 1/4 W, 5% |
| R1549 | 308-0459-00 | | | 1.1 ohm, 3 W, WW, 5% |
| R1553 | 321-0775-03 | | | 45K ohm, 1/8 W, 1/4% |
| R1554 | 321-0774-03 | | | 4.5K ohm, 1/8 W, 1/4% |
| R1556 | 315-0102-00 | | | 1K ohm, 1/4 W, 5% |
| R1557 | 315-0512-00 | | | 5.1K ohm, 1/4 W, 5% |
| R1559 | 307-0093-00 | | | 1.2 ohm, 1/2 W, 5% |
| R1563 | 321-0274-00 | | | 6.98K ohm, 1/8 W, 1% |
| R1564 | 321-0967-03 | | | 55K ohm, 1/8 W, 1/4% |

| Ckt. No. | Tektronix Part No. | Serial/Model No. Eff | Disc | Description |
|------------------|--------------------|----------------------|------|--|
| RESISTORS (cont) | | | | |
| | R1565 | 321-0962-03 | | 8K ohm, 1/8 W, 1/4% |
| | R1566 | 315-0301-00 | | 300 ohm, 1/4 W, 5% |
| | R1567 | 315-0242-00 | | 2.4K ohm, 1/4 W, 5% |
| | R1569 | 308-0459-00 | | 1.1 ohm, 3 W, WW, 5% |
| | R1570 | 311-1373-00 | | 5K ohm, Var |
| | R1571 | 315-0392-00 | | 3.9K ohm, 1/4 W, 5% |
| | R1581 | 315-0153-00 | | 15K ohm, 1/4 W, 5% |
| | R1584 | 321-0359-00 | | 53.6K ohm, 1/8 W, 1% |
| | R1585 | 321-0280-00 | | 8.06K ohm, 1/8 W, 1% |
| | R1586 | 316-0104-00 | | 100K ohm, 1/4 W, 10% |
| | R1587 | 316-0104-00 | | 100K ohm, 1/4 W, 10% |
| | R1589 | 315-0102-00 | | 1K ohm, 1/4 W, 5% |
| | R1591 | 315-0912-00 | | 9.1K ohm, 1/4 W, 5% |
| | R1592 | 315-0473-00 | | 47K ohm, 1/4 W, 5% |
| | R1593 | 315-0822-00 | | 8.2K ohm, 1/4 W, 5% |
| | R1594 | 315-0513-00 | | 51K ohm, 1/4 W, 5% |
| | R1596 | 315-0512-00 | | 5.1K ohm, 1/4 W, 5% |
| | R1597 | 311-1221-00 | | 50 ohm, Var |
| | R1598 | 321-0107-00 | | 127 ohm, 1/8 W, 1% |
| | R1599 | 321-0001-00 | | 10 ohm, 1/8 W, 1% |
| | R1691 | 303-0150-00 | | 15 ohm, 1 W, 5% |
| | R1692 | 321-0062-00 | | 43.2 ohm, 1/8 W, 1% |
| | R1693 | 323-0140-00 | | 280 ohm, 1/2 W, 1% |
| | R1694 | 323-0140-00 | | 180 ohm, 1/2 W, 1% |
| | R1695 | 321-0228-00 | | 2.32K ohm, 1/8 W, 1% |
| | RT1696 | 307-0124-00 | | 5K ohm, Thermal |
| | R1697 | 321-0201-00 | | 1.21K ohm, 1/8 W, 1% |
| | R1698 | 315-0363-00 | | 36K ohm, 1/4 W, 5% |
| SWITCHES | | | | |
| | S5 ¹ | | | Input Coupling CH 1 |
| | S10 | 105-0342-00 | | Actuator, Cam, VOLTS/DIV CH 1 |
| | S55 ¹ | | | Input Coupling CH 2 |
| | S60 | 105-0342-00 | | Actuator, Cam, VOLTS/DIV CH 2 |
| | S112 ² | | | |
| | S212 ³ | | | |
| | S225 | 260-1208-00 | | Push-push, INVERT |
| | S338A | 105-0423-00 | | Actuator assy, Slide, BANDWIDTH LIMIT |
| | S338B | 105-0421-00 | | Actuator assy, Slide, MOMENTARY |
| | S350 | 260-1424-01 | | Push, VERT MODE |
| | S400 | 260-1421-00 | | Pushbutton, BEAM FIND |
| | S510 | 105-0401-00 | | Actuator assy, Slide, B (DLY'D) SOURCE |
| | S515 | 105-0399-00 | | Actuator assy, Slide, B (DLY'D) COUPLING |
| | S530 ⁴ | | | |
| | S610 | 105-0400-00 | | Actuator assy, A SOURCE |
| | S615 | 105-0399-00 | | Actuator assy, A COUPLING |

¹See Mechanical Parts List for replacement parts.

²Furnished as a unit with R112.

³Furnished as a unit with R212.

⁴Furnished as a unit with R530.

| Ckt. No. | Tektronix Part No. | Serial/Model No. Eff | Disc | Description |
|-----------------------|--------------------|----------------------|----------|---|
| SWITCHES (cont) | | | | |
| S630 ¹ | | | | A TRIGGER SLOPE |
| S1100 | 260-1422-00 | | | Pushbutton, TRIG MODE |
| S1120 | 260-1423-00 | | | Pushbutton, HORIZ DISPLAY |
| S1140 ² | | | | |
| S1150 | 105-0366-00 | | | Actuator assy, Cam, TIME/CM |
| S1155A,B ³ | | | | |
| S1239 | 260-1208-00 | | | Push-push, X10 MAG |
| S1501 | 260-0834-00 | | | Toggle, POWER |
| S1502 | 260-0638-00 | | | Thermostatic, open 75 deg. C, close 55 deg. C |
| S1503 | 260-1300-01 | | | Slide, LINE |
| TRANSFORMERS | | | | |
| T354 | 120-0366-00 | | | Toroid, 2 windings |
| T1420 ⁴ | 120-0800-00 | | | HV Power |
| T1420 ⁴ | 120-0800-01 | | | HV Power |
| T1501 | 120-0798-00 | | | LV Power |
| INTEGRATED CIRCUITS | | | | |
| U440 | 155-0077-00 | B010100 | B039999X | Hybrid |
| U540 | 155-0032-00 | | | Monolithic, input pre-amplifier |
| U640 | 155-0032-00 | | | Monolithic, input pre-amplifier |
| U870 | 155-0049-00 | | | Monolithic, sweep control |
| U1524 | 156-0158-00 | | | Dual operational amplifier, N5558V |
| U1554 | 156-0158-00 | | | Dual operational amplifier, N5558V |
| U1690 | 156-0281-00 | | | 4 transistor array, MPQ2221 |
| VOLTAGE MULTIPLIER | | | | |
| U1432 | 152-0552-00 | | | Silicon, voltage multiplier |
| ELECTRON TUBES | | | | |
| V1440 | 154-0676-00 | B010100 | B010499 | CRT |
| V1440 | 154-0676-05 | B010500 | | CRT |

¹Furnished as a unit with R630.

²Furnished as a unit with R1140.

³Furnished as a unit with R1155.

⁴Either of these transformers may be used in the instrument.

DIAGRAMS AND CIRCUIT BOARD ILLUSTRATIONS

Symbols and Reference Designators

Electrical components shown on the diagrams are in the following units unless noted otherwise:

- Capacitors = Values one or greater are in picofarads (pF).
Values less than one are in microfarads (μF).
- Resistors = Ohms (Ω)

Symbols used on the diagrams are based on USA Standard Y32.2-1967.

Logic symbology is based on MIL-STD-806B in terms of positive logic. Logic symbols depict the logic function performed and may differ from the manufacturer's data.

The following special symbols are used on the diagrams:

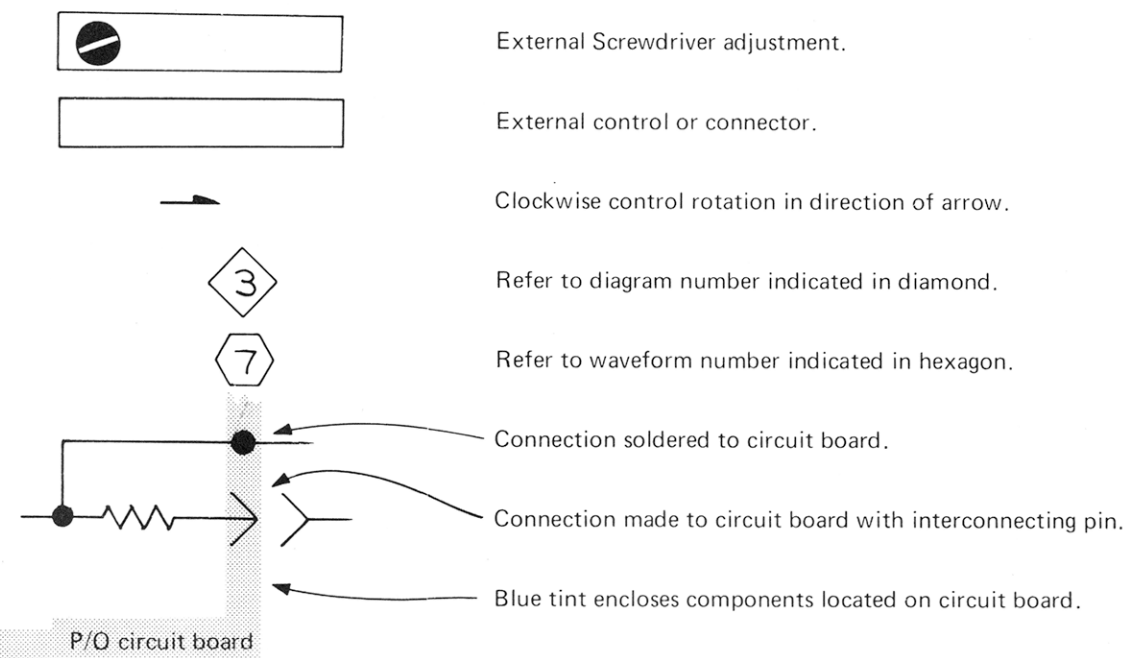

The following prefix letters are used as reference designators to identify components or assemblies on the diagrams.

- | | |
|--|--|
| A Assembly, separable or repairable (circuit board, etc.) | LR Inductor/resistor combination |
| AT Attenuator, fixed or variable | M Meter |
| B Motor | Q Transistor or silicon-controlled rectifier |
| BT Battery | P Connector, movable portion |
| C Capacitor, fixed or variable | R Resistor, fixed or variable |
| CR Diode, signal or rectifier | RT Thermistor |
| DL Delay line | S Switch |
| DS Indicating device (lamp) | T Transformer |
| F Fuse | TP Test point |
| FL Filter | U Assembly, inseparable or non-repairable (integrated circuit, etc.) |
| H Heat dissipating device (heat sink, heat radiator, etc.) | V Electron tube |
| HR Heater | VR Voltage regulator (zener diode, etc.) |
| J Connector, stationary portion | Y Crystal |
| K Relay | |
| L Inductor, fixed or variable | |

Diagrams-465

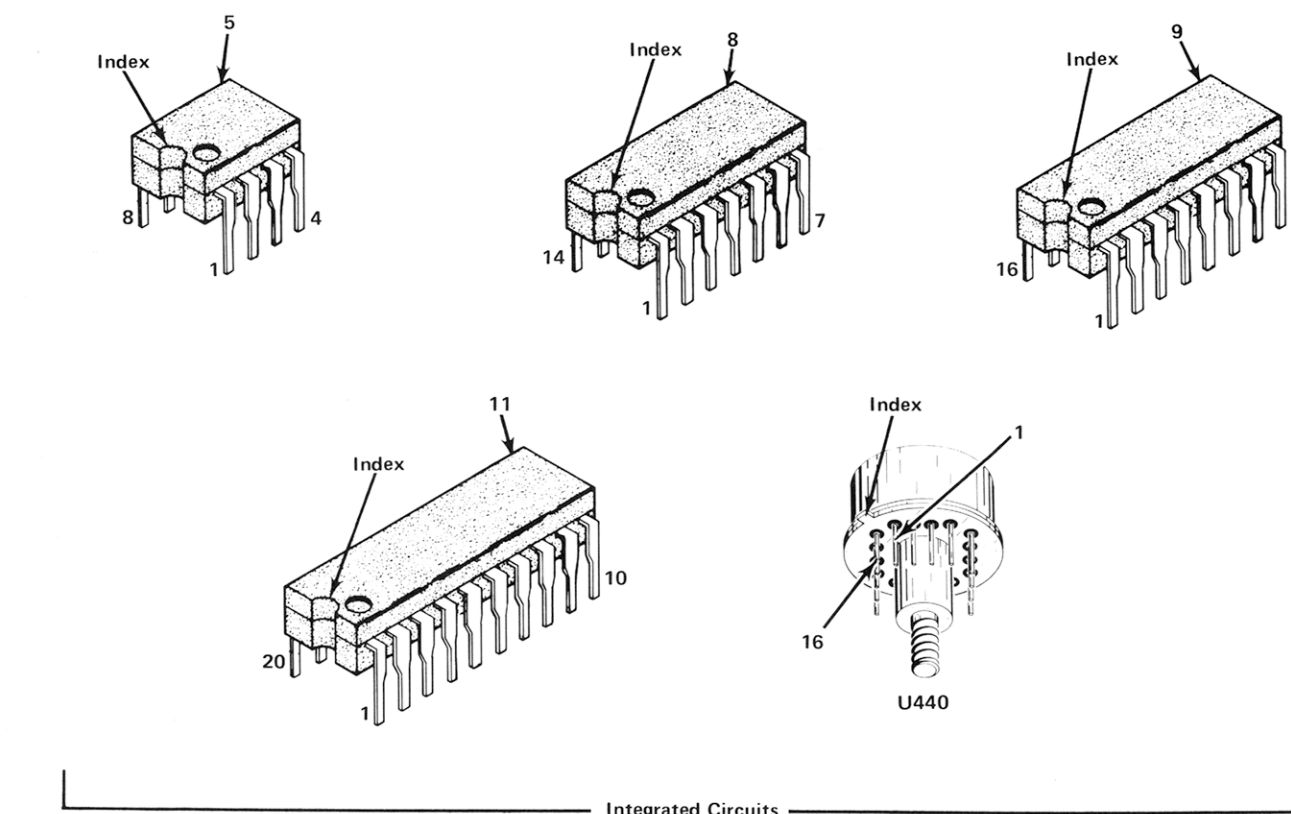
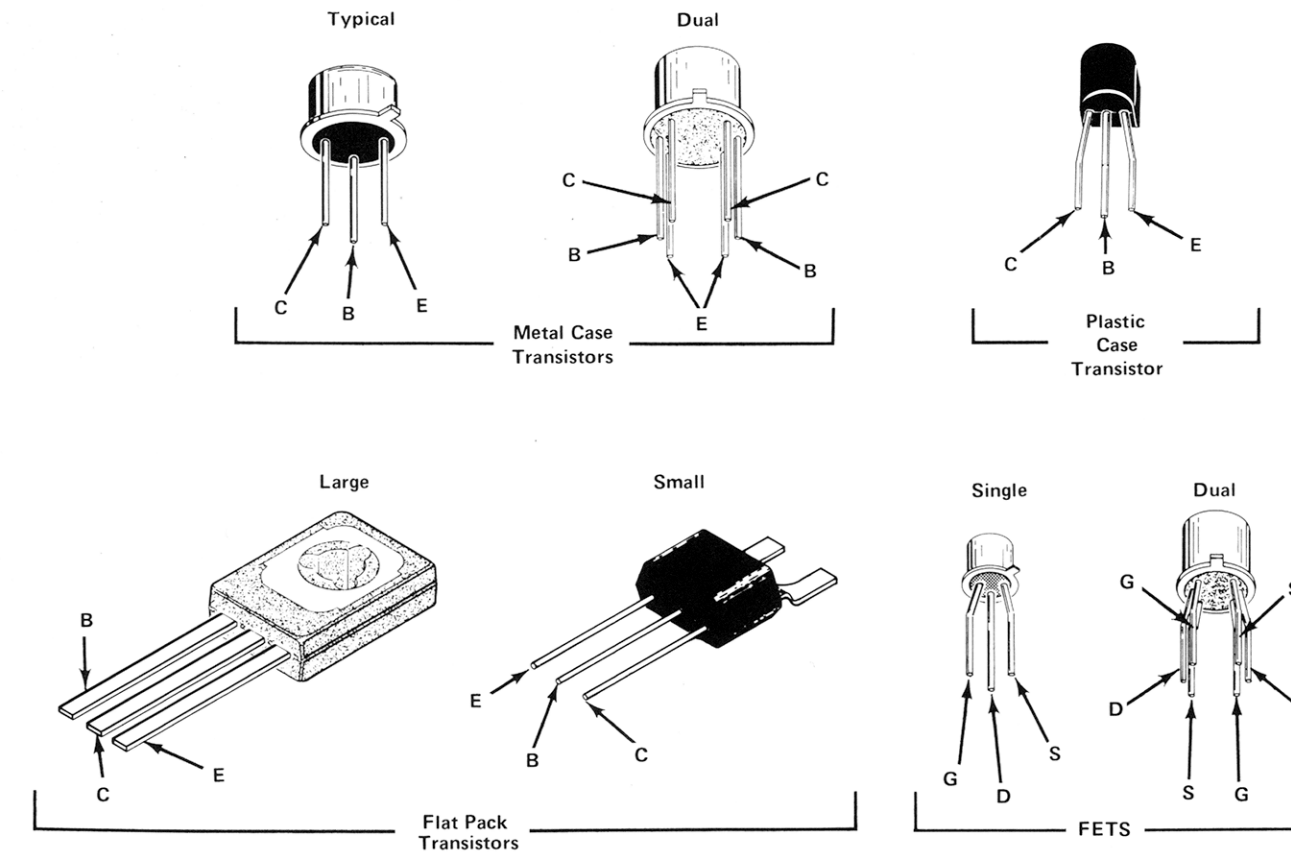

Fig. 7-1. Lead configuration for semiconductors used in this instrument.

Diagrams-465

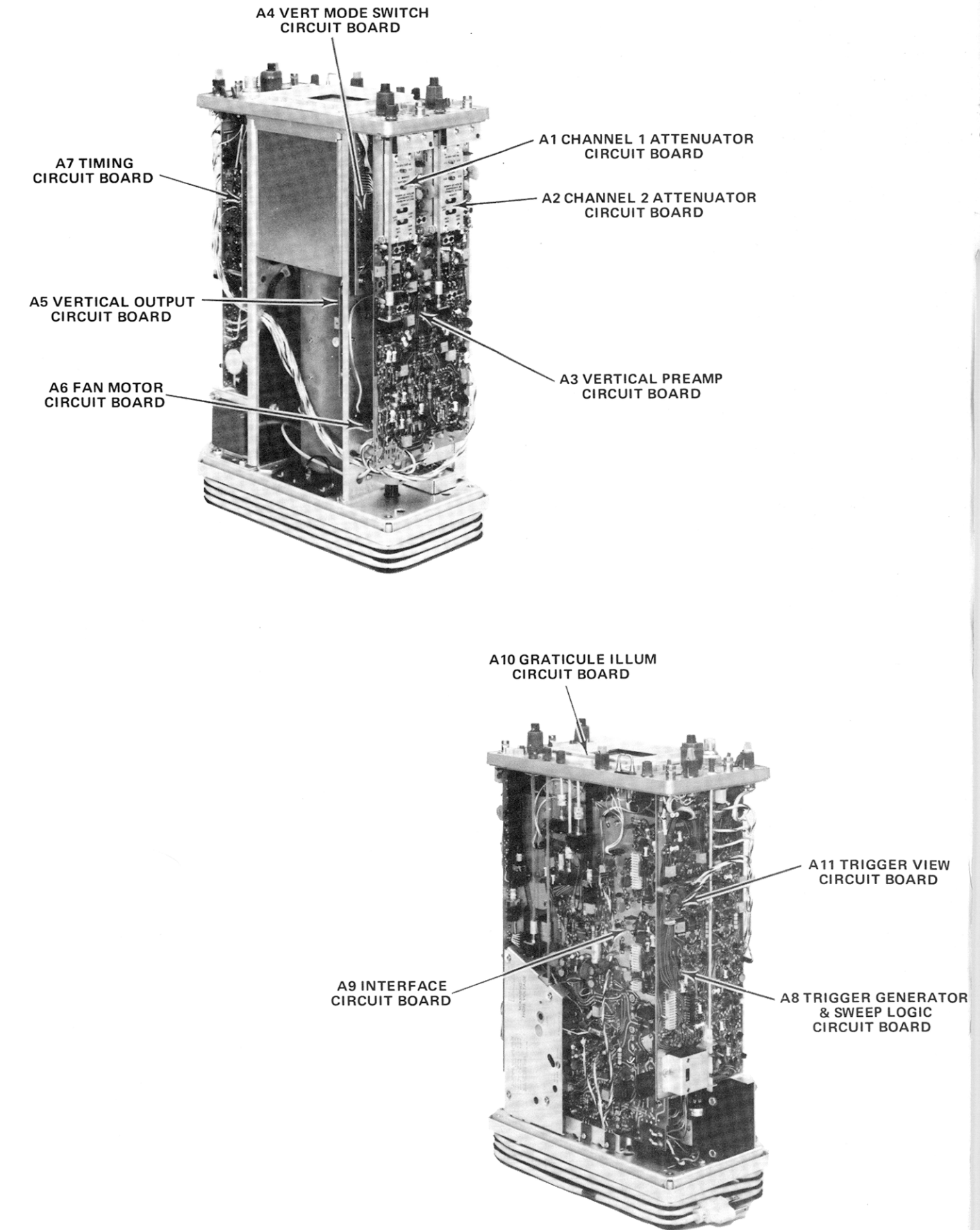
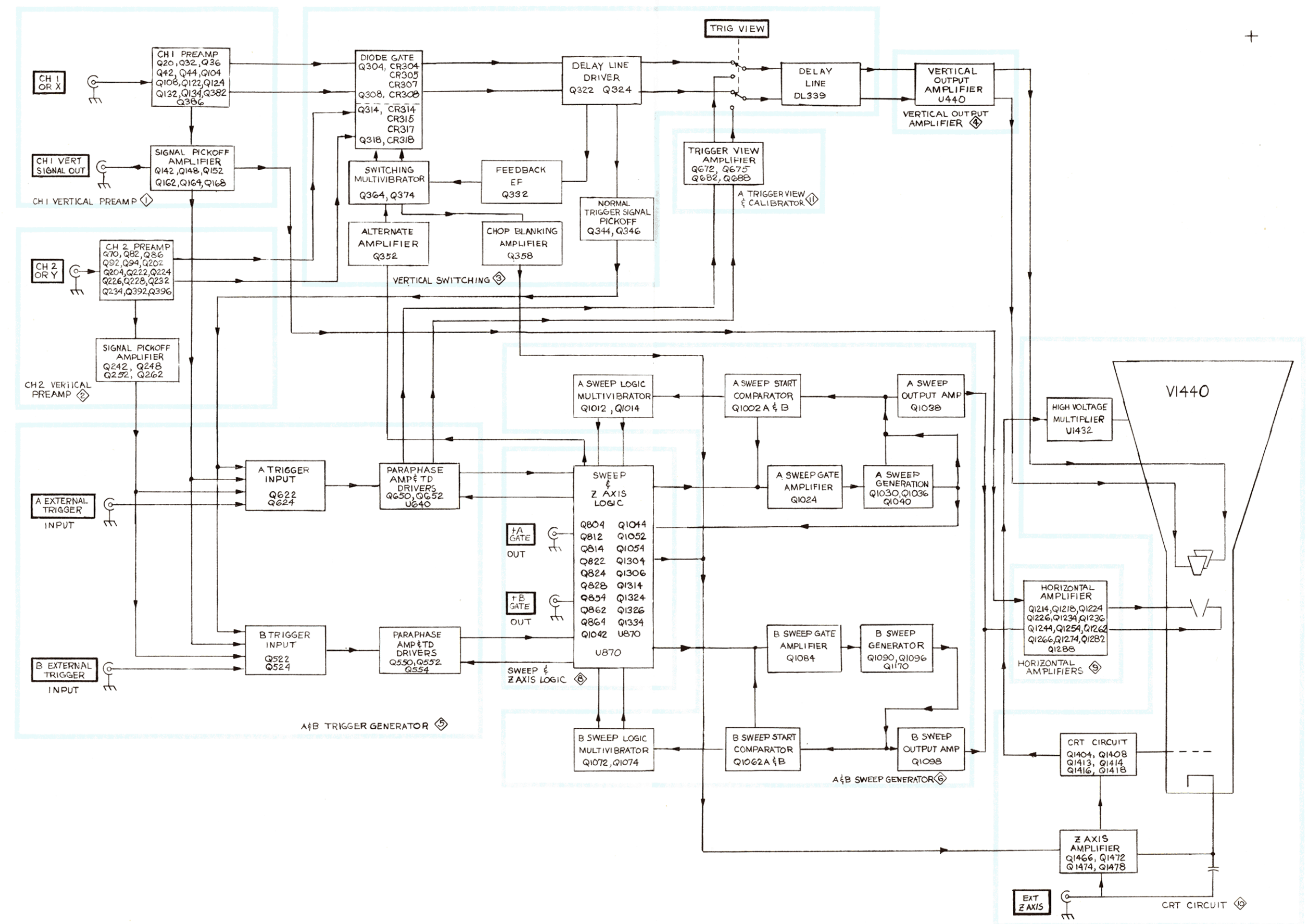
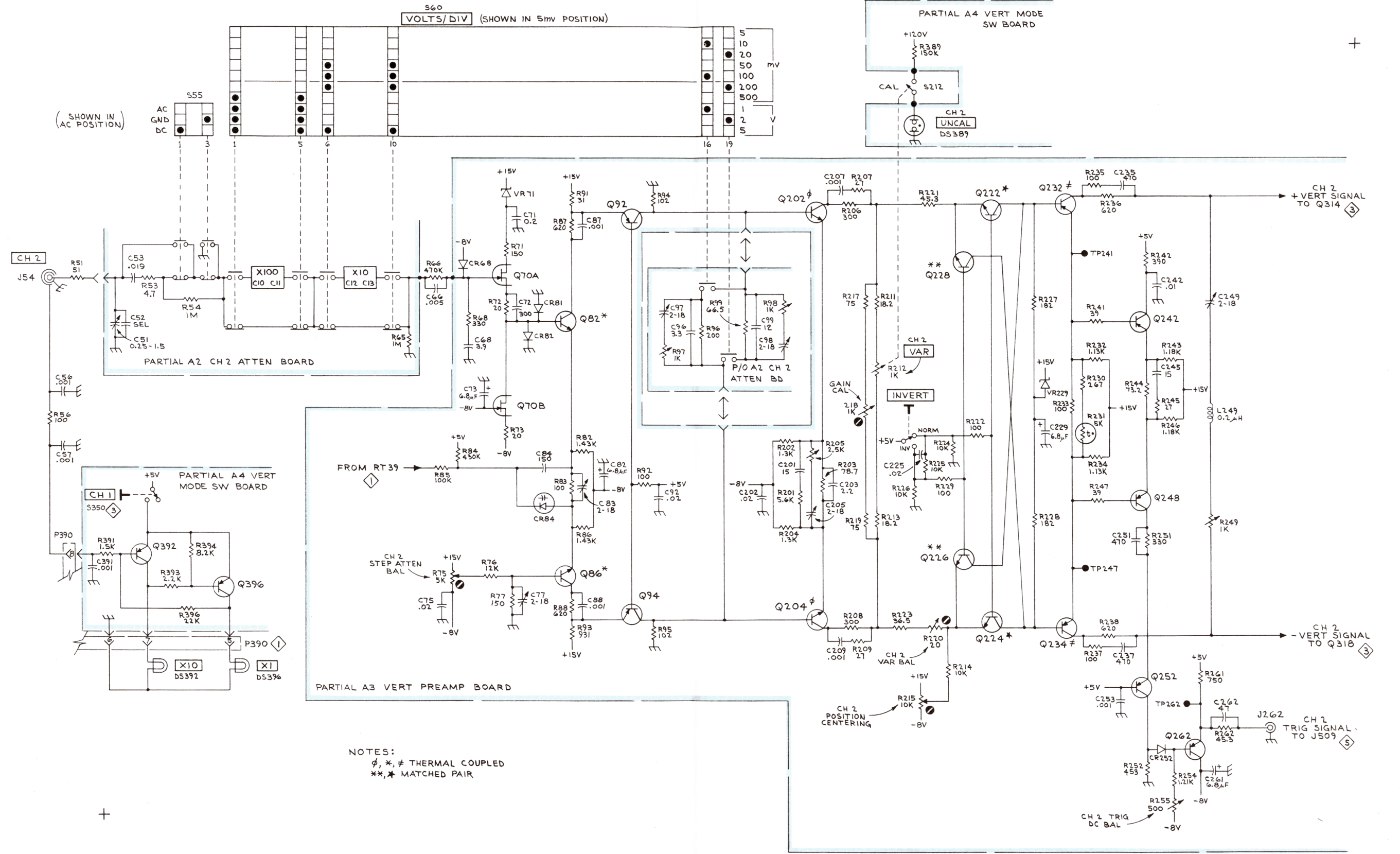

Fig. 7-2. Location of circuit boards in the 465.





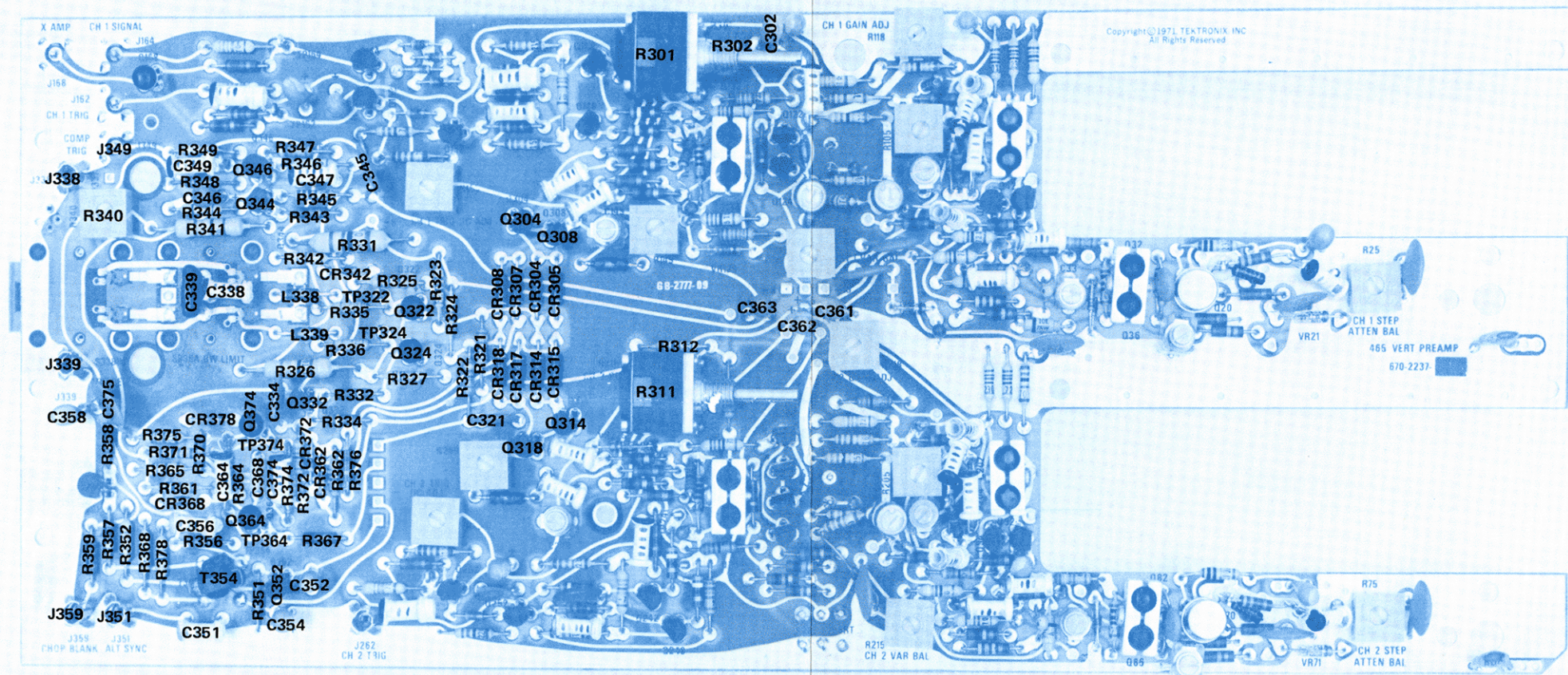
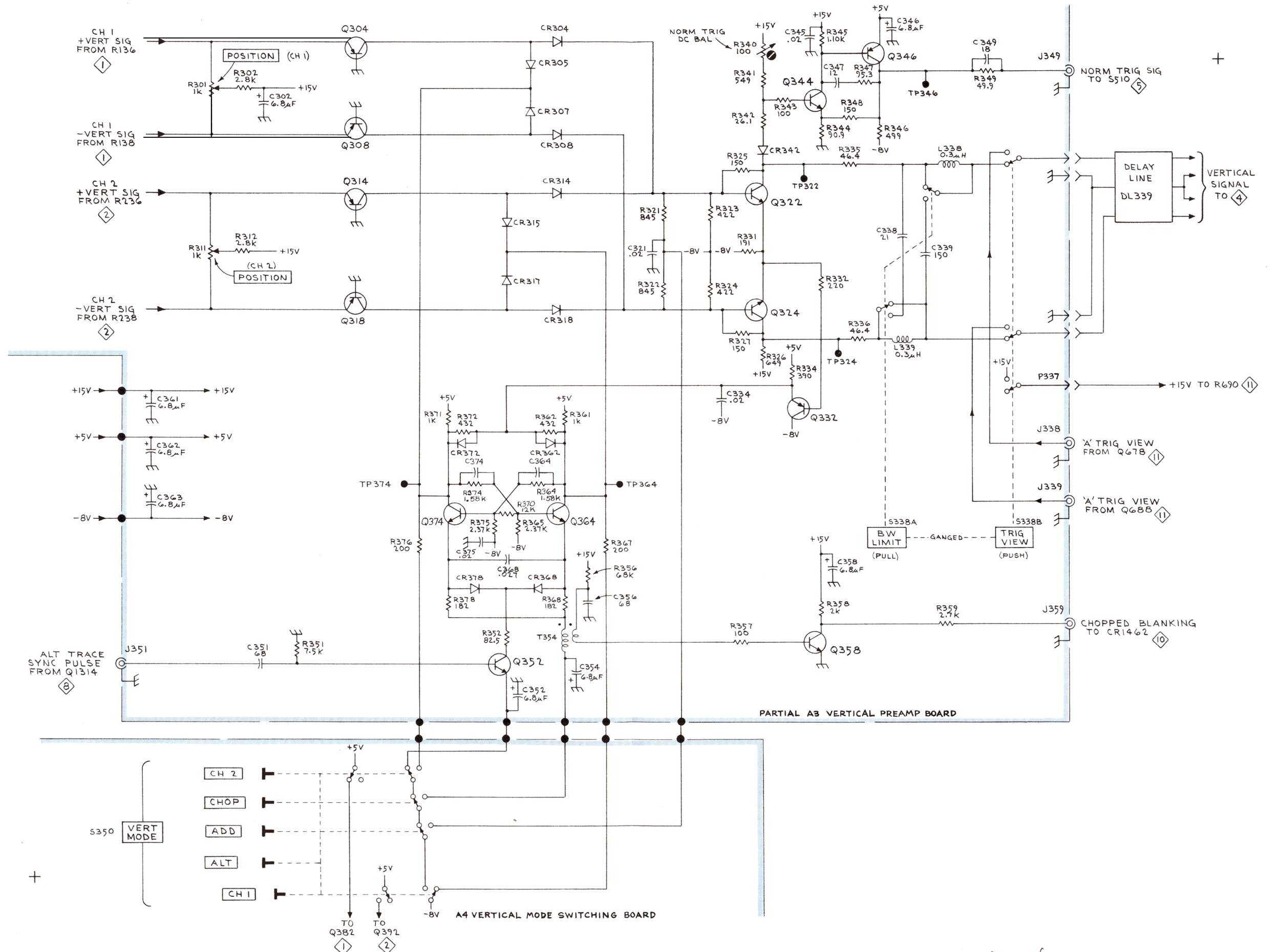
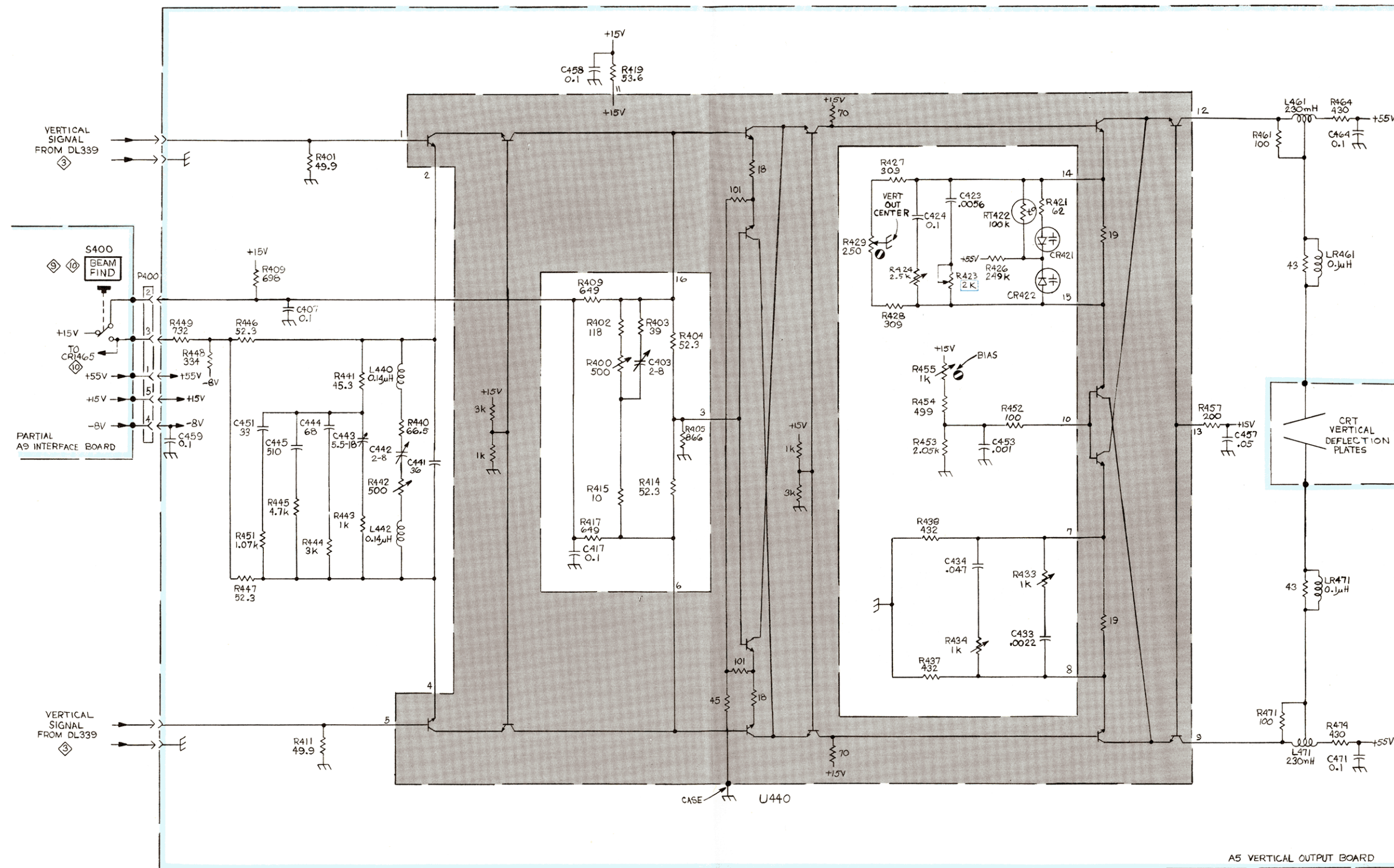

Fig. 7-9. P/O A3 Vertical Preamp circuit board.





SEE PARTS LIST FOR EARLIER VALUES AND SERIAL NUMBER RANGES OF PARTS MARKED WITH BLUE OUTLINE.

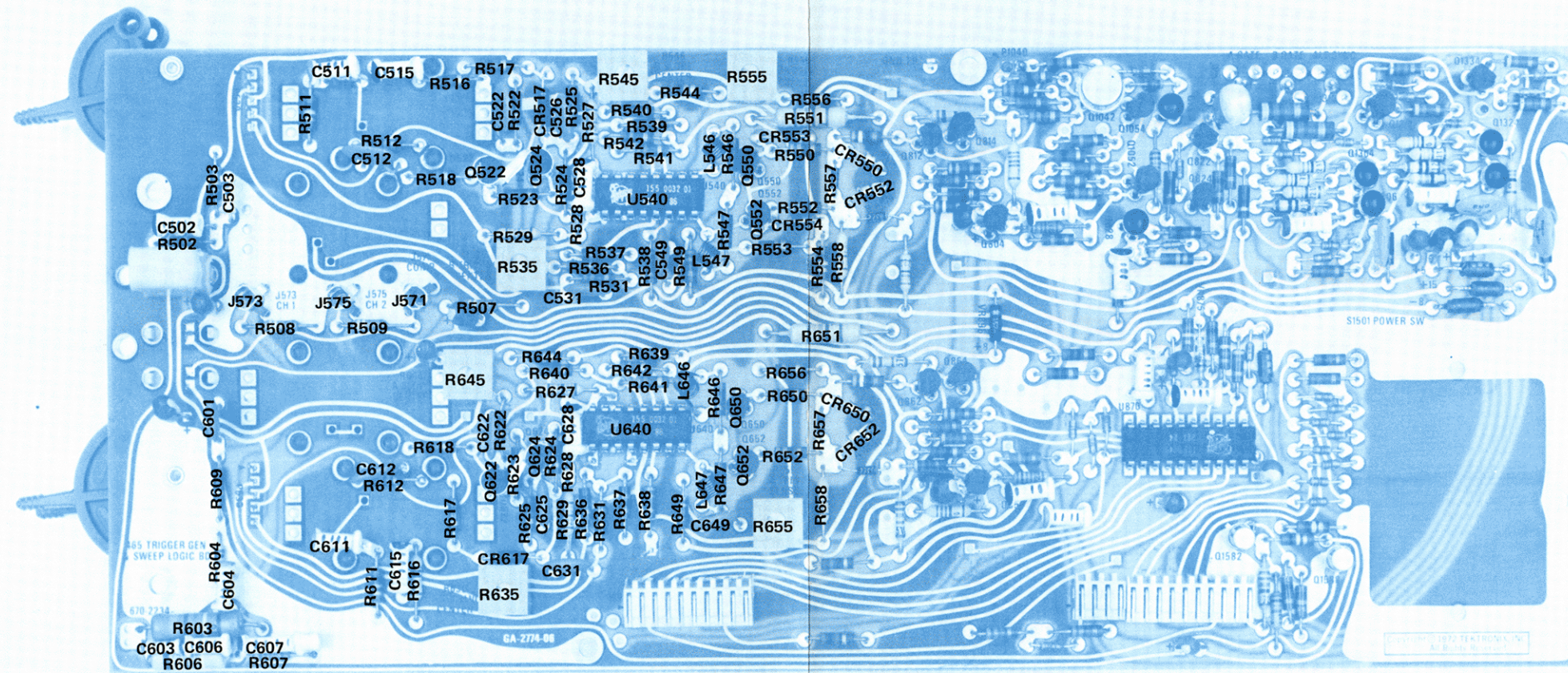
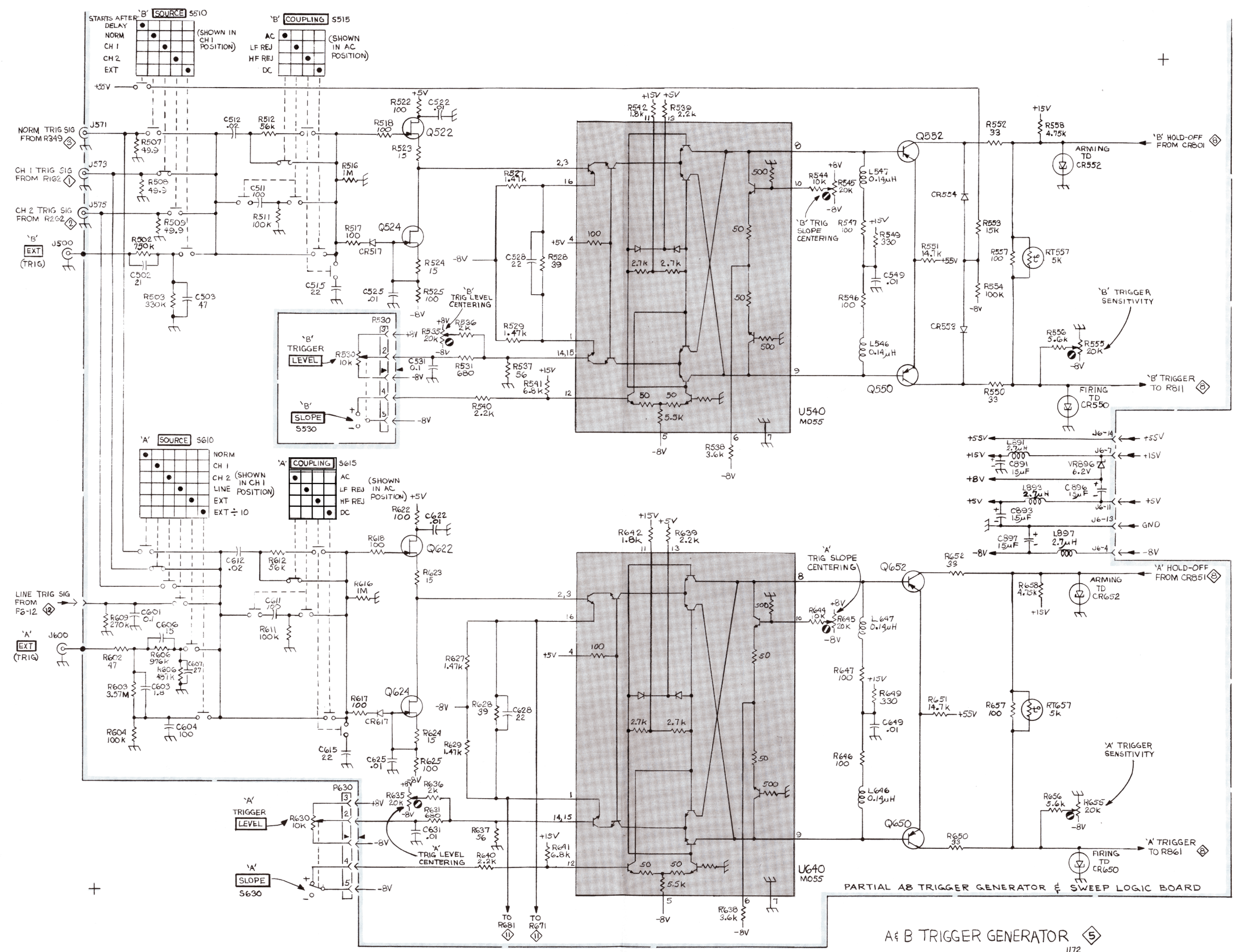
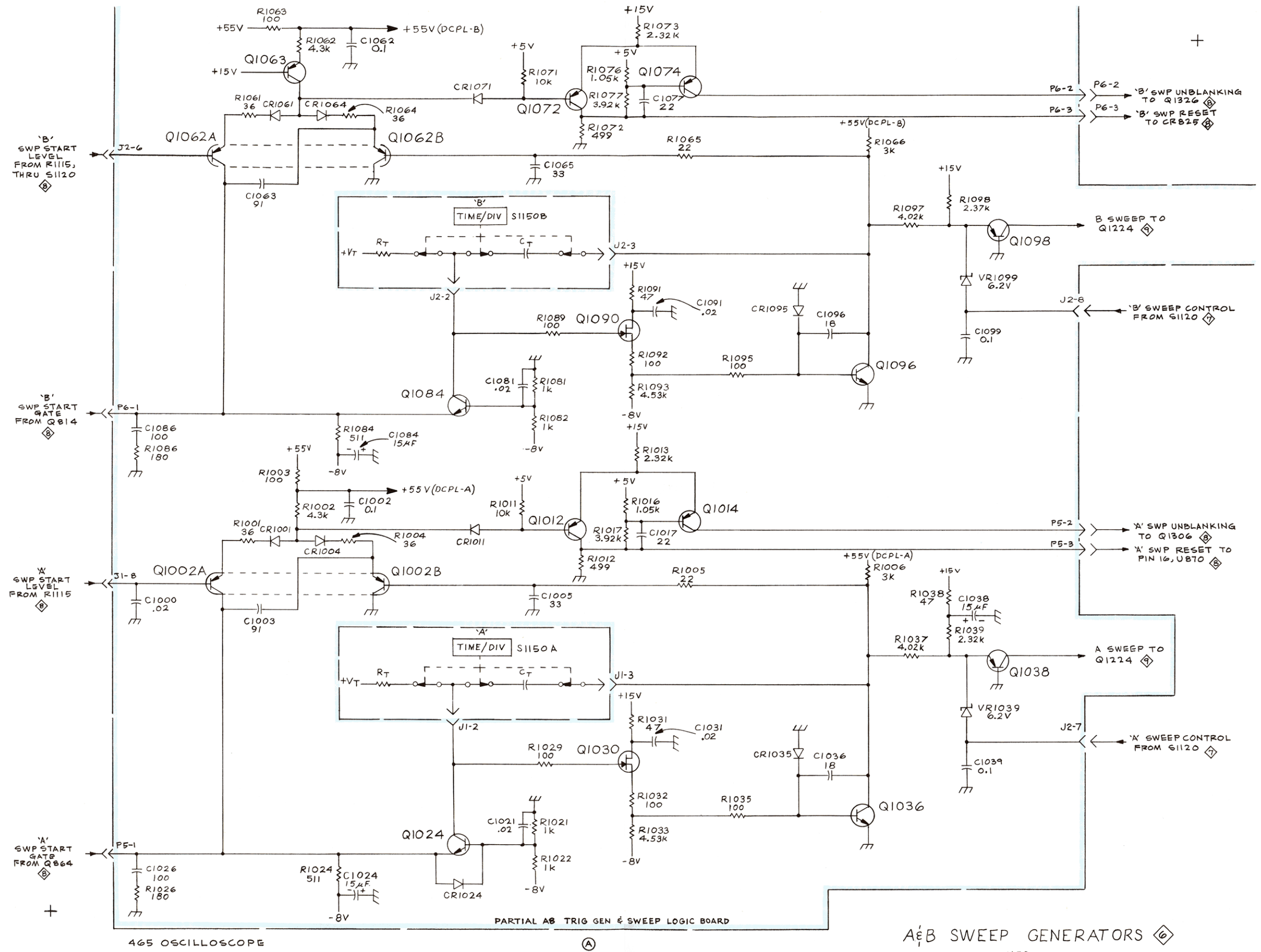

Fig. 7-11. P/O A8 Trigger Generator & Sweep Logic circuit board.





465 OSCILLOSCOPE

(A)

A & B SWEEP GENERATORS

MEB
0872

GENERATOR

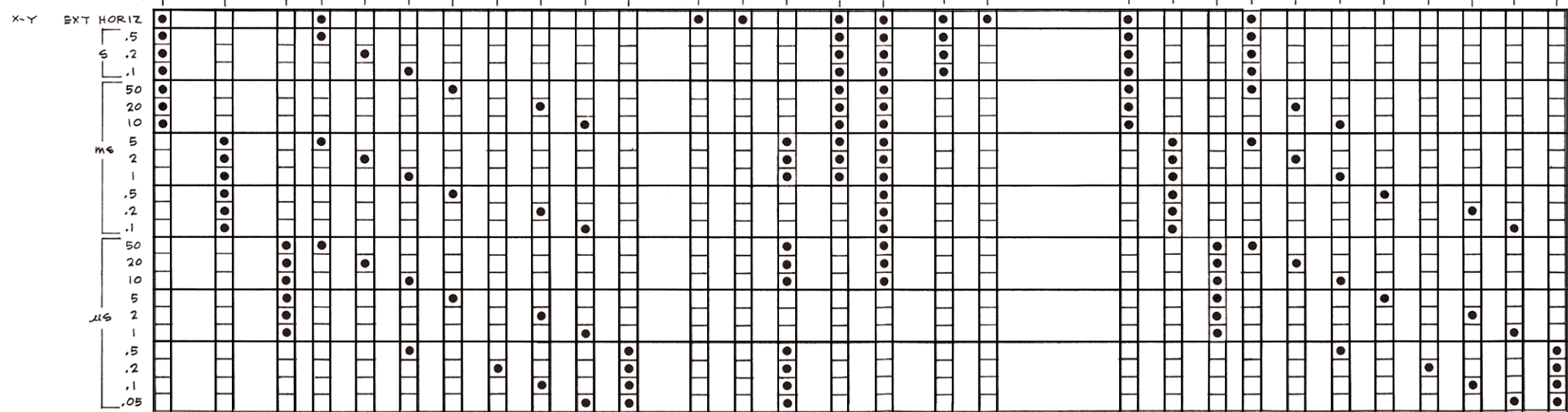
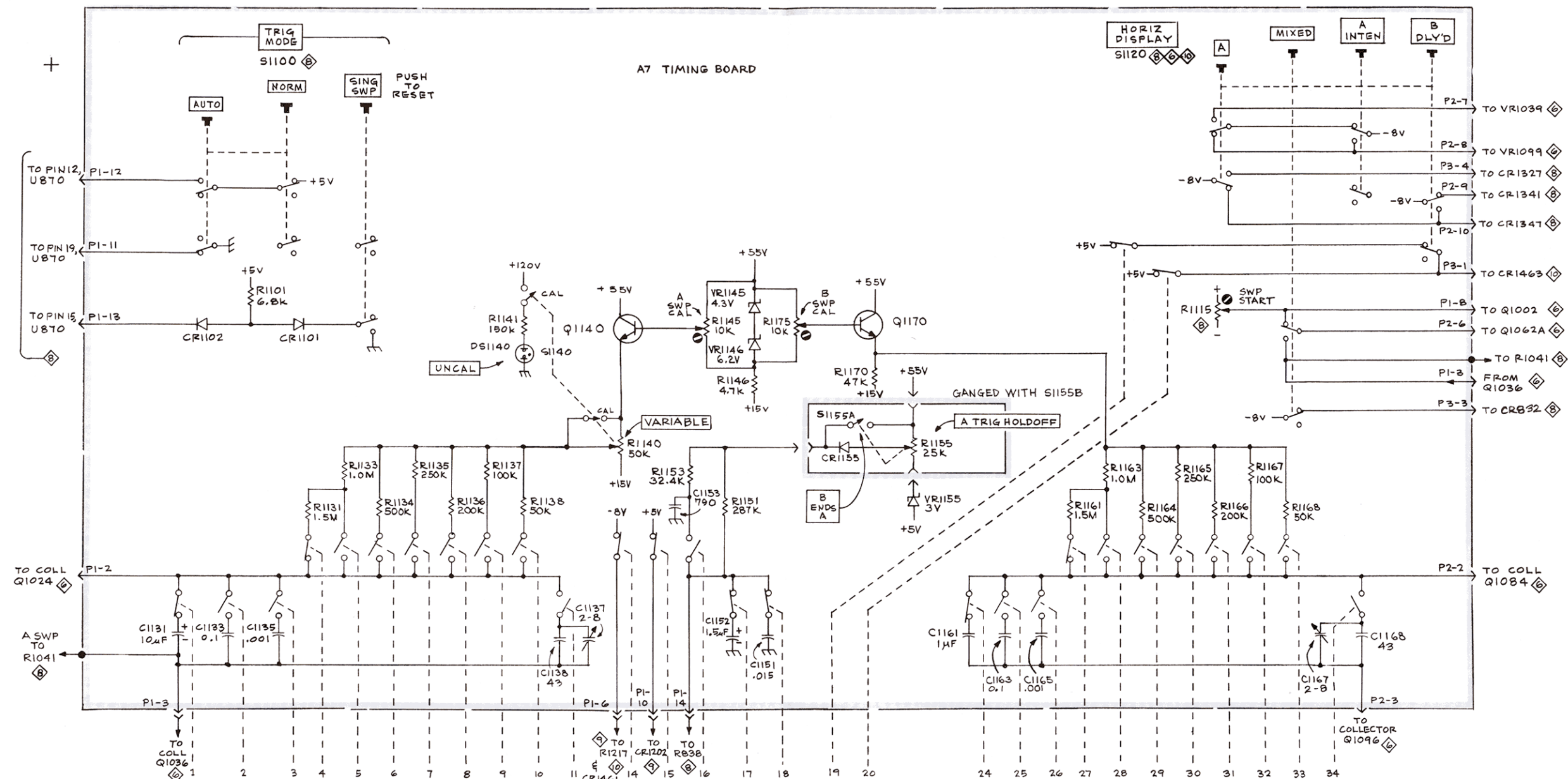

465 OSCILLOSCOPE

A AND B
TIME / DIV
AND DELAY TIME
5150
(SWITCH SHOWN IN EXT HORIZ POSITION)
A

A & B TIMING SWITCH

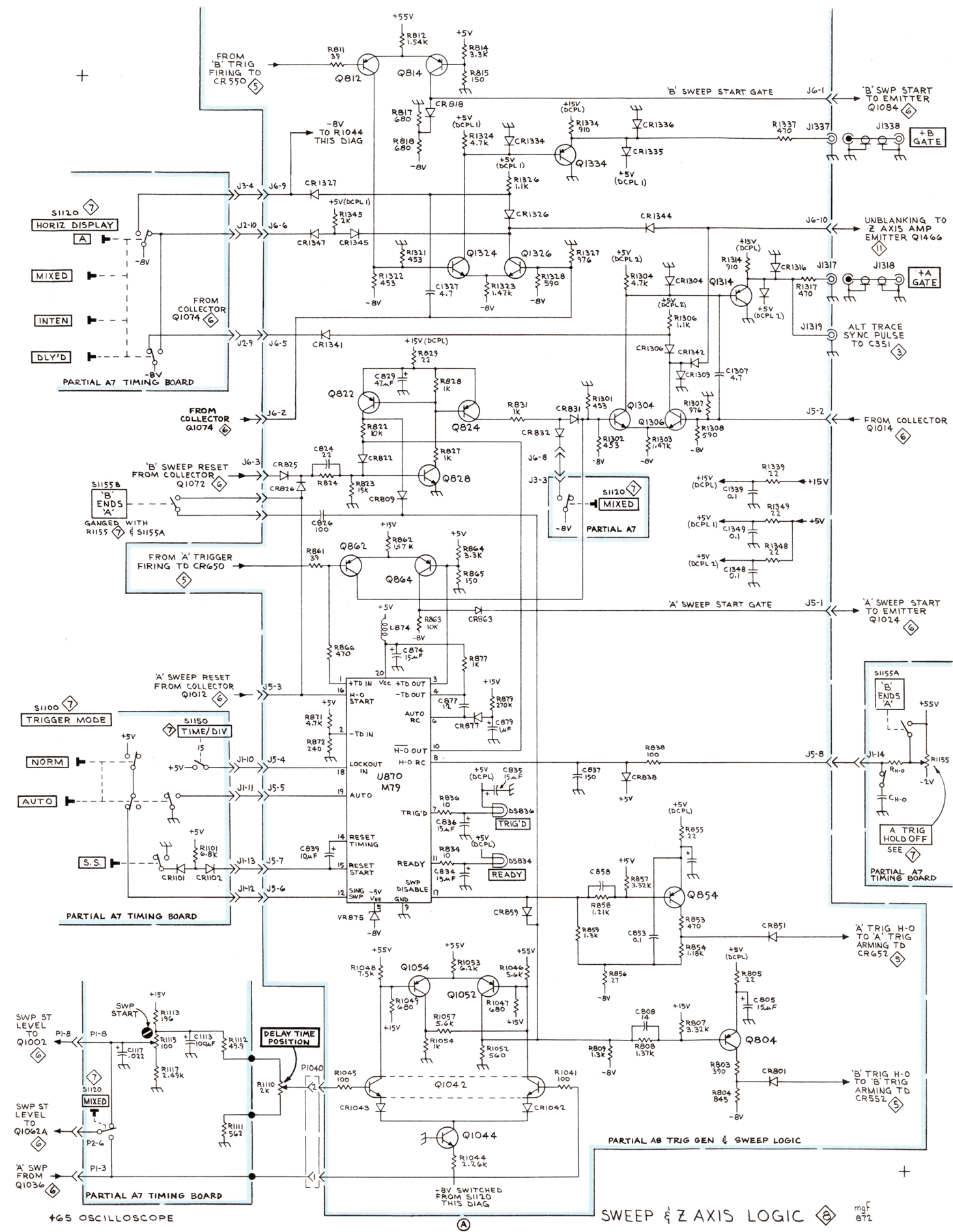

#65 OSCILLOSCOPE

SWEEP & Z AXIS LOGIC

mgf 871

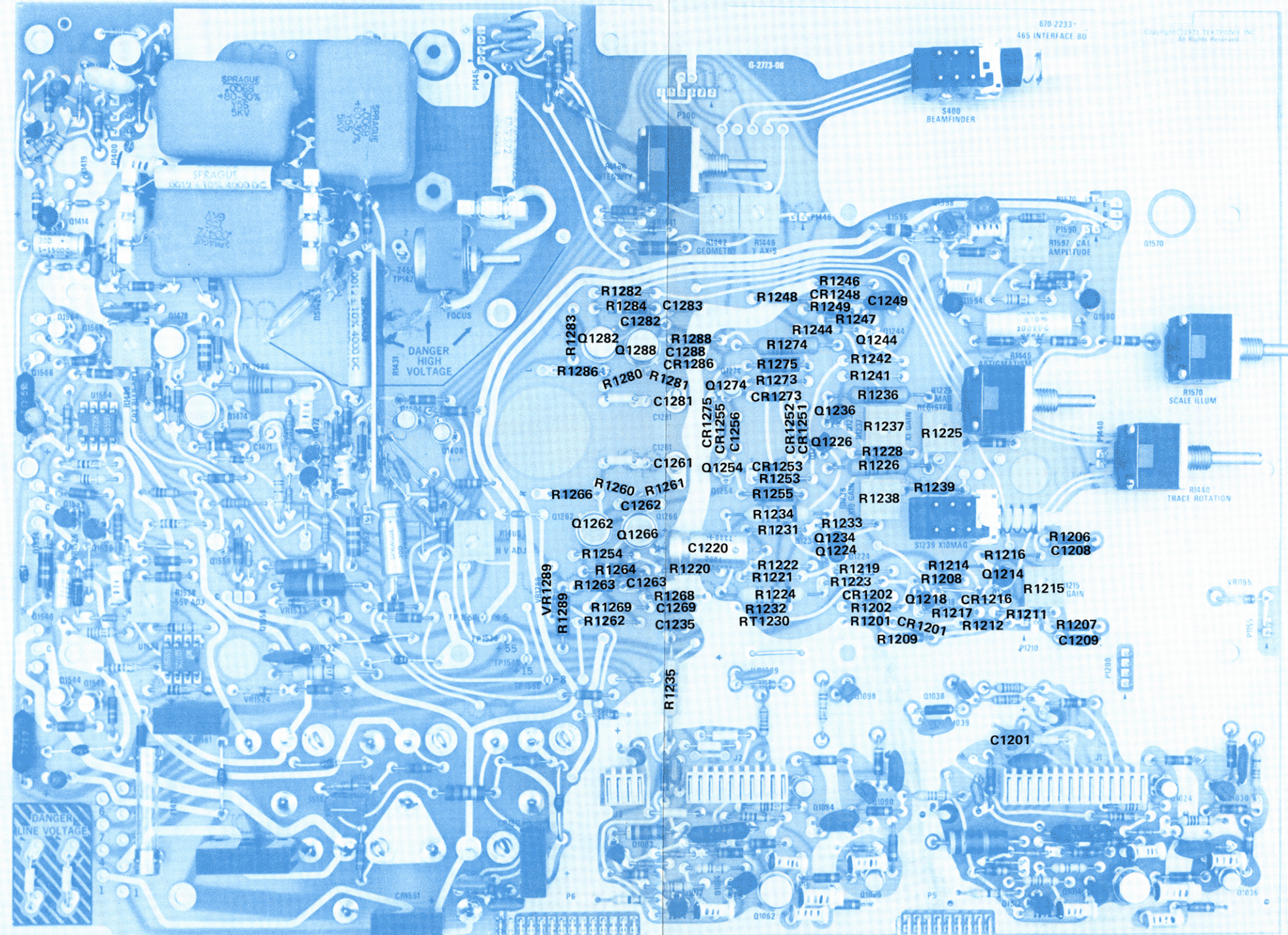
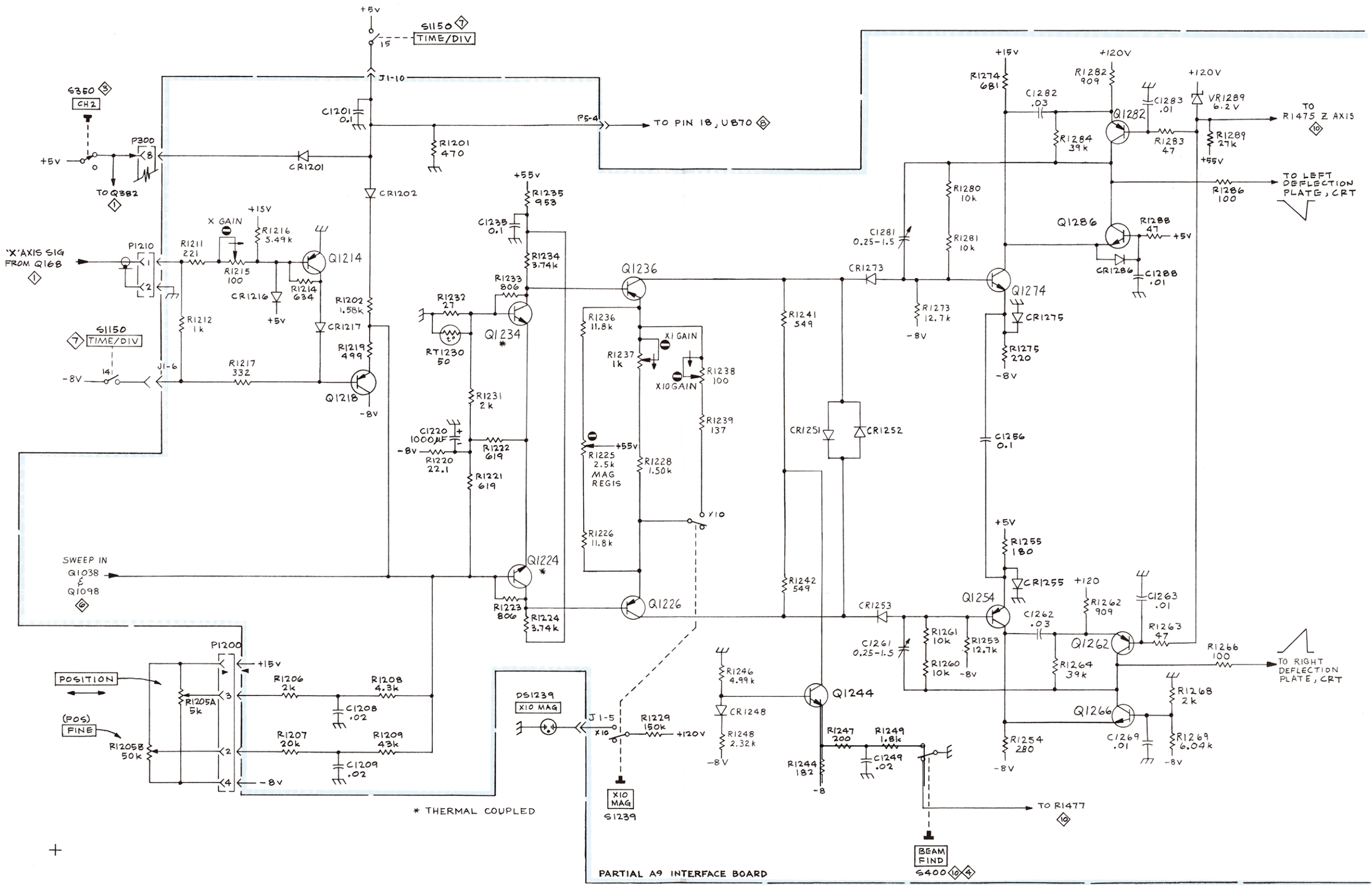

Fig. 7-16. P/O A9 Interface circuit board.



465 OSCILLOSCOPE

PARTIAL A9 INTERFACE BOARD

HORIZONTAL AMPLIFIER

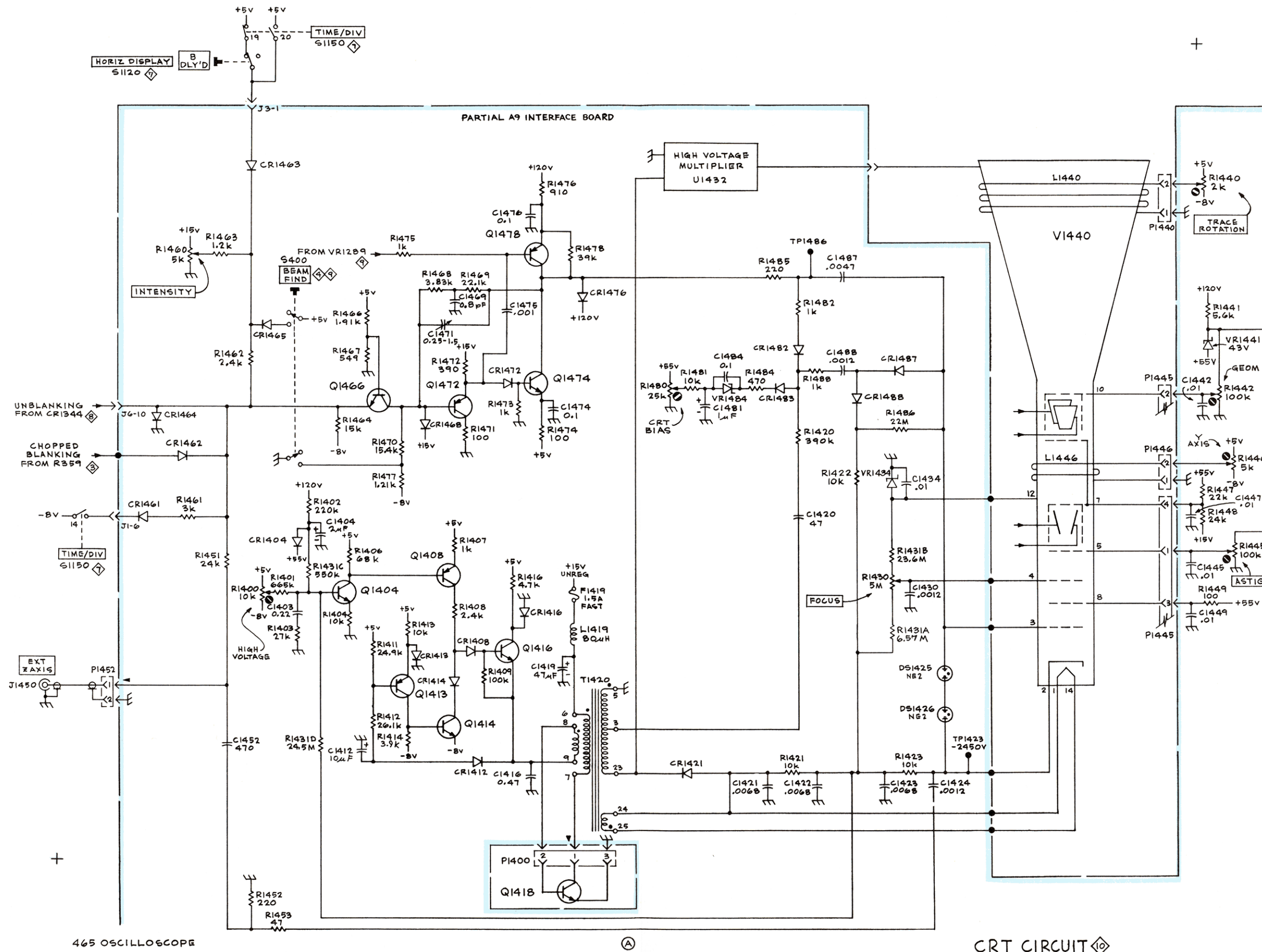

465 OSCILLOSCOPE

CRT CIRCUIT

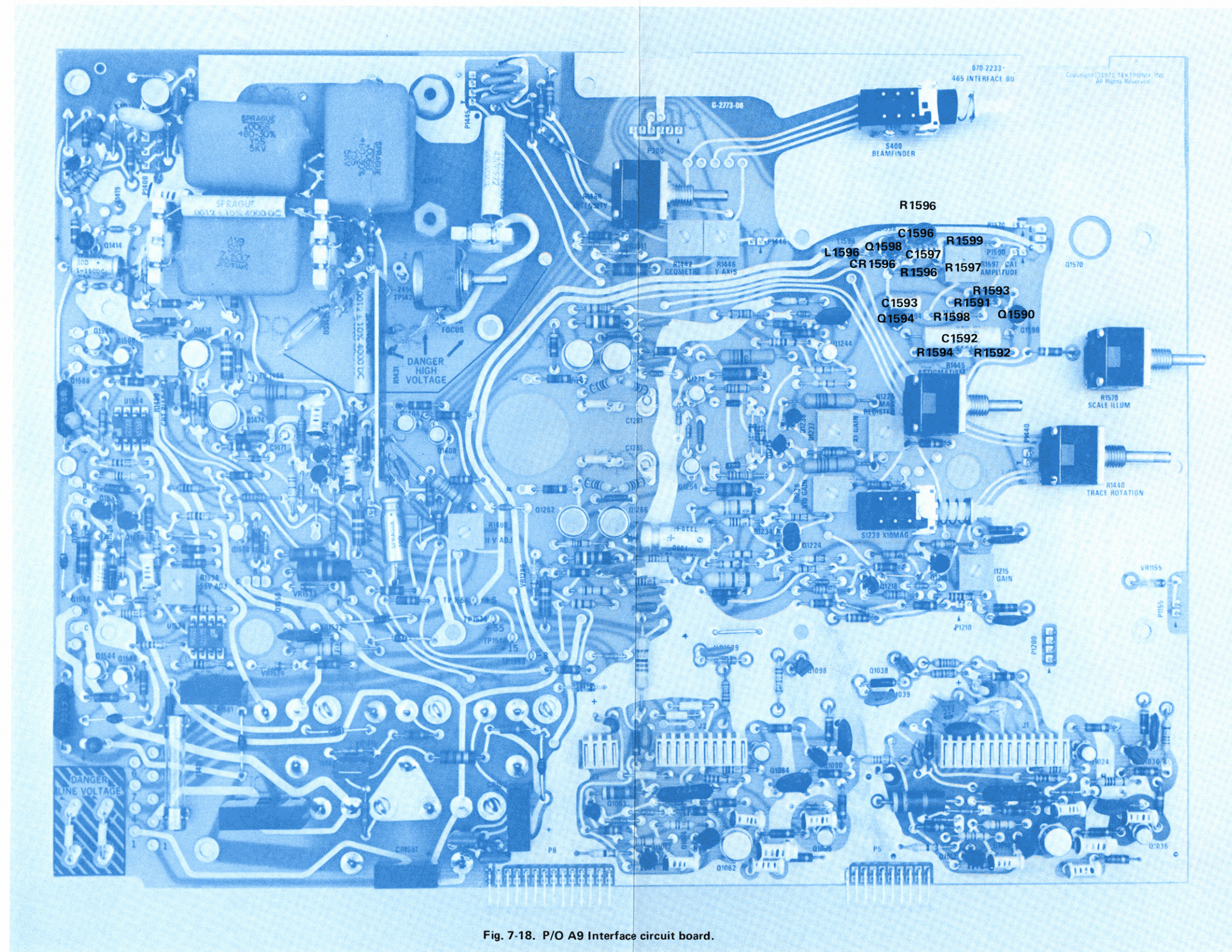

Fig. 7-18. P/O A9 Interface circuit board.

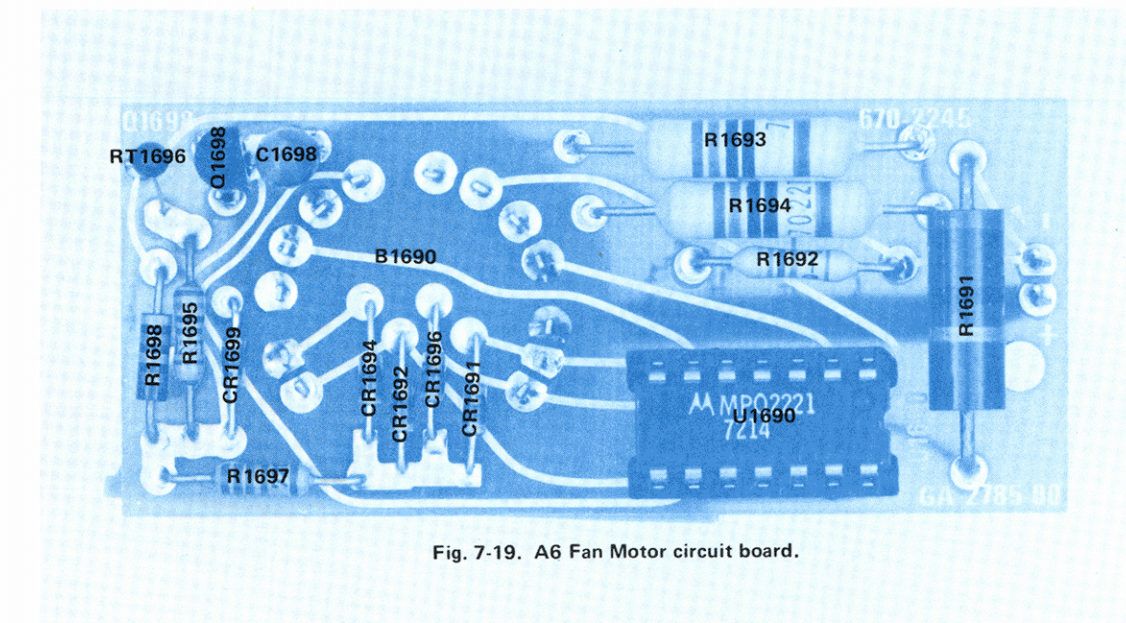

Fig. 7-19. A6 Fan Motor circuit board.

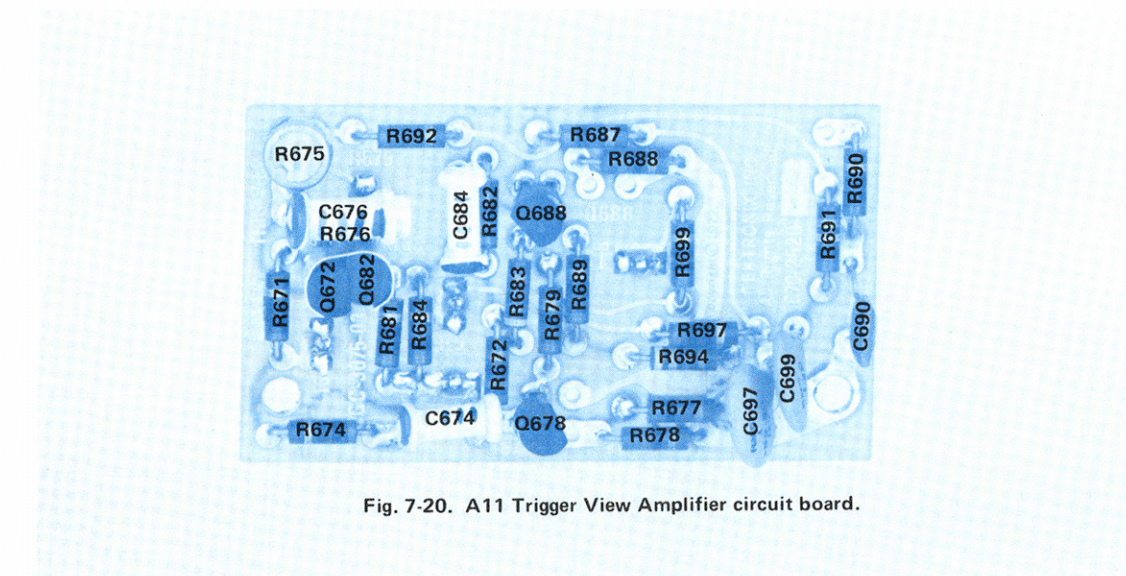
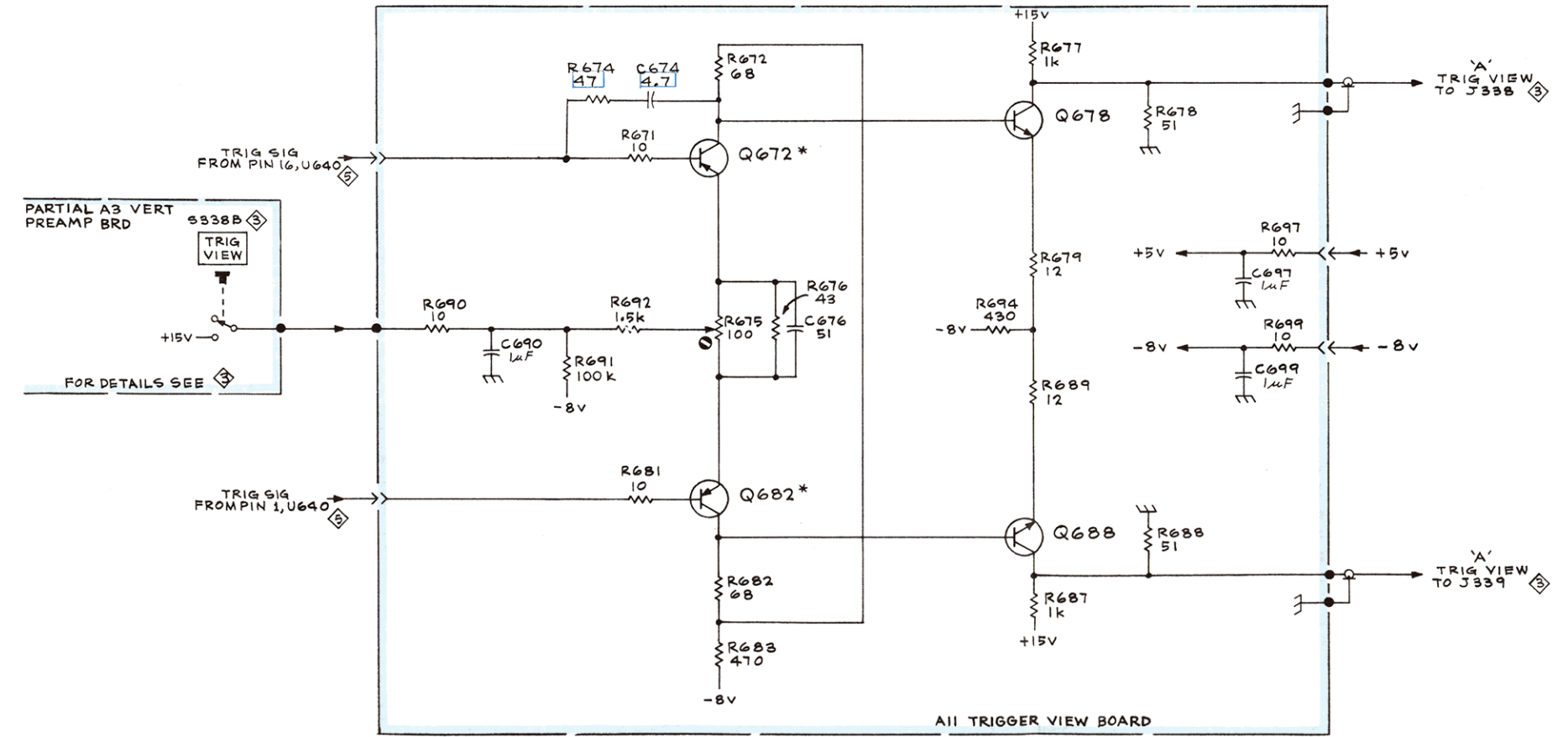
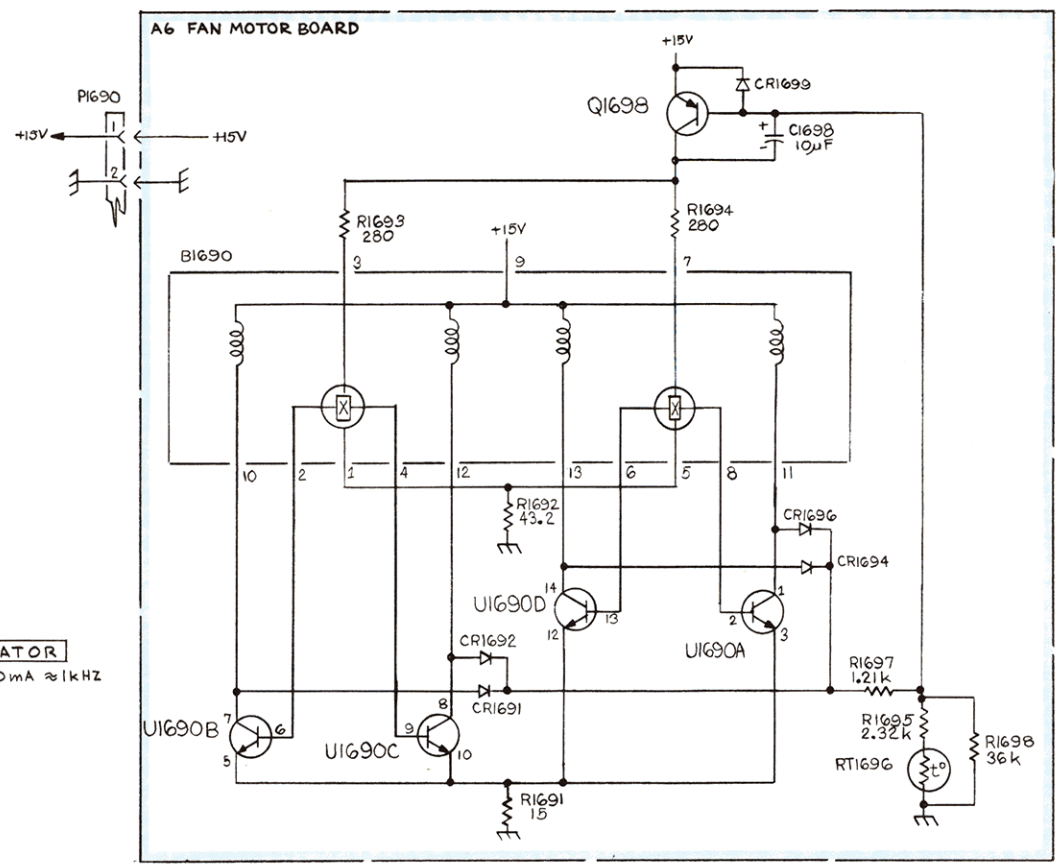
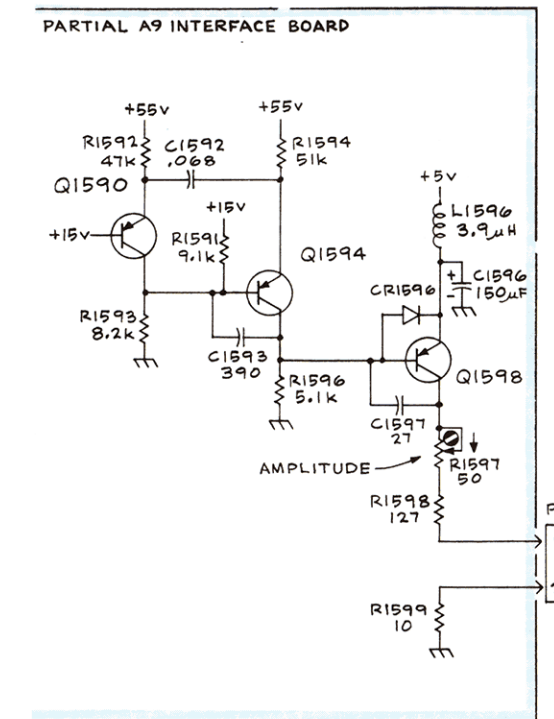

Fig. 7-20. A11 Trigger View Amplifier circuit board.

+



SEE PARTS LIST FOR EARLIER VALUES AND SERIAL NUMBER RANGES OF PARTS MARKED WITH BLUE OUTLINE.

+

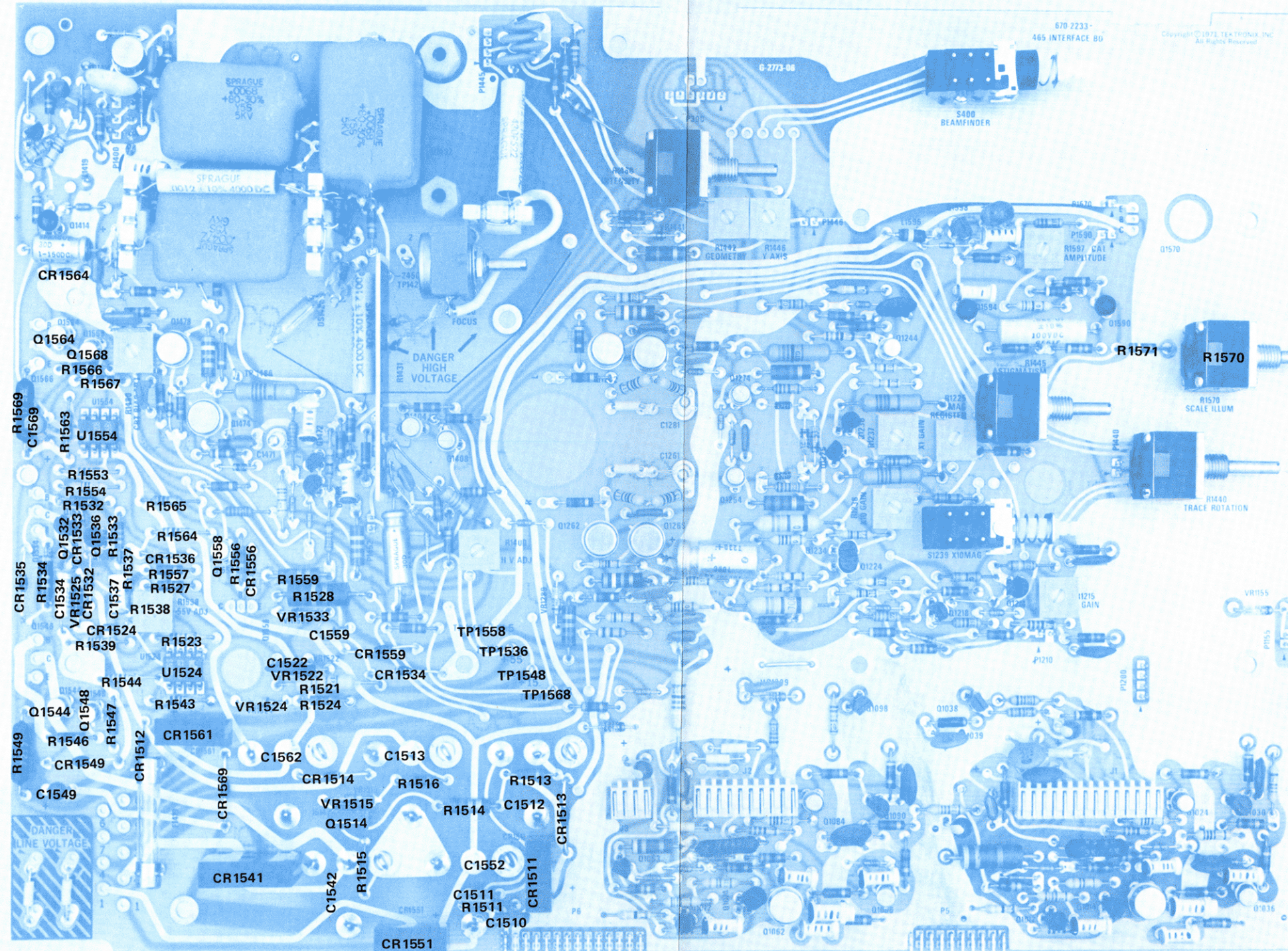
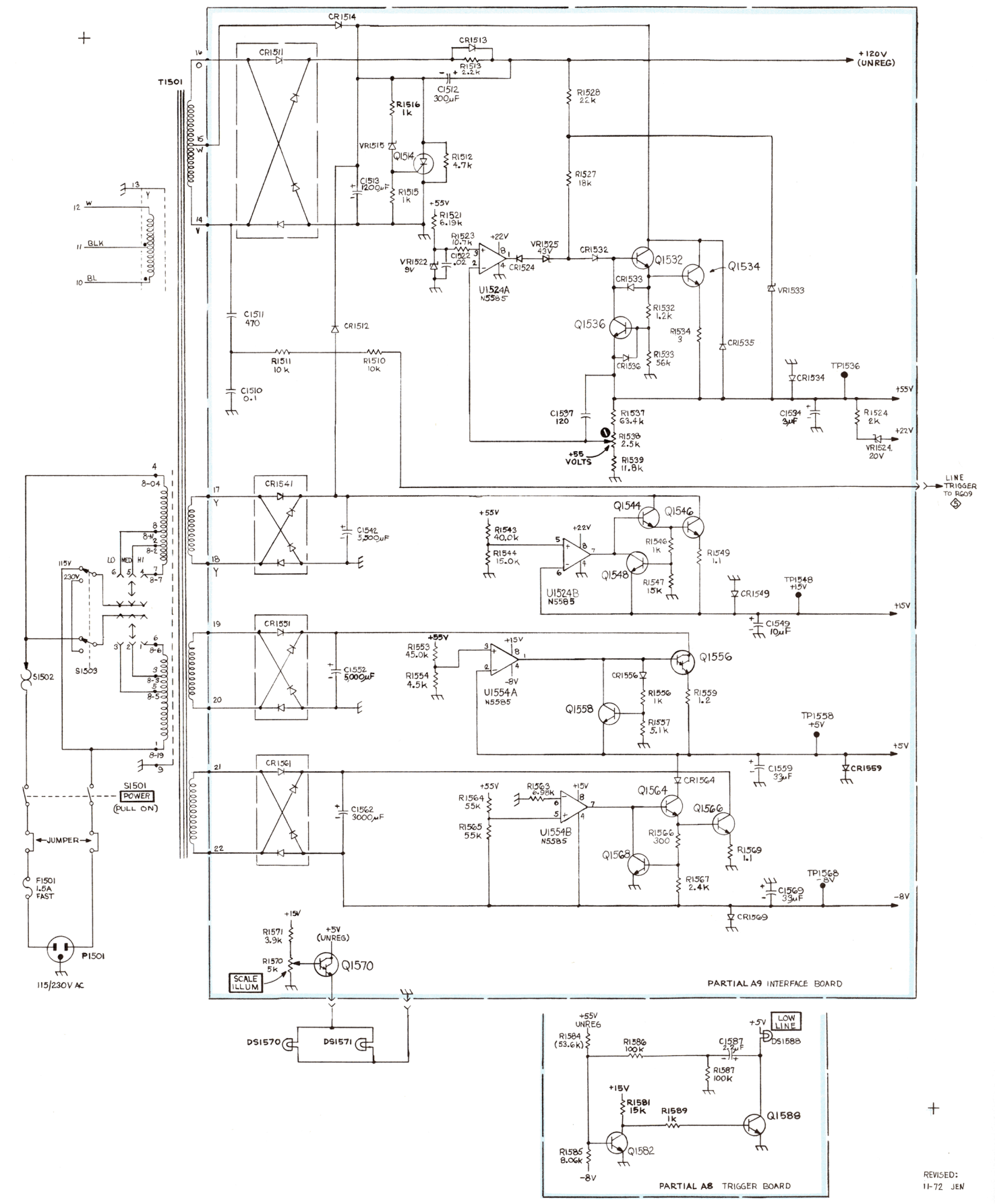

Fig. 7-21. P/O A9 Interface circuit board.



465 OSCILLOSCOPE

(A)

POWER SUPPLY

MECHANICAL PARTS LIST

Replacement parts should be ordered from the Tektronix Field Office or Representative in your area. Changes to Tektronix products give you the benefit of improved circuits and components. Please include the instrument type number and serial number with each order for parts or service.

ABBREVIATIONS

| | | | | | |
|--------|----------------------|------|------------------|-----|------------------|
| BHB | binding head brass | h | height or high | OHB | oval head brass |
| BHS | binding head steel | hex. | hexagonal | OHS | oval head steel |
| CRT | cathode-ray tube | HHB | hex head brass | PHB | pan head brass |
| csk | countersunk | HHS | hex head steel | PHS | pan head steel |
| DE | double end | HSB | hex socket brass | RHS | round head steel |
| FHB | flat head brass | HSS | hex socket steel | SE | single end |
| FHS | flat head steel | ID | inside diameter | THB | truss head brass |
| Fil HB | fillister head brass | lg | length or long | THS | truss head steel |
| Fil HS | fillister head steel | OD | outside diameter | w | wide or width |

FIGURE 1 FRONT & REAR

| Fig. & Index No. | Tektronix Part No. | Serial/Model No. | | Q † y | Description |
|------------------------|-----------------------|------------------|------|-------------|--|
| | | Eff | Disc | | |
| 1-1 | 200-1411-00 | | | 1 | BEZEL |
| -2 | 213-0313-00 | | | 4 | bezel includes: THUMBSCREW, 4-40 x 0.45 inch, knurled |
| -3 | 337-1674-00 | | | 1 | SHIELD, implosion, blue |
| -4 | 366-0494-00 | | | 3 | KNOB, gray--POSITION, A TRIGGER HOLDOFF |
| | | | | - | each knob includes: |
| | 213-0153-00 | | | 1 | SETSCREW, 5-40 x 0.125 inch, HSS |
| -5 | 358-0378-01 | | | 14 | BUSHING, sleeve |
| -6 | 358-0216-00 | | | 3 | GROMMET, gray, plastic |
| -7 | 366-1031-02 | | | 2 | KNOB, red--VAR |
| | | | | - | each knob includes: |
| | 213-0153-00 | | | 1 | SETSCREW, 5-40 x 0.125 inch, HSS |
| -8 | 366-1426-00 | | | 2 | KNOB, gray--VOLTS/DIVISION |
| | | | | - | each knob includes: |
| | 213-0153-00 | | | 2 | SETSCREW, 5-40 x 0.125 inch, HSS |
| -9 | 366-0215-02 | | | 2 | KNOB, lever switch |
| -10 | 366-1402-31 | | | 1 | PUSHBUTTON--INVERT |
| -11 | 366-1402-32 | | | 1 | PUSHBUTTON--BEAM FIND |
| -12 | 378-0803-01 | | | 2 | LENS, indicator light |
| -13 | 366-1257-20 | | | 1 | PUSHBUTTON--CH 2 |
| -14 | 366-1402-37 | | | 1 | PUSHBUTTON--CHOP |
| -15 | 366-1257-16 | | | 1 | PUSHBUTTON--ADD |
| -16 | 366-1402-36 | | | 1 | PUSHBUTTON--ALT |
| -17 | 366-1257-19 | | | 1 | PUSHBUTTON--CH 1 |
| -18 | 426-0681-00 | | | 16 | FRAME, pushbutton |
| -19 | 366-1023-01 | | | 3 | KNOB, gray--INTENSITY-FOCUS-SCALE ILLUM |
| | | | | - | each knob includes: |
| | 213-0153-00 | | | 1 | SETSCREW, 5-40 x 0.125 inch, HSS |
| -20 | 366-1346-02 | | | 1 | KNOB, red--VAR |
| | | | | - | knob includes: |
| | 213-0153-00 | | | 1 | SETSCREW, 5-40 x 0.125 inch, HSS |

FIGURE 1 FRONT & REAR (cont)

| Fig. & Index No. | Tektronix Part No. | Serial/Model No. Eff | Disc | Q | | | | | Description | |
|------------------|------------------------|----------------------|------|----|---|---|---|---|-------------|--|
| | | | | y | 1 | 2 | 3 | 4 | | 5 |
| 1-21 | 366-1219-00 | | | 1 | | | | | | 1 KNOB, interlocking--DELY'D SWEEP |
| | - - - - - | | | - | | | | | | knob includes: |
| | 213-0153-00 | | | 2 | | | | | | SETSCREW, 5-40 x 0.125 inch, HSS |
| -22 | 354-0442-00 | | | 1 | | | | | | RING, knob skirt |
| | - - - - - | | | - | | | | | | ring includes: |
| | 213-0153-00 | | | 1 | | | | | | SETSCREW, 5-40 x 0.125 inch, HSS |
| -23 | 401-0080-00 | | | 1 | | | | | | BEARING, knob skirt |
| -24 | 366-1327-00 | | | 1 | | | | | | KNOB, gray--FINE |
| | - - - - - | | | - | | | | | | knob includes: |
| | 213-0153-00 | | | 1 | | | | | | SETSCREW, 5-40 x 0.125 inch, HSS |
| -25 | 366-1280-00 | | | 3 | | | | | | KNOB, gray--HORIZ POSITION, LEVEL |
| | - - - - - | | | - | | | | | | each knob includes: |
| | 213-0153-00 | | | 1 | | | | | | SETSCREW, 5-40 x 0.125 inch, HSS |
| -26 | 366-1402-33 | | | 1 | | | | | | PUSHBUTTON--X10 |
| -27 | 366-1402-35 | | | 1 | | | | | | PUSHBUTTON--B DLY'D |
| -28 | 366-1402-44 | | | 1 | | | | | | PUSHBUTTON--A INTEN |
| -29 | 366-1257-29 | | | 1 | | | | | | PUSHBUTTON--SINGLE SWP |
| -30 | 366-1402-34 | | | 1 | | | | | | PUSHBUTTON--A |
| -31 | 366-1402-38 | | | 1 | | | | | | PUSHBUTTON--AUTO |
| -32 | 366-1402-39 | | | 1 | | | | | | PUSHBUTTON--NORM |
| -33 | 366-1402-29 | | | 1 | | | | | | PUSHBUTTON--MIX |
| -34 | 378-0803-00 | | | 5 | | | | | | LENS, indicator light |
| -35 | 366-1278-00 | | | 2 | | | | | | KNOB, gray--SLOPE |
| | - - - - - | | | - | | | | | | each knob includes: |
| | 213-0153-00 | | | 1 | | | | | | SETSCREW, 5-40 x 0.125 inch, HSS |
| -36 | - - - - - ¹ | | | 1 | | | | | | RESISTOR, variable, w/hardware |
| -37 | 331-0328-00 | | | 1 | | | | | | DIAL, control--DELAY TIME POSITION |
| | - - - - - | | | - | | | | | | dial includes: |
| | 213-0048-00 | | | 1 | | | | | | SETSCREW, 4-40 x 0.125 inch, HSS |
| -38 | 378-0635-00 | | | 4 | | | | | | LENS, indicator light |
| -39 | 333-1635-00 | | | 1 | | | | | | PANEL, front |
| -40 | - - - - - ¹ | | | 4 | | | | | | RESISTOR, variable |
| | | | | | | | | | | (ATTACHING PARTS FOR EACH) |
| -41 | 210-0583-00 | | | 1 | | | | | | NUT, hex., 0.25-32 x 0.312 inch |
| -42 | 210-0940-00 | | | 1 | | | | | | WASHER, flat, 0.25 ID x 0.375 inch OD |
| | | | | | | | | | | - - - * - - - - |
| -43 | 131-0955-00 | | | 2 | | | | | | CONNECTOR, electrical, female, BNC, w/hardware |
| -44 | 119-0373-00 | | | 1 | | | | | | CURRENT LOOP |
| | | | | | | | | | | (ATTACHING PARTS) |
| -45 | 210-0586-00 | | | 2 | | | | | | NUT, keps, 4-40 x 0.25 inch |
| -46 | 210-0994-00 | | | 2 | | | | | | WASHER, flat, 0.125 ID x 0.25 inch OD |
| -47 | 210-0849-00 | | | 2 | | | | | | WASHER, fiber, shouldered, 0.11 ID x 0.187 inch OD |
| -48 | 361-0059-01 | | | 1 | | | | | | SPACER, current loop |
| -49 | 210-0593-00 | | | 2 | | | | | | NUT, current loop |
| | | | | | | | | | | - - - * - - - - |
| -50 | 386-2330-00 | | | 1 | | | | | | SUBPANEL, front |
| | | | | | | | | | | (ATTACHING PARTS) |
| -51 | 213-0107-00 | | | 11 | | | | | | SCREW, thread forming, 4-40 x 0.25 inch, 100 deg. |
| | - - - - - | | | - | | | | | | csk, FHS |

¹See Electrical Parts List for part number.

FIGURE 1 FRONT & REAR (cont)

| Fig. & Index No. | Tektronix Part No. | Serial/Model No. | | Q | Description |
|------------------|--------------------|------------------|------|----|---|
| | | Eff | Disc | | |
| 1-52 | 352-0340-00 | | | 2 | HOLDER, lamps (ATTACHING PARTS FOR EACH) |
| -53 | 211-0001-00 | | | 1 | SCREW, 2-56 x 0.25 inch, PHS - - - * - - - |
| -54 | 348-0276-00 | | | ft | SHIELDING GASKET, electrical, 2.75 feet |
| -55 | 426-0926-01 | | | 1 | FRAME, cabinet, front (ATTACHING PARTS) |
| -56 | 213-0183-00 | | | 4 | SCREW, thread forming, 6-32 x 0.50 inch, PHS - - - * - - - |
| -57 | 386-2340-00 | | | 4 | SUPPORT, CRT, front |
| -58 | - - - - - 1 | | | 1 | CIRCUIT BOARD ASSEMBLY--GRATICULE ILLUM A10 circuit board assembly includes: |
| -59 | 378-0728-00 | | | 1 | REFLECTOR, light |
| -60 | 352-0329-00 | | | 1 | HOLDER, lamps |
| -61 | 175-0825-00 | | | ft | WIRE, electrical, 2 wire ribbon, 5.75 inches |
| -62 | 131-0707-00 | | | 2 | CONNECTOR, terminal |
| -63 | 352-0169-02 | | | 1 | HOLDER, terminal connector, 2 wire (red) |
| -64 | 441-1084-00 | | | 1 | CHASSIS, main |
| -65 | - - - - - 1 | | | 1 | COIL, trace rotation |
| -66 | 344-0250-00 | | | 1 | CLIP, electrical (ATTACHING PARTS) |
| -67 | 211-0008-00 | | | 1 | SCREW, 4-40 x 0.25 inch, PHS |
| -68 | 210-0586-00 | | | 1 | NUT, keps, 4-40 x 0.25 inch - - - * - - - |
| -69 | 348-0253-00 | | | 1 | GROMMET, plastic, 1.145 inches ID |
| -70 | 348-0115-00 | | | 1 | GROMMET, plastic, u-shape |
| -71 | 348-0063-00 | | | 3 | GROMMET, plastic, 0.50 inch OD |
| -72 | 348-0056-00 | | | 4 | GROMMET, plastic, 0.375 inch ID |
| -73 | - - - - - 1 | | | 1 | DELAY LINE |
| -74 | 407-1137-00 | | | 1 | BRACKET, delay line (ATTACHING PARTS) |
| -75 | 210-0457-00 | | | 1 | NUT, keps, 6-32 x 0.312 inch - - - * - - - |
| -76 | - - - - - 1 | | | 3 | TRANSISTOR (ATTACHING PARTS FOR EACH) |
| -77 | 211-0012-00 | | | 1 | SCREW, 4-40 x 0.375 inch, PHS |
| -78 | 210-0071-00 | | | 1 | WASHER, spring tension |
| -79 | 342-0163-00 | | | 1 | INSULATOR, transistor - - - * - - - |
| -80 | - - - - - 1 | | | 1 | TRANSFORMER transformer includes: |
| -81 | 407-1066-00 | | | 1 | BRACKET, transformer |
| -82 | 212-0522-00 | | | 4 | SCREW, 10-32 x 2.50 inches, HHS |
| -83 | 210-0812-00 | | | 4 | WASHER, fiber, #10 |
| -84 | 166-0457-00 | | | 4 | TUBE, insulating, 1.875 inches long |
| -85 | 200-1544-01 | | | 1 | COVER, transformer |
| | 210-0056-00 | | | 4 | WASHER, lock, split, #10 (not shown) |
| -86 | 220-0561-00 | | | 4 | NUT, hex., 10-32 x 0.25 inch (ATTACHING PARTS) |
| -87 | 211-0538-00 | | | 2 | SCREW, 6-32 x 0.312 inch, 100 deg. csk, PHS |
| -88 | 210-0457-00 | | | 4 | NUT, keps, 6-32 x 0.312 inch |

¹ See Electrical Parts List for part number.

FIGURE 1 FRONT & REAR (cont)

| Fig. & Index No. | Tektronix Part No. | Serial/Model No. Eff | Disc | Q | | | | | Description | |
|------------------------|------------------------|-------------------------|------|--------|---|---|---|---|-------------|--|
| | | | | † y | 1 | 2 | 3 | 4 | | 5 |
| 1-89 | 337-1763-00 | | | 1 | | | | | | SHIELD, electrical, transformer |
| -90 | 348-0063-00 | | | 1 | | | | | | GROMMET, plastic, 0.50 inch OD |
| -91 | 260-0638-00 | | | 1 | | | | | | SWITCH, thermostatic (ATTACHING PARTS) |
| -92 | 213-0044-00 | | | 2 | | | | | | SCREW, thread forming, 5-32 x 0.188 inch, PHS - - - * - - - |
| -93 | 210-0201-00 | | | 1 | | | | | | LUG, solder, SE #4 (ATTACHING PARTS) |
| -94 | 211-0038-00 | | | 1 | | | | | | SCREW, 4-40 x 0.312 inch, 100 deg. csk, FHS |
| -95 | 210-0586-00 | | | 1 | | | | | | NUT, keps, 4-40 x 0.25 inch - - - * - - - |
| -96 | 129-0388-00 | | | 2 | | | | | | POST, hex., 1.673 inches long |
| -97 | 337-1688-00 | | | 1 | | | | | | SHIELD, electrical, high voltage (ATTACHING PARTS) |
| -98 | 211-0065-00 | | | 3 | | | | | | SCREW, 4-40 x 0.188 inch, PHS - - - * - - - |
| -99 | - - - - - ¹ | | | 1 | | | | | | CIRCUIT BOARD ASSEMBLY--FAN MOTOR A6 - circuit board assembly includes: |
| -100 | 136-0269-00 | | | 1 | | | | | | SOCKET, integrated circuit, 14 pin |
| -101 | 131-0608-00 | | | 2 | | | | | | TERMINAL, pin, 0.365 inch long |
| -102 | 136-0252-04 | | | 3 | | | | | | SOCKET, pin connector |
| -103 | 426-0781-00 | | | 1 | | | | | | MOUNT, motor (ATTACHING PARTS) |
| -104 | 213-0088-00 | | | 2 | | | | | | SCREW, thread forming, 4-40 x 0.25 inch, PHS - - - * - - - |
| -105 | 337-1762-00 | | | 1 | | | | | | SHIELD, electrical, fan motor |
| -106 | 426-0781-00 | | | 1 | | | | | | MOUNT, motor (ATTACHING PARTS) |
| -107 | 213-0088-00 | | | 2 | | | | | | SCREW, thread forming, 4-40 x 0.25 inch, PHS - - - * - - - |
| -108 | 407-1153-00 | | | 1 | | | | | | BRACKET, transistor (ATTACHING PARTS) |
| -109 | 210-0586-00 | | | 2 | | | | | | NUT, keps, 4-40 x 0.25 inch - - - * - - - |
| -110 | - - - - - | | | 1 | | | | | | TRANSISTOR (ATTACHING PARTS) |
| -111 | 211-0012-00 | | | 2 | | | | | | SCREW, 4-40 x 0.375 inch, PHS |
| -112 | 210-0205-00 | | | 1 | | | | | | LUG, solder, SE #8 |
| -113 | 358-0214-00 | | | 2 | | | | | | BUSHING, insulator |
| -114 | 214-1610-00 | | | 1 | | | | | | HEATSINK, transistor - - - * - - - |
| -115 | 369-0031-00 | | | 1 | | | | | | IMPELLER, fan, w/setscrew |
| -116 | 348-0349-00 | | | ft | | | | | | SHIELDING GASKET, electrical, 2.75 feet |
| -117 | 426-0970-00 | | | 1 | | | | | | FRAME SECTION, cabinet rear |
| -118 | 348-0339-00 | | | 4 | | | | | | FOOT, cabinet, w/cord wrap (ATTACHING PARTS FOR EACH) |
| -119 | 212-0020-00 | | | 1 | | | | | | SCREW, 8-32 x 1.0 inch, PHS |

¹See Electrical Parts List for part number.

FIGURE 1 FRONT & REAR (cont)

| Fig. & Index No. | Tektronix Part No. | Serial/Model No. | | Q f y | Description |
|------------------------|-----------------------|------------------|---------|-------------|---|
| | | Eff | Disc | | |
| 1-120 | 386-2332-00 | | | 1 | PANEL, rear (ATTACHING PARTS) |
| -121 | 211-0105-00 | | | 1 | SCREW, 4-40 x 0.188 inch, 100 deg. csk, FHS - - - * - - - |
| -122 | 204-0549-01 | | | 1 | BODY, line voltage selector (ATTACHING PARTS) |
| -123 | 210-0407-00 | | | 2 | NUT, hex., 6-32 x 0.25 inch |
| -124 | 210-0006-00 | | | 2 | WASHER, lock, split, 0.145 ID x 0.253 inch OD - - - * - - - |
| -125 | 200-1445-01 | | | 1 | COVER, line voltage selector |
| | - - - - - | | | - | cover includes: |
| | 352-0102-00 | | | 1 | HOLDER, fuse, plastic (not shown) (ATTACHING PARTS) |
| | 213-0034-00 | | | 2 | SCREW, thread cutting, 4-40 x 0.312 inch, PHS (not shown) - - - * - - - |
| | 161-0090-00 | B010100 | B010409 | 1 | CABLE ASSEMBLY, power |
| -126 | 161-0033-07 | B010410 | | 1 | CABLE ASSEMBLY, power |
| -127 | 358-0372-00 | | | 1 | BUSHING, strain relief, bottom |
| -128 | 200-1004-00 | | | 1 | CABLE NIPPLE |
| -129 | 358-0371-00 | | | 1 | BUSHING, strain relief, top |
| -130 | 200-1414-01 | | | 1 | COVER, rear (ATTACHING PARTS) |
| -131 | 211-0101-00 | | | 2 | SCREW, 4-40 x 0.25 inch, 100 deg. csk, FHS |
| -132 | 211-0516-00 | | | 2 | SCREW, 6-32 x 0.875 inch, PHS - - - * - - - |
| -133 | 386-2408-00 | | | 1 | PLATE, connector mounting |
| -134 | 131-0955-00 | | | 4 | CONNECTOR, electrical, female, BNC, w/hardware (ATTACHING PARTS FOR EACH) |
| -135 | 210-0255-00 | | | 1 | TERMINAL, lug, solder, 0.391 inch ID |

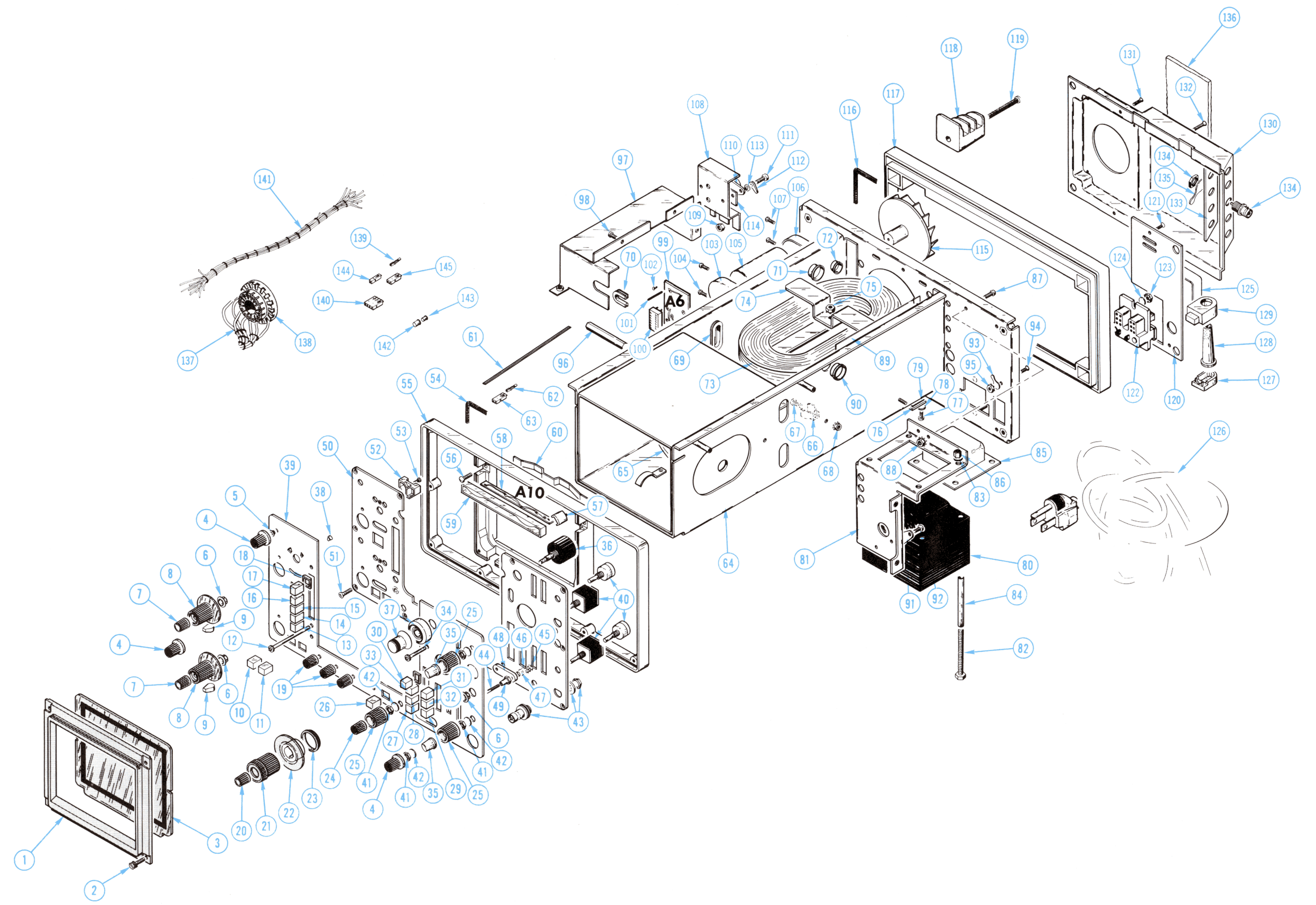

+6

+

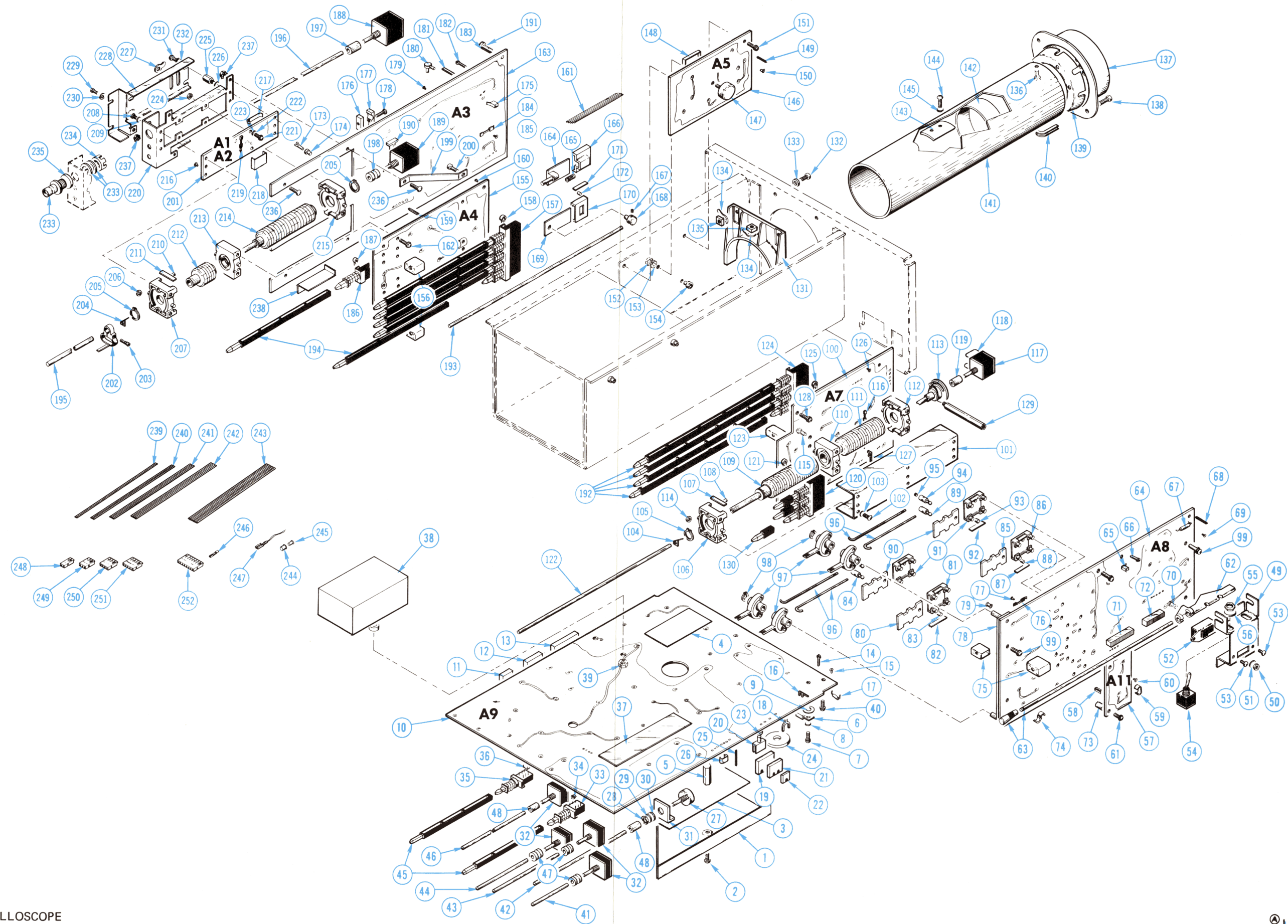

+

FIGURE 2 CIRCUIT BOARDS

| Fig. & Index No. | Tektronix Part No. | Serial/Model No. | | Q † y | Description |
|------------------------|------------------------|------------------|---------|-------------|--|
| | | Eff | Disc | | |
| 2-1 | 337-1711-01 | | | 1 | SHIELD, electrical, high voltage (ATTACHING PARTS) |
| -2 | 211-0008-00 | B010100 | B039999 | 4 | SCREW, 4-40 x 0.25 inch, PHS |
| | 211-0008-00 | B040000 | | 3 | SCREW, 4-40 x 0.25 inch, PHS |
| | 211-0110-00 | B040000 | | 1 | SCREW, 4-40 x 0.312 inch, PHS |
| | 210-1001-00 | XB040000 | | 1 | WASHER, flat, 0.119 inch ID |
| | 131-1428-00 | XB040000 | | 1 | CLIP, ground |
| | | | | | - - - * - - - |
| -3 | 342-0175-00 | | | 1 | INSULATOR, film, 3.65 x 4.70 inches |
| -4 | 342-0159-00 | | | 1 | INSULATOR, film |
| -5 | 129-0413-00 | | | 4 | POST, hex., 0.62 inch long |
| -6 | - - - - - | | | 2 | TRANSISTOR (ATTACHING PARTS FOR EACH) |
| -7 | 211-0180-00 | | | 1 | SCREW, sems, 2-56 x 0.25 inch, PHB |
| -8 | 210-1156-00 | | | 1 | WASHER, shouldered, plastic, 0.09 ID x 0.121 inch, OD |
| -9 | 342-0166-00 | | | 1 | INSULATOR, transistor - - - * - - - |
| -10 | - - - - - ¹ | | | 1 | CIRCUIT BOARD ASSEMBLY--INTERFACE A9 circuit board assembly includes: |
| -11 | 136-0499-04 | | | 1 | SOCKET, circuit board, 4 contact |
| -12 | 136-0499-10 | | | 1 | SOCKET, circuit board, 10 contact |
| -13 | 136-0499-14 | | | 1 | SOCKET, circuit board, 14 contact |
| -14 | 214-0579-00 | | | 6 | PIN, test point |
| -15 | 136-0252-04 | | | 162 | SOCKET, pin connector |
| -16 | 131-1261-00 | | | 24 | CONTACT, electrical, f-shape |
| -17 | 131-0566-00 | | | 7 | LINK, terminal connecting |
| -18 | 344-0154-00 | | | 2 | CLIP, electrical, fuse |
| -19 | 124-0092-00 | | | 2 | STRIP, ceramic, 3 notch each strip includes: |
| | - - - - - | | | - | STUD, plastic |
| -20 | 355-0046-00 | | | 1 | STRIP, ceramic, 2 notch strip includes: |
| -21 | 124-0119-00 | | | 1 | STUD, plastic |
| | - - - - - | | | - | STRIP, ceramic, 1 notch strip includes: |
| | 355-0046-00 | | | 1 | STUD, plastic |
| -22 | 124-0118-00 | | | 10 | BUSHING, insulator |
| -23 | 358-0214-00 | | | 1 | WASHER, insulating, rubber, 0.875 ID |
| -24 | 210-0966-00 | | | 33 | TERMINAL, pin, 0.365 inch long |
| -25 | 131-0608-00 | | | 1 | HEATSINK, transistor |
| -26 | 214-0973-00 | | | 1 | RESISTOR, variable (ATTACHING PARTS) |
| -27 | - - - - - ¹ | | | 1 | NUT, hex., 0.25-32 x 0.312 inch |
| -28 | 210-0583-00 | | | 1 | WASHER, flat, 0.25 ID x 0.375 inch OD |
| -29 | 210-0940-00 | | | 1 | WASHER, lock, 0.261 ID x 0.40 inch OD |
| -30 | 210-0046-00 | | | | - - - * - - - |
| -31 | 386-2433-00 | | | 1 | SUPPORT, resistor |
| -32 | - - - - - ¹ | | | 4 | RESISTOR, variable |
| -33 | 260-1208-00 | | | 1 | SWITCH, push--X10 MAG (ATTACHING PARTS) |
| -34 | 361-0384-00 | | | 2 | SPACER, pushbutton switch, 0.133 inch long |

¹ See Electrical Parts List for part number.

FIGURE 2 CIRCUIT BOARDS (cont)

| Fig. & Index No. | Tektronix Part No. | Serial/Model No. Eff Disc | Q | | | | | Description | |
|------------------------|--------------------------|------------------------------|----|---|---|---|---|-------------|---|
| | | | t | y | 1 | 2 | 3 | | 4 |
| 2-35 | 260-1421-00 | | 1 | | | | | | SWITCH, push--BEAM FIND (ATTACHING PARTS) |
| -36 | 361-0385-00 | | 2 | | | | | | SPACER, pushbutton switch, 0.164 inch long - - - * - - - |
| -37 | 337-1759-00 ₁ | | 1 | | | | | | SHIELD, electrical |
| -38 | - - - - - | | 1 | | | | | | MULTIPLIER (ATTACHING PARTS) |
| -39 | 220-0661-00 | | 2 | | | | | | NUT, self-locking, hex., 8-32 x 0.344 inch (ATTACHING PARTS) |
| -40 | 211-0116-00 | | 8 | | | | | | SCREW, sems, 4-40 x 0.312 inch, PHB - - - * - - - |
| -41 | 384-1174-00 | | 1 | | | | | | SHAFT, extension, 1.80 inches long |
| -42 | 384-1179-00 | | 1 | | | | | | SHAFT, extension, 9.312 inches long |
| -43 | 384-1187-00 | | 1 | | | | | | SHAFT, extension, 3.4 inches long |
| -44 | 384-1173-00 | | 1 | | | | | | SHAFT, extension, 1.90 inches long |
| -45 | 384-1101-00 | | 2 | | | | | | SHAFT, extension, 4.14 inches long |
| -46 | 384-1149-00 | | 1 | | | | | | SHAFT, extension, 7 inches long |
| -47 | 376-0051-00 | | 3 | | | | | | COUPLING, flexible |
| | - - - - - | | - | | | | | | each coupling includes: |
| | 213-0022-00 | | 4 | | | | | | SETSCREW, 4-40 x 0.188 inch, HSS |
| -48 | 376-0029-00 | | 2 | | | | | | COUPLING, shaft, rigid |
| | - - - - - | | - | | | | | | each coupling includes: |
| | 213-0022-00 | | 2 | | | | | | SETSCREW, 4-40 x 0.188 inch, HSS |
| -49 | 407-1133-00 | | 1 | | | | | | BRACKET, power switch (ATTACHING PARTS) |
| -50 | 210-0406-00 | | 2 | | | | | | NUT, hex., 4-40 x 0.188 inch |
| -51 | 210-0994-00 | | 2 | | | | | | WASHER, flat, 0.125 ID x 0.25 inch OD - - - * - - - |
| | 200-1526-00 | XB030000 | 1 | | | | | | COVER, switch hole (not shown) |
| -52 | 260-1300-01 | | 1 | | | | | | SWITCH, slide--LINE (ATTACHING PARTS) |
| -53 | 211-0007-00 | | 2 | | | | | | SCREW, 4-40 x 0.188 inch, PHS - - - * - - - |
| -54 | 260-0834-00 | | 1 | | | | | | SWITCH, toggle--POWER (ATTACHING PARTS) |
| -55 | 210-0562-00 | | 1 | | | | | | NUT, hex., 0.25-40 x 0.312 inch |
| -56 | 210-0046-00 | | 1 | | | | | | WASHER, lock, internal, 0.261 ID x 0.40 inch OD - - - * - - - |
| -57 | - - - - - ₁ | | 1 | | | | | | CIRCUIT BOARD ASSEMBLY--TRIG VIEW All - circuit board assembly includes: |
| -58 | 136-0327-01 | | 4 | | | | | | SOCKET, pin terminal, 0.067 inch diameter |
| -59 | 214-0973-00 | | 1 | | | | | | HEATSINK, transistor |
| -60 | 136-0252-04 | | 12 | | | | | | SOCKET, pin connector, 0.181 inch long (ATTACHING PARTS) |
| -61 | 211-0116-00 | | 1 | | | | | | SCREW, sems, 4-40 x 0.312 inch, PHB |

¹See Electrical Parts List for part number.

FIGURE 2 CIRCUIT BOARDS (cont)

| Fig. & Index No. | Tektronix Part No. | Serial/Model No. | | Q † y | Description |
|------------------------|--------------------------|------------------|------|-------------|---|
| | | Eff | Disc | | |
| 2-62 | 214-1756-00 | | | 1 | ACTUATOR, power switch |
| -63 | 384-1159-00 | | | 1 | SHAFT, extension |
| -64 | - - - - - | 1 | | 1 | CIRCUIT BOARD ASSEMBLY--TRIG GEN & SWP LOGIC A8 |
| | - - - - - | | | - | circuit board assembly includes: |
| -65 | 131-1003-00 | | | 6 | RECEPTACLE, coaxial cable |
| -66 | 214-0579-00 | | | 1 | TERMINAL, test point |
| -67 | 131-0566-00 | | | 1 | LINK, terminal connecting |
| -68 | 131-0590-00 | | | 4 | TERMINAL, pin, 0.71 inch long |
| | 131-0608-00 | | | 12 | TERMINAL, pin, 0.365 inch long |
| -69 | 136-0252-04 | | | 148 | SOCKET, connector pin, 0.181 inch long |
| -70 | 355-0175-00 | | | 2 | STUD, press mount, 4-40 x 0.35 inch long |
| -71 | 136-0499-14 | | | 1 | SOCKET, circuit board, 14 contact |
| -72 | 136-0499-10 | | | 1 | SOCKET, circuit board, 10 contact |
| -73 | 129-0411-00 | | | 1 | POST, hex., 0.315 inch long |
| -74 | 200-1167-00 | | | 2 | COVER, transistor |
| -75 | 352-0331-00 | | | 3 | HOLDER, lamp |
| -76 | 131-1031-00 | | | 23 | CONTACT ASSEMBLY, top (ATTACHING PARTS FOR EACH) |
| -77 | 210-0779-00 | | | 1 | RIVET, tubular - - - * - - - |
| -78 | 386-2376-00 | | | 1 | PLATE, lever mounting |
| -79 | 210-0657-01 | | | 2 | EYELET |
| | 105-0401-00 | | | 1 | ACTUATOR ASSEMBLY, slide switch--B SOURCE |
| | - - - - - | | | - | actuator assembly includes: |
| -80 | 105-0417-00 | | | 1 | ACTUATOR, switch, slide |
| -81 | 351-0355-00 | | | 1 | GUIDE, switch, slide |
| -82 | 214-1126-00 ² | | | - | SPRING, flat, gold |
| | 214-1126-01 ² | | | - | SPRING, flat, green |
| | 214-1126-02 ² | | | - | SPRING, flat, red |
| -83 | 214-1127-00 | | | 2 | ROLLER, detent |
| -84 | 376-0142-00 | | | 1 | COUPLER, slide to shaft |
| | 213-0048-00 | | | 1 | SETSCREW, 4-40 x 0.125 inch, HSS (not shown) |
| | 105-0400-00 | | | 1 | ACTUATOR ASSEMBLY, slide switch--A SOURCE |
| | - - - - - | | | - | actuator assembly includes: |
| -85 | 105-0418-00 | | | 1 | ACTUATOR, switch, slide |
| -86 | 351-0355-00 | | | 1 | GUIDE, switch, slide |
| -87 | 214-1126-00 ² | | | - | SPRING, flat, gold |
| | 214-1126-01 ² | | | - | SPRING, flat, green |
| | 214-1126-02 ² | | | - | SPRING, flat, red |
| -88 | 214-1127-00 | | | 2 | ROLLER, detent |
| -89 | 376-0142-00 | | | 1 | COUPLER, slide to shaft |
| | 213-0048-00 | | | 1 | SETSCREW, 4-40 x 0.125 inch, HSS |
| | 105-0399-00 | | | 2 | ACTUATOR ASSEMBLY, slide switch--COUPLING |
| | - - - - - | | | - | each actuator assembly includes: |
| -90 | 105-0419-00 | | | 1 | ACTUATOR, switch, slide |
| -91 | 351-0355-00 | | | 1 | GUIDE, switch, slide |
| -92 | 214-1126-00 ² | | | - | SPRING, flat, gold |
| | 214-1126-01 ² | | | - | SPRING, flat, green |
| | 214-1126-02 ² | | | - | SPRING, flat, red |
| -93 | 214-1127-00 | | | 2 | ROLLER, detent |

¹See Electrical Parts List for part number.

²Replace only with part bearing the same color code as the original part in your instrument.

FIGURE 2 CIRCUIT BOARDS (cont)

| Fig. & Index No. | Tektronix Part No. | Serial/Model No. | | Q t y | Description |
|------------------------|--------------------------|------------------|------|-------------|---|
| | | Eff | Disc | | |
| 2-94 | 376-0142-00 | | | 1 | COUPLER, slide to shaft |
| -95 | 213-0048-00 | | | 1 | SETSCREW, 4-40 x 0.125 inch, HSS |
| -96 | 384-1160-00 | | | 4 | SHAFT, extension, lever switch |
| -97 | 214-1770-00 | | | 4 | LEVER, slide switch (ATTACHING PARTS) |
| -98 | 354-0165-00 | | | 2 | RING, retaining (ATTACHING PARTS) |
| -99 | 211-0116-00 | | | 3 | SCREW, sems, 4-40 x 0.312 inch, PHB - - - * - - - |
| -100 | - - - - - ¹ | | | 1 | CIRCUIT BOARD ASSEMBLY--TIMING A7 |
| | - - - - - | | | - | circuit board assembly includes: |
| | 105-0366-00 | | | 1 | ACTUATOR ASSEMBLY, cam switch--TIME/CM |
| | - - - - - | | | - | actuator assembly includes: |
| -101 | 200-1419-00 | | | 1 | COVER, cam switch (ATTACHING PARTS) |
| -102 | 211-0008-00 | | | 6 | SCREW, 4-40 x 0.25 inch, PHS |
| -103 | 210-0004-00 | | | 6 | WASHER, lock, internal, 0.12 ID x 0.26 inch OD |
| | 210-0406-00 | | | 5 | NUT, hex., 4-40 x 0.188 inch (not shown) - - - * - - - |
| -104 | 131-0963-00 | | | 2 | CONTACT, electrical, grounding |
| -105 | 354-0391-00 | | | 2 | RING, retaining |
| -106 | 401-0081-02 | | | 1 | BEARING, cam switch, front |
| -107 | 214-1139-00 ² | | | - | SPRING, flat, gold |
| | 214-1139-02 ² | | | - | SPRING, flat, green |
| | 214-1139-03 ² | | | - | SPRING, flat, red |
| -108 | 214-1127-00 | | | 4 | ROLLER, detent |
| -109 | 105-0365-00 | | | 1 | ACTUATOR, cam switch, front |
| -110 | 401-0115-00 | | | 1 | BEARING, cam switch, center |
| -111 | 105-0364-00 | | | 1 | ACTUATOR, cam switch, rear |
| -112 | 401-0081-04 | | | 1 | BEARING, cam switch, front, w/insert |
| -113 | 105-0410-00 | | | 1 | STOP ASSEMBLY, cam switch |
| -114 | 210-0406-00 | | | 5 | NUT, hex., 4-40 x 0.188 inch (ATTACHING PARTS) |
| -115 | 211-0116-00 | | | 6 | SCREW, sems, 4-40 x 0.312 inch, PHB - - - * - - - |
| -116 | 131-0604-00 | | | 29 | CONTACT, electrical, spring |
| -117 | - - - - - ¹ | | | 1 | RESISTOR, variable (ATTACHING PARTS) |
| -118 | 361-0515-00 | | | 1 | SPACER, switch, plastic - - - * - - - |
| -119 | 376-0039-00 | | | 1 | COUPLING, shaft |
| | - - - - - | | | - | coupling includes: |
| | 213-0075-00 | | | 2 | SETSCREW, 4-40 x 0.094 inch, HSS |
| -120 | 260-1422-00 | | | 1 | SWITCH, pushbutton--TRIG MODE (ATTACHING PARTS) |
| -121 | 361-0411-00 | | | 4 | SPACER, pushbutton switch - - - * - - - |
| -122 | 384-1068-00 | | | 1 | SHAFT, extension, 8 inches long |
| -123 | 352-0331-00 | | | 2 | HOLDER, lamp |
| -124 | 260-1423-00 | | | 1 | SWITCH, pushbutton--HORIZ DISPLAY (ATTACHING PARTS) |
| -125 | 361-0385-00 | | | 4 | SPACER, pushbutton switch |

¹See Electrical Parts List for part number.

²Replace only with part bearing the same color code as the original part in your instrument.

FIGURE 2 CIRCUIT BOARDS (cont)

| Fig. & Index No. | Tektronix Part No. | Serial/Model No. | | Q † y | Description |
|------------------------|------------------------|------------------|----------|-------------|--|
| | | Eff | Disc | | |
| 2-126 | 136-0252-04 | | | 6 | SOCKET, pin connector, 0.181 inch long |
| -127 | 131-1261-00 | | | 28 | CONTACT, electrical, f-shape (ATTACHING PARTS) |
| -128 | 211-0116-00 | | | 1 | SCREW, sems, 4-40 x 0.312 inch, PHB |
| -129 | 129-0386-00 | | | 1 | POST, hex., 1.613 inches long - - - * - - - |
| -130 | 384-1136-00 | | | 3 | SHAFT, extension, 0.95 inch long |
| -131 | 407-1128-00 | | | 1 | BRACKET, CRT shield, rear (ATTACHING PARTS) |
| -132 | 211-0507-00 | | | 2 | SCREW, 6-32 x 0.312 inch, PHS |
| -133 | 210-0803-00 | | | 2 | WASHER, flat, 0.15 ID x 0.375 inch OD |
| -134 | 210-0202-00 | | | 2 | LUG, solder, SE #6 |
| -135 | 220-0419-00 | | | 3 | NUT, square, 6-32 x 0.312 inch |
| -136 | 211-0590-00 | | | 1 | SCREW, 6-32 x 0.25 inch, PHS - - - * - - - |
| -137 | 200-1459-00 | | | 1 | COVER, CRT, rear (ATTACHING PARTS) |
| -138 | 211-0008-00 | | | 2 | SCREW, 4-40 x 0.25 inch, PHS - - - * - - - |
| -139 | 386-2246-00 | | | 1 | SUPPORT, CRT, rear |
| -140 | 348-0145-00 | | | 1 | GROMMET, u-shape |
| -141 | 337-1644-00 | | | 1 | SHIELD SECTION, CRT, neck |
| -142 | - - - - - ¹ | | | 1 | COIL, y axis |
| -143 | 343-0217-00 | | | 1 | CLAMP, coil, plastic (ATTACHING PARTS) |
| -144 | 211-0147-00 | | | 2 | SCREW, 4-40 x 0.25 inch, PHS |
| -145 | 210-0994-00 | | | 2 | WASHER, flat, 0.125 ID x 0.25 inch OD - - - * - - - |
| -146 | - - - - - ¹ | | | 1 | CIRCUIT BOARD ASSEMBLY--VERT OUTPUT A5 circuit board assembly includes: |
| | 129-0320-00 | XB040000 | | 1 | POST, press mount |
| -147 | - - - - - ¹ | B010100 | B039999X | 1 | INTEGRATED CIRCUIT |
| -148 | 407-1149-00 | B010100 | B039999X | 1 | BRACKET, integrated circuit, grounding |
| -149 | 131-0608-00 | B010100 | B039999 | 5 | TERMINAL, pin |
| | 131-0608-00 | B040000 | | 4 | TERMINAL, pin |
| -150 | 136-0252-01 | | | 2 | SOCKET, pin connector, 0.178 inch long |
| | 136-0252-04 | B010100 | B039999 | 17 | SOCKET, pin connector, 0.181 inch long |
| | 136-0252-04 | B040000 | | 31 | SOCKET, pin connector, 0.181 inch long (ATTACHING PARTS) |
| -151 | 211-0116-00 | B010100 | B039999 | 1 | SCREW, sems, 4-40 x 0.312 inch, PHB |
| | 211-0116-00 | B040000 | | 2 | SCREW, sems, 4-40 x 0.312 inch, PHB |
| -152 | 220-0456-00 | B010100 | B039999X | 1 | NUT, hex., 6-32 x 0.25 inch |
| -153 | 210-1092-00 | B010100 | B039999X | 1 | WASHER, flat, 0.147 ID x 0.312 inch OD |
| -154 | 361-0008-00 | B010100 | B039999X | 3 | SPACER, plastic |
| | 211-0130-00 | XB040000 | | 1 | SCREW, 4-40 x 0.25 inch, HSS |

¹See Electrical Parts List for part number.

FIGURE 2 CIRCUIT BOARDS (cont)

| Fig. & Index No. | Tektronix Part No. | Serial/Model No. Eff | No. Disc | Q † y | Description | 1 2 3 4 5 | | | | |
|------------------------|--------------------------|-------------------------|-------------|-------------|--|-----------|---|---|---|---|
| | | | | | | 1 | 2 | 3 | 4 | 5 |
| 2- | 644-0048-00 | | XB040000 | 1 | BRACKET ASSEMBLY, vertical output | | | | | |
| | - - - - - | | | - | bracket assembly includes: | | | | | |
| | 214-1138-00 | | XB040000 | 2 | HEATSINK, insulator | | | | | |
| | 352-0062-00 | | XB040000 | 2 | HOLDER, transistor heatsink | | | | | |
| | | | | | (ATTACHING PARTS FOR EACH) | | | | | |
| | 211-0033-00 | | XB040000 | 2 | SCREW, 4-40 x 0.312 inch, PHS, w/lock washer | | | | | |
| | 211-0012-00 | | XB040000 | 2 | SCREW, 4-40 x 0.375 inch, PHS | | | | | |
| | 210-0004-00 | | XB040000 | 3 | WASHER, lock, internal, #4 | | | | | |
| | 210-0406-00 | | XB040000 | 4 | NUT, hex., 4-40 x 0.188 inch | | | | | |
| | | | | | - - - * - - - | | | | | |
| | 343-0097-00 | | XB040000 | 2 | CLAMP, transistor heatsink | | | | | |
| | 210-0717-00 | | XB040000 | 2 | RIVET | | | | | |
| | 210-0599-00 | | XB040000 | 4 | NUT, sleeve, 0.375-32 x 0.562 inch | | | | | |
| | 214-0368-00 | | XB040000 | 2 | SPRING, transistor heatsink holder | | | | | |
| | 131-0761-00 | | XB040000 | 1 | TERMINAL POST | | | | | |
| | 210-0205-00 | | XB040000 | 1 | LUG, solder, SE #8 | | | | | |
| | 407-1389-00 | | XB040000 | 1 | BRACKET, heatsink | | | | | |
| | | | | | (ATTACHING PARTS) | | | | | |
| | 211-0130-00 | | XB040000 | 2 | SCREW, 4-40 x 0.25 inch, HSS | | | | | |
| | | | | | - - - * - - - | | | | | |
| -155 | - - - - - | | | 1 | CIRCUIT BOARD ASSEMBLY--VERT MODE A4 | | | | | |
| | - - - - - | | | - | circuit board assembly includes: | | | | | |
| -156 | 352-0331-00 | | | 2 | HOLDER, lamp | | | | | |
| -157 | 260-1424-01 | | | 1 | SWITCH, pushbutton--VERT MODE | | | | | |
| | | | | | (ATTACHING PARTS) | | | | | |
| -158 | 361-0411-00 | | | 4 | SPACER, pushbutton switch | | | | | |
| | | | | | - - - * - - - | | | | | |
| -159 | 131-0608-00 | | | 8 | TERMINAL, pin | | | | | |
| -160 | 136-0252-04 | | | 12 | SOCKET, pin connector, 0.181 inch long | | | | | |
| -161 | 175-0828-00 | | | ft | WIRE, electrical, 5 wire ribbon, 4.75 inches | | | | | |
| | | | | | (ATTACHING PARTS) | | | | | |
| -162 | 211-0116-00 | | | 6 | SCREW, sems, 4-40 x 0.312 inch, PHB | | | | | |
| | | | | | - - - * - - - | | | | | |
| -163 | - - - - - | | | 1 | CIRCUIT BOARD ASSEMBLY--VERT PREAMP A3 | | | | | |
| | - - - - - | | | - | circuit board assembly includes: | | | | | |
| | 105-0421-00 | | | 1 | ACTUATOR ASSEMBLY, slide switch--MOMENTARY | | | | | |
| | - - - - - | | | - | actuator assembly includes: | | | | | |
| -164 | 105-0420-00 | | | 1 | ACTUATOR, slide switch | | | | | |
| -165 | 214-1779-00 | | | 1 | SPRING, helical | | | | | |
| -166 | 351-0359-00 | | | 1 | GUIDE, switch slide | | | | | |
| | 105-0423-00 | | | 1 | ACTUATOR ASSEMBLY, slide switch--BANDWIDTH LIMIT | | | | | |
| | - - - - - | | | - | actuator assembly includes: | | | | | |
| -167 | 213-0048-00 | | | 1 | SETSCREW, 4-40 x 0.125 inch, HSS | | | | | |
| -168 | 376-0146-00 | | | 1 | COUPLER, shaft | | | | | |
| -169 | 105-0422-00 | | | 1 | ACTUATOR, slide switch | | | | | |
| -170 | 351-0355-00 | | | 1 | GUIDE, switch slide | | | | | |
| -171 | 214-1126-00 ² | | | - | SPRING, flat, gold | | | | | |
| | 214-1126-01 ² | | | - | SPRING, flat, green | | | | | |
| | 214-1126-02 ² | | | - | SPRING, flat, red | | | | | |
| -172 | 214-1127-00 | | | 2 | ROLLER, detent | | | | | |

¹See Electrical Parts List for part number.

²Replace only with part bearing the same color code as the original part in your instrument.

FIGURE 2 CIRCUIT BOARDS (cont)

| Fig. & Index No. | Tektronix Part No. | Serial/Model No. | | Q † y | Description |
|------------------------|-----------------------|------------------|------|-------------|---|
| | | Eff | Disc | | |
| 2-173 | 131-0344-00 | | | 2 | CONNECTOR, feed-thru |
| -174 | 358-0176-00 | | | 2 | BUSHING, plastic |
| -175 | 131-1003-00 | | | 9 | CONNECTOR, plug, electrical |
| -176 | 200-0945-01 | | | 6 | COVER HALF, transistor, 2-56 thread |
| -177 | 200-0945-00 | | | 6 | COVER HALF, transistor (ATTACHING PARTS FOR EACH) |
| -178 | 211-0062-00 | | | 1 | SCREW, 2-56 x 0.312 inch, PHS - - - * - - - |
| -179 | 136-0252-01 | | | 2 | SOCKET, pin connector, 0.178 inch long |
| | 136-0252-04 | | | 153 | SOCKET, pin connector, 0.181 inch long |
| -180 | 352-0134-00 | | | 1 | HOLDER, coil |
| -181 | 214-0506-00 | | | 1 | TERMINAL, pin, 0.375 inch long |
| -182 | 214-0579-00 | | | 12 | TERMINAL, test point |
| -183 | 131-0608-00 | | | 1 | TERMINAL, pin, 0.365 inch long |
| -184 | 131-1030-00 | | | 4 | CONTACT ASSEMBLY, cam switch, bottom |
| | 131-1031-00 | | | 5 | CONTACT ASSEMBLY, cam switch, top |
| -185 | 210-0779-00 | | | 6 | RIVET, tubular, 0.115 inch long |
| -186 | 260-1208-00 | | | 1 | SWITCH, pushbutton--INVERT (ATTACHING PARTS) |
| -187 | 361-0411-00 | | | 2 | SPACER, pushbutton switch - - - * - - - |
| -188 | - - - - - | -1 | | 2 | RESISTOR, variable |
| -189 | - - - - - | -1 | | 2 | RESISTOR, variable, w/switch (ATTACHING PARTS FOR EACH) |
| -190 | 361-0515-00 | | | 1 | SPACER, switch, plastic (ATTACHING PARTS) |
| -191 | 211-0116-00 | | | 2 | SCREW, sems, 4-40 x 0.312 inch, PHB |
| | 131-1428-00 | XB040000 | | 1 | CLIP, ground |
| | 129-0413-00 | XB040000 | | 1 | POST, stud, 0.62 inch long |
| | 210-1002-00 | XB040000 | | 1 | WASHER, flat, 0.125 ID x 0.25 inch OD - - - * - - - |
| -192 | 384-1059-00 | | | 4 | SHAFT, extension, 6.581 inches long |
| -193 | 384-1162-00 | | | 1 | SHAFT, extension, w/knob, 11.42 inches long |
| -194 | 384-1129-00 | | | 6 | SHAFT, extension |
| -195 | 384-1149-00 | | | 2 | SHAFT, extension, 7 inches long |
| -196 | 384-1180-00 | | | 2 | SHAFT, extension, 6.40 inches long |
| -197 | 376-0029-00 | | | 2 | COUPLING, shaft, rigid - each coupling includes: |
| | 213-0075-00 | | | 2 | SETSCREW, 4-40 x 0.94 inch, HSS |
| -198 | 376-0051-00 | | | 2 | COUPLING, flexible - each coupling includes: |
| | 213-0022-00 | | | 2 | SETSCREW, 4-40 x 0.188 inch, HSS |
| -199 | 346-0102-00 | | | 1 | STRAP, grounding (ATTACHING PARTS) |
| -200 | 211-0116-00 | | | 1 | SCREW, sems, 4-40 x 0.312 inch, PHB - - - * - - - |
| -201 | - - - - - | -1 | | 2 | CIRCUIT BOARD ASSEMBLY--CH 1 & CH 2 ATTEN A1 & 2 - each circuit board assembly includes: |
| -202 | 105-0243-00 | | | 1 | LEVER, switch--AC DC (ATTACHING PARTS) |
| -203 | 213-0214-00 | | | 1 | SCREW, 2-56 x 0.375, CAP SOC |

¹See Electrical Parts List for part number.

FIGURE 2 CIRCUIT BOARDS (cont)

| Fig. & Index No. | Tektronix Part No. | Serial/Model No. | | Q † y | Description |
|------------------------|--------------------------|------------------|---------|-------------|---|
| | | Eff | Disc | | |
| | | | | | 1 2 3 4 5 |
| 2-204 | 131-0963-00 | | | 2 | CONTACT, electrical, grounding |
| -205 | 354-0391-00 | | | 2 | RING, retaining |
| -206 | 210-0406-00 | | | 10 | NUT, hex., 4-40 x 0.188 inch |
| -207 | 401-0081-02 | | | 1 | BEARING, cam switch, front (ATTACHING PARTS) |
| -208 | 211-0097-00 | | | 2 | SCREW, 4-40 x 0.312 inch, PHS |
| -209 | 210-0004-00 | | | 2 | WASHER, lock, internal, 0.12 ID x 0.26 inch OD - - - * - - - |
| -210 | 214-1127-00 | | | 4 | ROLLER, detent |
| -211 | 214-1139-00 ¹ | | | - | SPRING, flat, gold |
| | 214-1139-02 ¹ | | | - | SPRING, flat, green |
| | 214-1139-03 ¹ | | | - | SPRING, flat, red |
| -212 | 105-0282-00 | | | 1 | DRUM, cam switch |
| -213 | 401-0115-00 | | | 1 | BEARING, cam switch, center |
| -214 | 105-0342-00 | | | 1 | ACTUATOR, cam switch |
| -215 | 401-0081-02 | | | 1 | BEARING, cam switch, front |
| | 136-0333-00 | | | 1 | SOCKET, pin connector |
| -216 | 136-0252-01 | | | 12 | SOCKET, pin connector, 0.178 inch long |
| -217 | 131-1354-00 | | | 2 | LINK, terminal connecting |
| -218 | 337-1406-00 | | | 1 | SHIELD, electrical, cam contact |
| -219 | 131-1030-00 | | | 6 | CONTACT ASSEMBLY, cam switch, bottom |
| | 131-1031-00 | | | 8 | CONTACT ASSEMBLY, cam switch, top |
| -220 | 441-1095-00 | | | 1 | CHASSIS, attenuator (ATTACHING PARTS) |
| -221 | 211-0001-00 | | | 2 | SCREW, 2-56 x 0.25 inch, PHS |
| | 210-0938-00 | | | 1 | WASHER, flat, 0.109 ID x 0.25 inch OD |
| -222 | 210-0053-00 | | | 2 | WASHER, lock, split, 0.092 ID x 0.175 inch OD |
| -223 | 210-1008-00 | | | 2 | WASHER, flat, 0.90 ID x 0.188 inch OD |
| -224 | 210-0405-00 | | | 2 | NUT, hex., 2-56 x 0.188 inch |
| -225 | 129-0299-00 | | | 4 | POST, hex., 0.333 inch long |
| -226 | 210-0004-00 | | | 4 | WASHER, lock, internal, 0.12 ID x 0.26 inch OD - - - * - - - |
| -227 | 210-0261-00 | B010100 | B010679 | 1 | LUG, solder |
| | 210-0994-00 | B010680 | | 1 | WASHER, flat, 0.125 ID x 0.25 inch OD |
| -228 | 200-1438-00 | | | 1 | COVER, chassis, attenuator (ATTACHING PARTS) |
| -229 | 213-0055-00 | | | 3 | SCREW, thread forming, 2-32 x 0.188 inch, PHS |
| -230 | 210-0938-00 | | | 3 | WASHER, flat, 0.109 ID x 0.25 inch OD |
| -231 | 211-0008-00 | | | 4 | SCREW, 4-40 x 0.25 inch, PHS |
| -232 | 210-0994-00 | | | 4 | WASHER, flat, 0.125 ID x 0.25 inch OD - - - * - - - |
| -233 | 131-0679-00 | | | 1 | CONNECTOR, electrical, BNC, w/hardware (ATTACHING PARTS) |
| -234 | 220-0569-00 | | | 1 | NUT, knurled, 0.50 x 0.235 inch |
| -235 | 361-0424-00 | | | 1 | SPACER, ring (ATTACHING PARTS) |
| -236 | 211-0116-00 | | | 3 | SCREW, sems, 4-40 x 0.312 inch, PHB |
| -237 | 210-0586-00 | | | 3 | NUT, keps, 4-40 x 0.25 inch |

¹Replace only with part bearing the same color code as the original part in your instrument.

FIGURE 2 CIRCUIT BOARDS (cont)

| Fig. & Index No. | Tektronix Part No. | Serial/Model No. | | Q † y | Description |
|------------------------|-----------------------|------------------|---------|-------------|---|
| | | Eff | Disc | | |
| 2-238 | 337-1804-00 | | | 2 | SHIELD, electrical, attenuator |
| -239 | 175-0825-00 | | | ft | WIRE, electrical, 2 wire ribbon, 29.5 inches |
| -240 | 175-0826-00 | | | ft | WIRE, electrical, 3 wire ribbon, 3.5 inches |
| -241 | 175-0827-00 | | | ft | WIRE, electrical, 4 wire ribbon, 4 inches |
| -242 | 175-0828-00 | B010100 | B039999 | ft | WIRE, electrical, 5 wire ribbon, 13 inches |
| | 175-0828-00 | B040000 | | ft | WIRE, electrical, 5 wire ribbon, 18.5 inches |
| -243 | 175-0831-00 | | | ft | WIRE, electrical, 8 wire ribbon, 10.25 inches |
| -244 | 210-0774-00 | | | 3 | EYELET, metallic, 0.152 inch OD |
| -245 | 210-0775-00 | | | 3 | EYELET, metallic, 0.126 inch OD |
| -246 | 131-0707-00 | | | 46 | CONNECTOR, terminal |
| | 131-0371-00 | | | 2 | CONNECTOR, terminal (large) |
| -247 | 131-0472-01 | | | 4 | CONNECTOR, pin, female |
| -248 | 352-0169-00 | | | 4 | HOLDER, terminal connector, 2 wire |
| -249 | 352-0161-00 | | | 1 | HOLDER, terminal connector, 3 wire |
| -250 | 352-0162-00 | B010100 | B039999 | 1 | HOLDER, terminal connector, 4 wire |
| | 352-0162-00 | B040000 | | 2 | HOLDER, terminal connector, 4 wire |
| -251 | 352-0163-00 | B010100 | B039999 | 3 | HOLDER, terminal connector, 5 wire |
| | 352-0163-00 | B040000 | | 2 | HOLDER, terminal connector, 5 wire |
| -252 | 352-0166-00 | | | 2 | HOLDER, terminal connector, 8 wire |

| Fig. & Index No. | Tektronix Part No. | Serial/Model No. | | Q t y | Description |
|------------------------|-----------------------|------------------|------|-------------|---|
| | | Eff | Disc | | |
| 3-1 | 437-0141-00 | | | 1 | CABINET, oscilloscope |
| - | ----- | | | - | cabinet includes: |
| -2 | 348-0080-01 | | | 4 | FOOT, cabinet |
| -3 | 200-1412-00 | | | 1 | COVER, front |
| -4 | 200-0602-01 | | | 2 | COVER, handle latch |
| -5 | 367-0140-03 | | | 1 | HANDLE, carrying |
| - | ----- | | | - | mounting hardware: (not included w/handle) |
| -6 | 211-0512-00 | | | 4 | SCREW, 6-32 X 0.50 inch, 100° csk, FHS |
| -7 | 214-0516-00 | | | 2 | SPRING, handle index |
| -8 | 214-0513-00 | | | 2 | INDEX, handle ring |
| -9 | 214-0515-00 | | | 2 | INDEX HANDLE, hub |
| - | ----- | | | - | mounting hardware for each: (not included w/index handle) |
| -10 | 213-0182-00 | | | 1 | SCREW, 0.25-20 X 0.75 inch, Cap HS |
| -11 | 210-0805-00 | | | 1 | WASHER, flat, 0.204 ID X 0.438 inch OD |

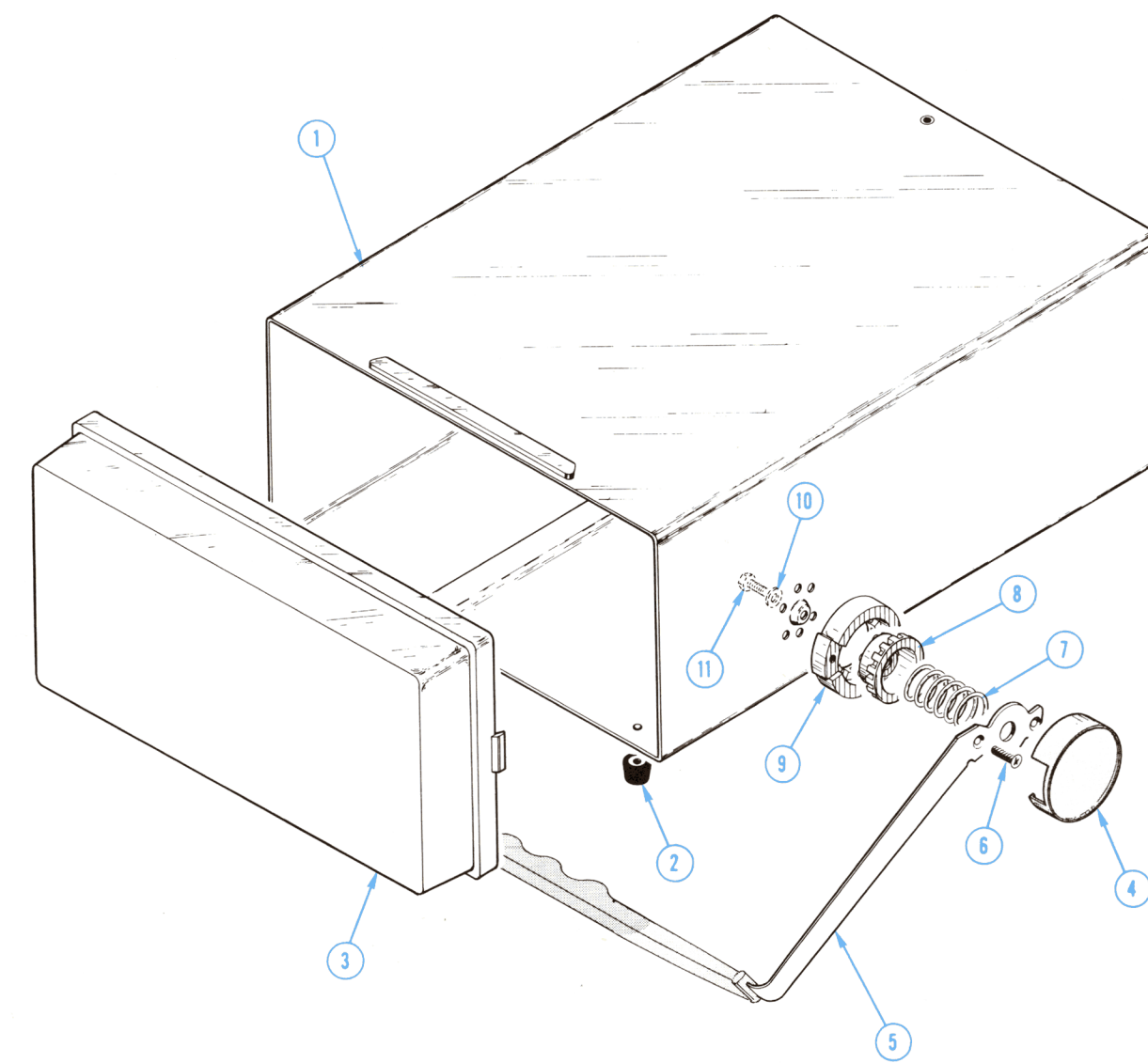

+

ACCESSORIES

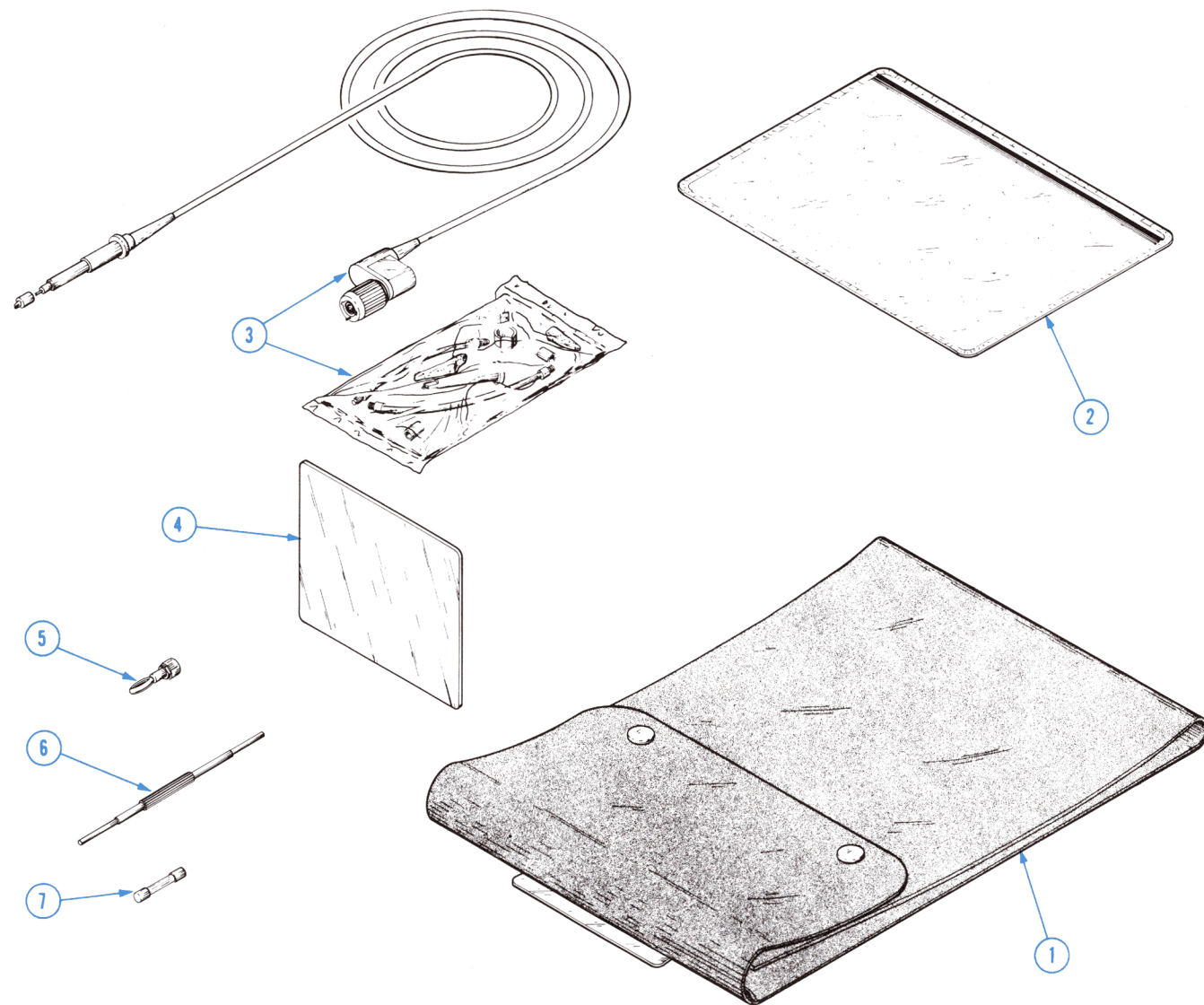

| Fig. & Index No. | Tektronix Part No. | Serial/Model No. | | Q | Description |
|------------------|--------------------|------------------|------|---|---------------------------------|
| | | Eff | Disc | | |
| STANDARD | | | | | |
| 4-1 | 016-0535-02 | | | 1 | POUCH, accessory, w/hdwr |
| -2 | 016-0537-00 | | | 1 | POUCH, accessory, w/zipper |
| -3 | 010-6065-03 | | | 2 | PROBE PACKAGE |
| -4 | 337-1674-01 | | | 1 | SHIELD, implosion, clear |
| -5 | 134-0016-01 | | | 1 | PLUG, tip, w/binding post |
| -6 | 003-0301-00 | | | 1 | TOOL, alignment |
| -7 | 159-0016-00 | | | 2 | FUSE, 1.5A, fast-blo |
| | 159-0042-00 | | | 2 | FUSE, 0.75A, fast-blo |
| | 070-1331-00 | | | 1 | MANUAL, instruction (not shown) |
| | 070-1331-00 | | | 1 | MANUAL, operators (not shown) |

465 OSCILLOSCOPE

REPACKAGING

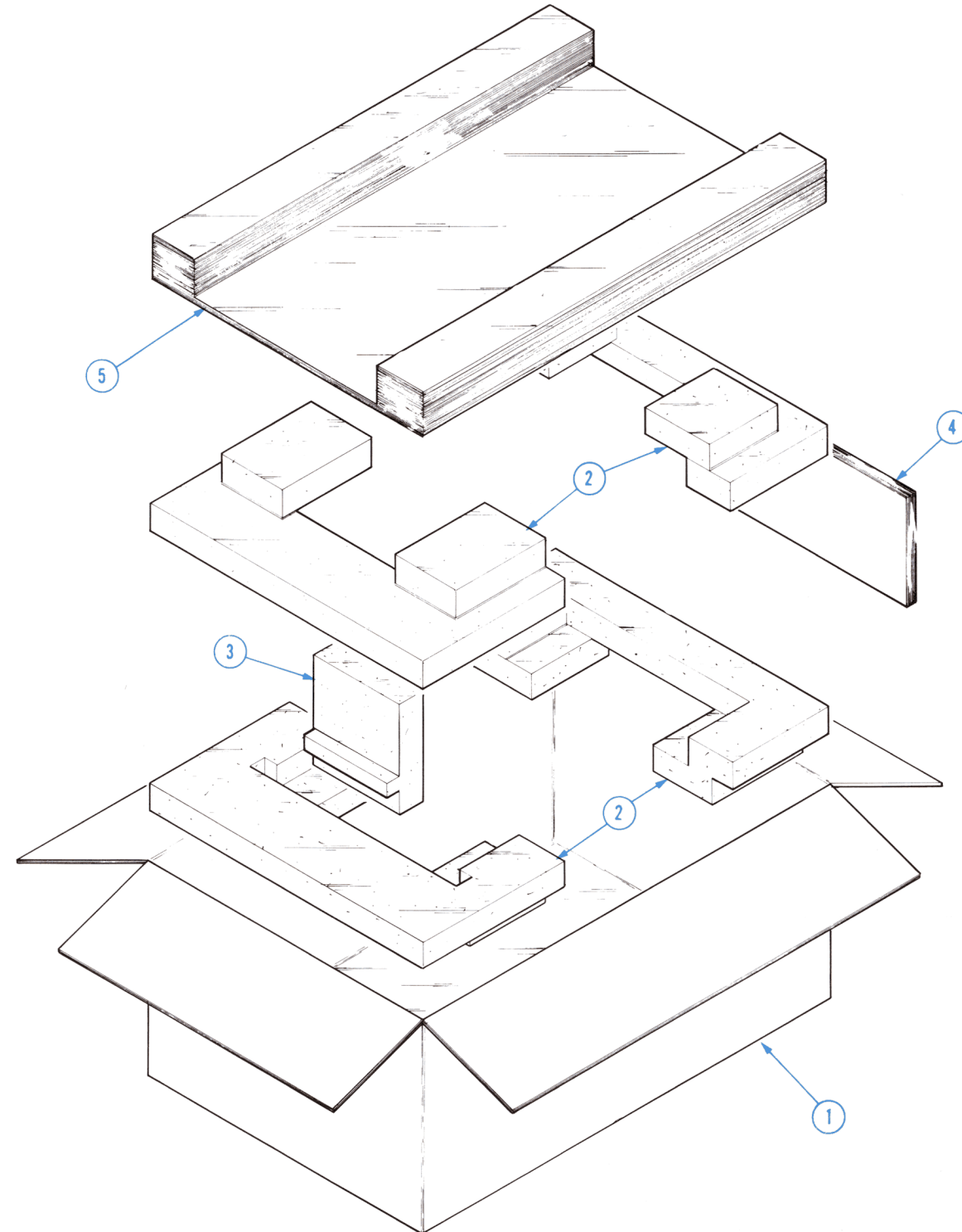

| Fig. & Index No. | Tektronix Part No. | Serial/Model No. | | Q | Description |
|------------------|--------------------|------------------|------|---|---------------------------|
| | | Eff | Disc | | |
| 5- | 065-0185-00 | | | 1 | CARTON ASSEMBLY |
| | | | | - | carton assembly includes: |
| -1 | 004-0850-00 | | | 1 | BOX |
| -2 | 004-1208-00 | | | 2 | FRAME |
| -3 | 004-1209-00 | | | 1 | FRAME, front pad |
| -4 | 004-1149-00 | | | 1 | PAD |
| -5 | 004-1158-00 | | | 1 | PAD |

+

MANUAL CHANGE INFORMATION

At Tektronix, we continually strive to keep up with latest electronic developments by adding circuit and component improvements to our instruments as soon as they are developed and tested.

Sometimes, due to printing and shipping requirements, we can't get these changes immediately into printed manuals. Hence, your manual may contain new change information on following pages.

A single change may affect several sections. Sections of the manual are often printed at different times, so some of the information on the change pages may already be in your manual. Since the change information sheets are carried in the manual until ALL changes are permanently entered, some duplication may occur. If no such change pages appear in this section, your manual is correct as printed.

ELECTRICAL PARTS LIST AND SCHEMATIC CORRECTIONS

CHANGE TO:

| | | |
|------|-------------|---------------------------|
| C18 | 281-0626-00 | 3.3 pF, Cer, 500 V |
| C33 | 281-0182-00 | 1.8-10 pF, Var |
| C47 | 281-0182-00 | 1.8-10 pF, Var |
| C48 | 281-0182-00 | 1.8-10 pF, Var |
| C68 | 281-0626-00 | 3.3 pF, Cer, 500 V |
| C83 | 281-0182-00 | 1.8-10 pF, Var |
| C97 | 281-0182-00 | 1.8-10 pF, Var |
| C98 | 281-0182-00 | 1.8-10 pF, Var |
| CR31 | 152-0153-00 | Silicon, FD7003 or CD5574 |
| CR32 | 152-0153-00 | Silicon, FD7003 or CD5574 |
| CR81 | 152-0153-00 | Silicon, FD7003 or CD5574 |
| CR82 | 152-0153-00 | Silicon, FD7003 or CD5574 |
| R18 | 315-0361-00 | 360 Ω , 1/4 W, 5% |
| R21 | 315-0470-00 | 47 Ω , 1/4 W, 5% |
| R51 | 315-0470-00 | 47 Ω , 1/4 W, 5% |
| R68 | 315-0361-00 | 360 Ω , 1/4 W, 5% |
| R676 | 315-0510-00 | 51 Ω , 1/4 W, 5% |

REMOVE:

| | | |
|------|-------------|-----------------------------------|
| C103 | 281-0604-00 | 2.2 pF, Cer, 500 V, ± 0.25 pF |
| C203 | 281-0604-00 | 2.2 pF, Cer, 500 V, ± 0.25 pF |



465 EFF SN B090000-up

ELECTRICAL PARTS LIST AND SCHEMATIC CORRECTION

CHANGE TO:

| | | |
|-------|-------------|--------------------------|
| C1307 | 281-0500-00 | 2.2 pF, Cer, 500 V |
| C1327 | 281-0500-00 | 2.2 pF, Cer, 500 V |
| R516 | 321-0481-00 | 1 M Ω , 1/8 W, 1% |

REMOVE:

| | | |
|-------|-------------|----------------------------------|
| C1469 | 281-0661-00 | 0.8 pF, Cer, 500 V, ± 0.1 pF |
|-------|-------------|----------------------------------|

ADD:

| | | |
|-------|-------------|--------------------------|
| R1315 | 315-0221-00 | 220 Ω , 1/4 W, 5% |
| R1335 | 315-0221-00 | 220 Ω , 1/4 W, 5% |

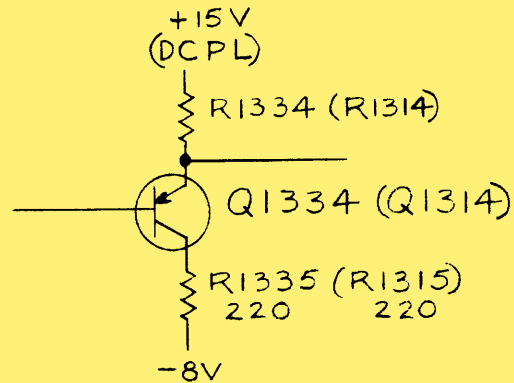

PARTIAL-
SWEEP & Z AXIS LOGIC



ELECTRICAL PARTS LIST AND SCHEMATIC CORRECTION

CHANGE TO:

| | | |
|--------|-------------|----------------------------------|
| A9 | 670-2233-03 | INTERFACE Circuit Board Assembly |
| C1512 | 290-0670-00 | 550 μ F x 100, Elect. |
| C1549 | 290-0529-00 | 47 μ F, Elect. 20 V |
| CR1514 | 152-0107-00 | Silicon, TI60 or 1N647 |
| VR1515 | 152-0268-00 | Zener, 1N979B, 0.4 W, 56 V, 5% |
| Q1534 | 151-0436-00 | Silicon, NPN MJ2801 |
| R1516 | 308-0363-00 | 3 k Ω , 8 W |

REMOVE:

| | | |
|--------|-------------|---|
| C1434 | 283-0005-00 | 0.01 μ F, Cer, 250 V, +100%-0% |
| CR1216 | 152-0141-02 | Silicon, 1N4152 |
| CR1513 | 152-0066-00 | Silicon, diffused, selected from 1N3194 |
| VR1434 | 152-0247-00 | Zener, 1N989B, 0.4 W, 150 V, 5% |
| VR1441 | 152-0283-00 | Zener, 1N976V, 0.4 W, 43 V, 5% |
| Q1514 | 151-0506-00 | SCR, 200 V, 4A, C106B2 |
| R1441 | 302-0562-00 | 5.6 k Ω , 1/2 W, 10% |
| R1460 | 311-1373-00 | 5 k Ω , Var |
| R1513 | 315-0222-00 | 2.2 k Ω , 1/4 W, 5% |
| R1512 | 316-0472-00 | 4.7 k Ω , 1/4 W, 10% |
| R1515 | 315-0102-00 | 1 k Ω , 1/4 W, 5% |

ADD:

| | | |
|--------|-------------|----------------------------|
| C1427 | 283-0002-00 | 0.01 μ F, Cer, 500 V |
| CR1218 | 152-0141-02 | Silicon, 1N4152 |
| CR1427 | 152-0107-00 | Silicon, TI60 or 1N647 |
| CR1516 | 152-0107-00 | Silicon, TI60 or 1N647 |
| Q1516 | 151-0311-01 | Silicon, NPN, MJE240 |
| Q1518 | 151-0347-00 | Silicon, NPN, 2N5551 |
| R1218 | 315-0152-00 | 1.5 k Ω , 1/4 W, 5% |

ADD:

| | | |
|--------|-------------|--------------------------------------|
| R1427 | 316-0106-00 | 10 M Ω , 1/4 W, 10% |
| R1460A | 311-1538-00 | 5 k Ω x 2.5 M Ω , dual |
| R1460B | 311-1538-00 | |
| R1517 | 315-0200-00 | 20 Ω , 1/4 W, 5% |
| R1518 | 303-0203-00 | 20 k Ω , 1 W, 5% |
| R1519 | 315-0101-00 | 100 Ω , 1/4 W, 5% |

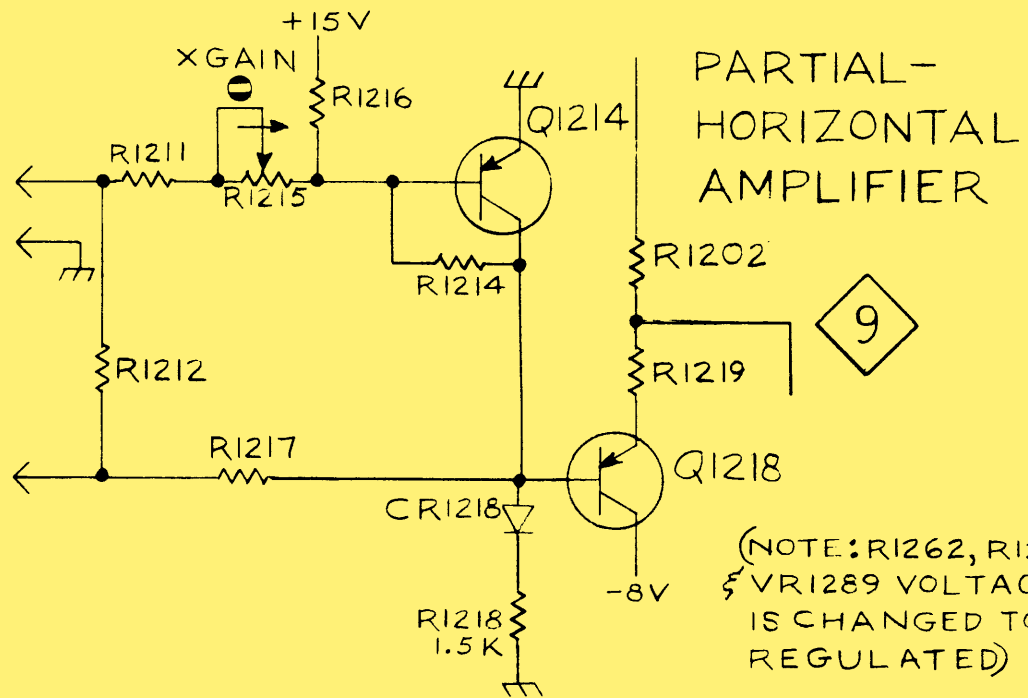

(R1460B GANGED WITH R1460A INTENSITY FORMERLY R1460)

465, M20,032

1-26-73

PARTIAL - CRT CIRCUIT

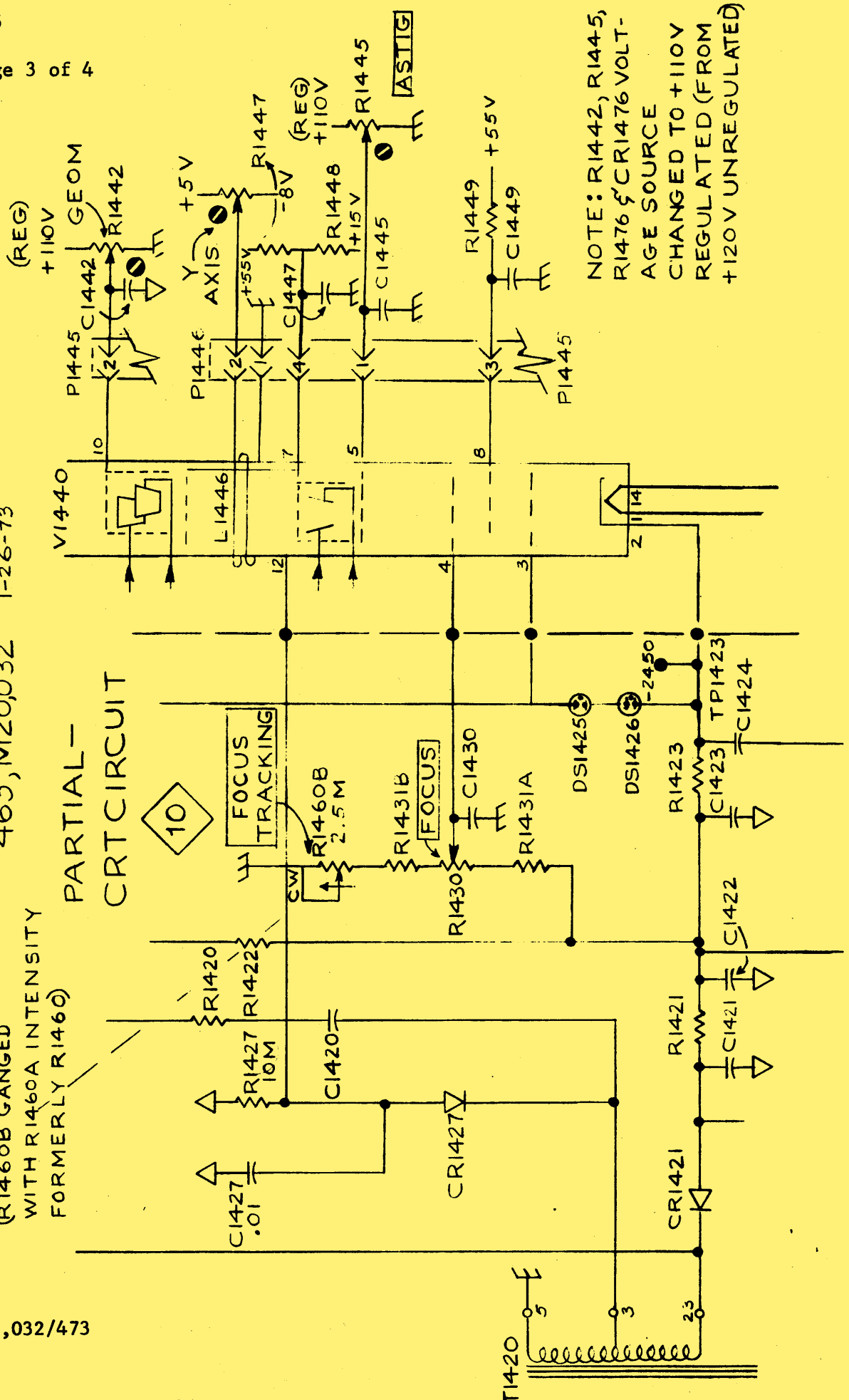

NOTE: R1442, R1445, R1476 & CR1476 VOLT-AGE SOURCE CHANGED TO +110V REGULATED (FROM +120V UNREGULATED)

Vertical Output Amplifier Circuit Description

The Vertical Output Amplifier is a three-stage paraphase amplifier. The first stage consists of transistors Q402, Q406, Q412 and Q416. The low-frequency compensation network, a portion of the high-frequency compensation network, and the Vert Out Center adjustment are in this stage. The next stage consists of transistors Q432, Q462, Q442 and Q472 with a thermal compensation network consisting of thermistor RT448, resistor R453 and varicap CR434 and capacitor C444 plus the remaining high-frequency compensation network. The final stage consists of transistors Q468, Q482, Q478 and Q492 with a gain adjustment R466. Capacitors C464 and C474 are built into the printed circuit board by lead and run capacitance.

BEAM FINDER

The BEAM FINDER switch, when pressed, limits the current to the emitters of transistors Q432 and Q442. This reduces the gain of the total stage, limiting the display to the display area without affecting the position of the display.

SECTION 5 PART II - SHORT-FORM CALIBRATION

VERTICAL SYSTEM CALIBRATION

7. Adjust Vertical Output Centering
 - a. Connect DC Voltmeter between TP322 and TP324.
 - b. Adjust CH 1 POSITION for 0 volt reading on the meter.
 - c. ADJUST - Vertical Output Centering, R429, to position the trace to the center graticule line.

8. Check BEAM FIND Operation

9. Adjust CH 1 Step Attenuator Balance
 - a. ADJUST - CH 1 Step Atten Bal, R25, for no more than 0.2 division trace shift when switching between 5 mV, 10 mV and 20 mV.
 - b. ADJUST - CH 1 Variable Balance, R120, for no more than 1 division trace shift when rotating the CH 1 VAR control through its range.
 - c. Check CH 1 UNCAL light.

10. Adjust CH 2 Step Attenuator Balance
 - a. ADJUST - CH 2 Step Atten Bal, R75, for no more than 0.2 division trace shift when switching between 5 mV, 10 mV, and 20 mV.
 - b. ADJUST - CH 2 Variable Balance, R220, for no more than 1 division trace shift when rotating the CH 1 VAR control through its range.

- c. Check CH 2 UNCAL light.
11. Check Probe Indicator Light
 - a. Connect a X10 probe to CH 1 input.
 - b. Check that the left light goes out and the right light comes on.
 - c. Repeat procedure for CH 2.
 12. Check CH 1 and 2 INPUT COUPLING Switch
 13. Adjust CH 1 and 2 Position Centering
 - a. VOLTS/DIV switches to 50 mV
INPUT COUPLING to AC
 - b. Connect a 2.4 division, 50 kHz signal from the Type 191 Medium-Frequency Constant-Amplitude Signal Generator.
 - c. VOLTS/DIV switch to 5 mV.
 - d. ADJUST - CH 1 Position Centering, R115, so the top and bottom of the display can be positioned past the center horizontal line.
 - e. Re-adjust R115 and R120 for minimum trace shift.
 - f. Repeat the above procedure for CH 2 - adjust R215.
 - g. Re-adjust R215 and R220 for minimum trace shift.
 14. Check CH 2 Invert Balance and Operation
 15. Adjust CH 1 and Vertical Output Gains
 - a. CH 1 VOLTS/DIV to 5 mV.

- b. Connect 20 mV signal from Standard Amplitude Calibrator to CH 1 input.
 - c. ADJUST - CH 1 Gain, R118, for 200 mV push-pull signal between TP322 and TP324.
 - d. ADJUST - Vertical Output Gain, R466, for 4 divisions deflection.
 - e. Check all attenuator ranges for proper deflection, within 3%.
 - f. Check Variable Range: CH 1 VAR control must reduce a 5 division signal to less than 2 divisions.
16. Adjust CH 2 Gain
- a. CH 2 VOLTS/DIV to 5 mV
 - b. Connect 20 mV signal from Standard Amplitude Calibrator to CH 2 input.
 - c. ADJUST - CH 2 Gain, R218, for 4 divisions deflection.
 - d. Check all attenuator ranges for proper deflection, within 3%.
 - e. Check Variable Range: CH 2 VAR control must reduce a 5 division signal to less than 2 divisions.
17. Check ADD Operation
- a. Both VOLTS/DIV to 5 mV
Both INPUT COUPLING switches to DC
 - b. Connect 10 mV from Standard Amplitude Calibrator to both CH inputs.
 - c. Set VERT MODE to ADD.

- d. Check for 4 divisions deflection, within $\pm 3\%$ unadjusted, or within $\pm 0.5\%$ adjusted.
18. Check Compression and Expansion
 - a. With 2 division signal, position to top and bottom of graticule.
 - b. Check for no more than 0.1 division of compression or expansion.
 19. Check Vertical Alternate Operation on All Sweep Speeds
 20. Check Vertical CHOP Operation
 - a. TIME/DIV to 1 μ s
VERT MODE to CHOP
 - b. Check for blanking of transients at normal INTENSITY level.
 - c. Check duration of each cycle is about 4 divisions.
 21. Adjust Vertical Output Low-Frequency Compensation
 - a. Connect the fast-rise output of the Square-Wave Generator (Type 106) to CH 1 input.
 - b. ADJUST - R425, R426 for best flat-top waveform using 100 KHz signal.
 22. Adjust VOLTS/DIV Compensation
 - a. Adjust CH 1 VOLTS/DIV Compensation for no more than 2% aberrations. Use 20 picofarad Normalizer and a 5 division signal at 1 KHz.

| | |
|-------|----------|
| 5 mV | C1 |
| 10 mV | Check |
| 20 mV | Check |
| 50 mV | C12, C13 |
| .1 V | Check |
| .2 V | Check |
| .5 V | C10, C11 |
| 1 V | Check |
| 2 V | Check |
| 5 V | Check |

b. Repeat procedure for CH 2.

23. Adjust Vertical Output High-Frequency Compensation

- a. VOLTS/DIV to 5 mV
A TIME/DIV to 0.05 μ s
- b. Adjust for a 5 division display from the Fast-Rise High-Amplitude Pulse Generator (Type 109) to CH 2 input.
- c. ADJUST - C77, C83, C205, R205, C249, R249, R427, R422, C422, R438, C438, for no more than 3% aberrations and a 3.5 nanosecond, or less, risetime.
- d. Check negative step aberrations, within 5%.
- e. CH 2 VOLTS/DIV to 10 mV
- f. ADJUST - R97, C97, for aberrations within 3% and 3.5 nanosecond, or less, risetime.
- g. Check negative step aberrations, within 5%.
- h. CH 2 VOLTS/DIV to 20 mV

- i. ADJUST - R98, C98, for aberrations within 3% and 3.5 nanosecond, or less, risetime.
 - j. Check negative step aberrations, within 5%.
 - k. Check remaining settings of CH 2 VOLTS/DIV switch for:
Positive step aberrations within 3%; risetime of 3.5 nanoseconds, or less; negative step aberrations within 5%.
 - l. Check position effect: Positive step aberrations within 5%, negative step aberrations within 7%.
24. Adjust CH 1 High-Frequency Compensation
- a. Repeat step 23-c with adjustments C27, C33, C105, R105, C122, R122, C149, and R149.
 - b. Adjust R47, C47 for step 23-f.
 - c. Adjust R48, C48 for step 23-i.
25. Check Vertical Amplifier Bandwidth
- a. Use the High-Frequency Constant-Amplitude Signal Generator (067-0532-01): 5 division display of 3 MHz reference signal.
 - b. From 5 mV to 5 V settings of both VOLTS/DIV switches, check frequency is at least 100 MHz (0°C to + 40°C) when display is reduced to 3.5 division.
26. Check Cascaded Bandwidth and Sensitivity
- a. Connect CH 1 OUT to CH 2 input through a terminated cable.
 - b. Check sensitivity is at least 1 mV/division.
 - c. Check Bandwidth is at least 50 MHz.

27. Check Vertical Channel Isolation and CMRR
 - a. Channel isolation: at least 100:1 at 25 MHz.
 - b. CMRR: at least 10:1 at 20 MHz for signals of 6 divisions or less.

28. Check Bandwidth Limit Operation
 - a. Connect 6 division display of a 50 kHz signal to CH 1 input.
 - b. Check frequency is 20 MHz, within 4 MHz, when display is reduced to 4.2 divisions.

SECTION 5

PART III - CALIBRATION

VERTICAL SYSTEM CALIBRATION

9. Adjust Vertical Output Centering and Check BEAM FIND
 - a. Connect the DC Voltmeter between TP322 and TP324 (see Fig. 5-8).
 - b. Adjust the CH 1 POSITION control for 0 volt reading on the meter.
 - c. ADJUST - Vertical Output Centering adjustment, R429, to position the trace to the center graticule line.
 - d. Remove the DC Voltmeter lead connections.
 - e. Position the trace off-screen with the CH 1 POSITION and horizontal POSITION controls.
 - f. Push the BEAM FIND button and hold it in.
 - g. CHECK - That the trace is brought into the CRT viewing area.
 - h. Release the BEAM FIND button.

10. Adjust CH 1 Step Attenuator Balance
 - a. Set the CH 1 VOLTS/DIV switch to 20 mV and the CH 1 INPUT COUPLING switch to GND.
 - b. Position the trace to the center horizontal graticule line.
 - c. CHECK - CRT display for 0.2 division or less of trace shift between adjacent switch positions when rotating the CH 1 VOLTS /DIV switch from 20 mV to 5 mV.

- d. ADJUST - CH 1 Step Atten Bal adjustment, R25, (see Fig. 5-10) for minimum trace shift when rotating the CH 1 VOLTS/DIV switch from 20 mV to 5 mV.
11. Adjust CH 1 Variable Volts/Division Balance
 - a. Position the trace to the center horizontal graticule line.
 - b. CHECK - That the CH 1 UNCAL light comes on when the VAR control is out of the detent position.
 - c. CHECK - CRT display for 1 division or less of trace shift when rotating the CH 1 VAR control through its range.
 - d. ADJUST - CH 1 Variable Balance adjustment, R120 (see Fig. 5-11) for minimum trace shift when rotating the CH 1 VAR control through its range.
 - e. Return the CH 1 VAR control to the detent position.

 12. Adjust CH 1 Position Centering
 - a. Set the CH 1 VOLTS/DIV switch to 50 mV.
 - b. Connect the output of the Medium-Frequency Constant-Amplitude Signal Generator (Type 191) to the CH 1 input via a GR-to-BNC adapter, a 42-inch 50 Ω BNC cable, and a 50 Ω BNC termination.

- c. Adjust the Medium-Frequency signal generator for a 2.4 division, 50 kHz output signal.
 - d. Switch the CH 1 VOLTS/DIV to the 5 mV setting.
 - e. CHECK - The top of the CRT display can be positioned below the center horizontal graticule line, and that the bottom of the display can be positioned above the center horizontal graticule line.
 - f. ADJUST - CH 1 Position Centering adjustment, R115, (See Fig. 5-11) so the top of the CRT display can be positioned below the center horizontal graticule line and the bottom of the display can be positioned above the center horizontal graticule line.
 - g. INTERACTION - Between CH 1 Position Centering and CH 1 Variable Volts/Division Balance adjustments. Readjust both until no interaction is visible.
13. Adjust CH 2 Step Attenuator Balance
- a. Connect the output of the Standard Amplitude Calibrator to the CH 2 input via a 42-inch 50 Ω BNC cable.
 - b. Set the VERT MODE switch to CH 2; CH 2 VOLTS/DIV switch to 20 mV.
 - c. Position the trace to the center horizontal graticule line.
 - d. CHECK - CRT display for 0.2 division or less of trace shift between adjacent switch positions when rotating the CH 2 VOLTS/DIV switch from 20 mV to 5 mV.

- e. ADJUST - CH 2 Step Atten Bal adjustment, R75, (See Fig. 5-12) for minimum trace shift when rotating the CH 2 VOLTS/DIV switch from 20 mV to 5 mV.
14. Adjust CH 2 Variable Volts/Division Balance
- a. CHECK - That the CH 2 UNCAL light comes on when the CH 2 VAR control is out of the detent position.
 - b. CHECK - CRT display for 1 division or less of trace shift when rotating the CH 2 VAR control through its range.
 - c. ADJUST - CH 2 Variable Balance adjustment, R220, (see Fig. 5-13) for minimum trace shift when rotating the CH 2 VAR control through its range.
 - d. Return the VAR control to the detent position.
 - e. Disconnect the CH 2 test setup.
15. Adjust CH 2 Position Centering
- a. Move the test signal from CH 1 to the CH 2 input.
 - b. Set the CH 2 VOLTS/DIV switch to 50 mV; and the VERT MODE switch to CH 2.
 - c. Adjust the Medium-Frequency signal generator for a 2.4 division, 50 kHz output signal.
 - d. Set the CH 2 VOLTS/DIV switch to 5 mV.
 - e. CHECK - Top of CRT display can be positioned below the center horizontal graticule line, and the bottom of the display can be positioned above the center horizontal graticule line.

- f. ADJUST - CH 2 Position Centering adjustment, R215, (see Fig. 5-13) so that the top of the CRT display can be positioned below the center horizontal graticule line, and the bottom of the display can be positioned above the center horizontal graticule line.
 - g. INTERACTION - Between CH 2 Position Centering and CH 2 Variable Volts/Division Balance adjustments. Readjust both until no interaction occurs.
16. Check CH 2 INVERT Balance
- a. Set the CH 2 INPUT COUPLING switch to GND.
 - b. Position the trace to the center horizontal graticule line.
 - c. Push the INVERT button.
 - d. CHECK - For less than 2 divisions of trace shift when switching from normal to inverted.
17. Check Probe Indicator Lights
- a. Set both VOLTS/DIV switches to 5 mV.
 - b. Connect the 465's X10 probe to the CH 1 input.
 - c. CHECK - Light under 5 mV is extinguished and the light under 50 mV comes on.
 - d. Set VERT MODE switch to CH 2.
 - e. Move the probe to the CH 2 input.
 - f. CHECK - Light under 5 mV is extinguished and the light under 50 mV comes on.
 - g. Remove the X10 probe.

18. Check INPUT COUPLING Switches

- a. Set both INPUT COUPLING switches to DC.
- b. Connect the Standard Amplitude Calibrator output to the CH 2 input via a 42-inch 50 Ω BNC cable.
- c. Adjust the Standard Amplitude Calibrator for 20 mV output.
- d. Position the bottom of the display to the center horizontal graticule line.
- e. Set CH 2 INPUT COUPLING switch to GND.
- f. CHECK - For no vertical deflection; trace is at center horizontal graticule line.
- g. Set CH 2 INPUT COUPLING switch to AC.
- h. CHECK - That display is centered about the center horizontal graticule line.
- i. Move the test signal to CH 1.
- j. Position the bottom of the display to the center horizontal graticule line.
- k. Set CH 1 INPUT COUPLING switch to GND.
- l. Repeat step 13-f.
- m. Set CH 1 INPUT COUPLING switch to AC.
- n. Repeat step 13-h.
- o. Disconnect the test setup.

19. Adjust CH 1 and Vertical Output Gains

- a. Set the VERT MODE switch to CH 1, the CH 1 VOLTS/DIV switch to 5 mV, and the CH 1 INPUT COUPLING switch to DC.
- b. Connect the output of the Standard Amplitude Calibrator to the CH 1 input via a 42-inch 50 Ω BNC cable.
- c. Adjust the Standard Amplitude Calibrator for a 20 mV output.
- d. Set the Test Oscilloscope: Vertical Mode to ADD, Channel 2 to INVERT, and both VOLTS/DIV switches to 5 mV.

- e. Connect two X10 probes from the Test Oscilloscope to TP322 and TP324 on the Preamp board of the 465 (see Fig. 5-8).
 - f. CHECK - The Test Oscilloscope for a 200 mV (peak-to-peak) signal between TP322 and TP324.
 - g. ADJUST - CH 1 Gain adjustment, R118, (see Fig. 5-14) for 200 mV (peak-to-peak) display on the Test Oscilloscope. (NOTE: This is a nominal value for this adjustment and may vary from instrument to instrument.)
 - h. Remove the X10 probes from TP322 and TP324.
 - i. CHECK - CRT display for 4 divisions of deflection within 3% (0.12 division).
 - j. ADJUST - Vertical Output Gain adjustment, R466, for 4 divisions of deflection.
 - k. CHECK - Accuracy of CH 1 VOLTS/DIV switch using the settings given in Table 5-6 to see if the deflection factor accuracy for each position is within 3%.
20. Adjust CH 2 Gain
- a. Set the CH 2 VOLTS/DIV switch to 5 mV, the VERT MODE switch to CH 2, and the CH 2 INPUT COUPLING switch to DC.
 - b. Move the test signal to CH 2 input connector.
 - c. Adjust the Standard Amplitude Calibrator for a 20 mV output.
 - d. CHECK - CRT display for 4 divisions of deflection within 3%.
 - e. ADJUST - CH 2 Gain adjustment, R218, (see Fig. 5-16) for 4 divisions of deflection.

- f. CHECK - Accuracy of the CH 2 VOLTS/DIV switch using the settings given in Table 5-6. Deflection factor accuracy to be within 3% in all switch positions.
21. Check CH 2 and CH 1 Variable Volts/Division Ranges
- a. Adjust the Standard Amplitude Calibrator for 5 divisions of deflection.
 - b. Rotate the CH 2 VAR control fully counterclockwise.
 - c. CHECK - CRT display reduces to less than 2 divisions.
 - d. Move the test signal to the CH 1 input connector.
 - e. Set the VERT MODE switch to CH 1.
 - f. Adjust the Standard Amplitude Calibrator for 5 divisions of deflection.
 - g. Rotate the CH 1 VAR control fully counterclockwise.
 - h. CHECK - CRT display reduces to less than 2 divisions.
 - i. Return the VAR controls to the detent positions.
22. Check Vertical ADD Mode Operation
- a. Set both VOLTS/DIV switches to 5 mV and both INPUT COUPLING switches to DC.
 - b. Connect the Standard Amplitude Calibrator output to both channel inputs via a dual input coupler.
 - c. Adjust the Standard Amplitude Calibrator for a 10 mV output.
 - d. Set the VERT MODE switch to ADD.
 - e. CHECK - For 4 divisions of deflection, within $\pm 3\%$ unadjusted, or $\pm 0.5\%$ adjusted.

23. Check Compression and Expansion
 - a. Set the CH 2 INPUT COUPLING switch to GND and the VERT MODE switch to CH 1.
 - b. Adjust the CH 1 VAR control for 2 divisions of deflection centered about the center horizontal graticule line.
 - c. Position the top of the display to the top graticule line.
 - d. CHECK - CRT display for 0.1 division or less of compression or expansion.
 - e. Position the bottom of the display to the bottom graticule line.
 - f. CHECK - CRT display for 0.1 division or less of compression or expansion.
 - g. Set the CH 1 VAR control to the detent position.
 - h. Disconnect the test setup.

24. Check Vertical ALT Mode Operation
 - a. Set the VERT MODE switch to ALT, and the A Trigger LEVEL control fully clockwise.
 - b. Position the two traces 2 divisions apart.
 - c. CHECK - That the sweeps alternate at all settings of the A TIME/DIV switch except X-Y.

25. Check Vertical CHOP Mode Operation
 - a. Set the A TIME/DIV switch to 1 μ s, the A SOURCE switch to NORM, the A SLOPE switch to +, the VERT MODE switch to CHOP, and both INPUT COUPLING switches to GND.
 - b. Position the two traces about 4 divisions apart.

- c. Adjust the A LEVEL control for a stable display.
 - d. CHECK - For complete blanking of switching transients between chopped segments (see Fig. 5-17).
 - e. CHECK - Duration of each cycle is about four divisions.
26. Adjust Vertical Output Low-Frequency Compensation
- a. Set the A TIME/DIV switch to 20 μ s, the VERT MODE switch to CH 1, both INPUT COUPLING switches to DC, and both VOLTS/DIV switches to 5 mV.
 - b. Connect the fast-rise output of the Square-Wave Generator (Type 106) to the CH 1 input via a GR-to-BNC adapter, 42-inch 50 Ω BNC cable, a X10 BNC attenuator, and a 50 Ω BNC termination.
 - c. Adjust the Square-Wave Generator for a 5 division 100 kHz output signal.
 - d. CHECK - CRT display for flat-top waveform with no more than 3% overshoot or roll-off on the leading edge.
 - e. ADJUST - R425, R426 for best flat-top waveform.
 - f. INTERACTION - Between adjustments in this step. Readjust if necessary for total optimum response.
27. Adjust CH 1 VOLTS/DIV Compensation
- a. Add a 20 pf Normalizer to the test setup between the 50 Ω BNC termination and the CH 1 input.
 - b. Move the test setup from the fast-rise output to the high-amplitude output of the Square-Wave Generator (Type 106).

- c. Adjust the Square-Wave Generator for a five division 1 kHz display. Add or remove attenuators as necessary to maintain a five division display throughout this step.
- d. CHECK - CRT display for flat-top waveform with no more than 2% overshoot or roll-off on the leading edge.
- e. ADJUST - C1 (see Fig. 5-19) with a low-capacitance screwdriver, for best flat-top waveform.
- f. Set the CH 1 VOLTS/DIV switch to 50 mV.
- g. CHECK - CRT display for flat-top waveform with no more than 2% overshoot or roll-off on the leading edge.
- h. ADJUST - Channel 1 C13 (see Fig. 5-19) for best flat-top waveform, and Channel 1 C12 for the best corner with a low-capacitance screwdriver.
- i. CAL AID - Remove the 20 pf Normalizer when adjusting or checking the corner response.
- j. INTERACTION - Between Channel 1's C13 and C12. Readjust both for total optimum response.
- k. Set the CH 1 VOLTS/DIV switch to 0.5V.
- l. CHECK - CRT display for flat-top waveform with no more than 2% overshoot or roll-off on the leading edge.
- m. ADJUST - Channel 1 C11 (see Fig. 5-19) for best flat-top waveform, and Channel 1 C10 for the best corner, with the low-capacitance screwdriver.
- n. Set the CH 1 VOLTS/DIV switch to 5 V.
- o. CHECK - CRT display for flat-top waveform with no more than 2% overshoot or roll-off on the leading edge.

28. Adjust CH 2 VOLTS/DIV Compensation
 - a. Set the VERT MODE switch to CH 2 and move the test signal to the CH 2 input.
 - b. Adjust the Square-Wave Generator (Type 106) for a five division display. Remove or add attenuators as necessary to maintain a five division display.
 - c. CHECK - CRT display for flat-top waveform with no more than 2% overshoot or roll-off on the leading edge.
 - d. ADJUST - C51 (see Fig. 5-20) with the low-capacitance screwdriver, for best flat-top waveform.
 - e. Set the CH 2 VOLTS/DIV switch to 50 mV.
 - f. CHECK - CRT display for flat-top waveform with no more than 2% overshoot or roll-off on the leading edge.
 - g. ADJUST - Channel 2 C13 (see Fig. 5-20) for the best flat-top waveform, and Channel 2 C12 for the best corner, with the low-capacitance screwdriver.
 - h. CAL AID - Remove the 20 pf Normalizer when adjusting or checking the corner response.
 - i. INTERACTION - Between Channel 2's C13 and C12. Readjust both for total optimum response.
 - j. Set the CH 2 VOLTS/DIV switch to 0.5 V.
 - k. CHECK - CRT display for flat-top waveform with no more than 2% overshoot or roll-off on the leading edge.
 - l. ADJUST - Channel 2 C11 (see Fig. 5-20) for best flat-top waveform, and Channel 2 C10 for the best corner, with the low-capacitance screwdriver.
 - m. INTERACTION - Between Channel 2's C11 and C10. Readjust both for optimum response.

- n. Set the CH 2 VOLTS/DIV switch to 5 V.
 - o. CHECK - CRT display for flat-top waveform with no more than 2% overshoot or roll-off on the leading edge.
 - p. Disconnect the test setup.
29. Adjust Channel 2 and Vertical Output High-Frequency Compensation
- a. Set both VOLTS/DIV switches to 5 mV, the VERT MODE switch to CH 2, the A TIME/DIV switch to 0.05 μ s, and the A SLOPE TO +.
 - b. Connect the Fast-Rise High-Amplitude Pulse Generator (Type 109) to the CH 2 input via a GR-to-BNC adapter, 42-inch 50 Ω BNC cable, two X10 BNC attenuators, and a 50 Ω BNC termination.
 - c. Set the Pulse Generator polarity to + and the voltage range to 50 V.
 - d. Adjust the Pulse Generator for five divisions of deflection. Remove or add attenuators as necessary to maintain a five division display throughout this step.
 - e. CHECK - CRT display for risetime of 3.5 nanoseconds or less.
 - f. CHECK - CRT display for flat-top waveform with 3% or less of aberrations.
 - g. ADJUST - C77, C83, C205, R205, C249, R249, R422, C422, R438, C438 and R427, with a low-capacitance screwdriver, for the best flat-top waveform (see Fig. 5-21).

- h. Set the Pulse Generator polarity to - and the 465 A SLOPE switch to -.
- i. CHECK - CRT display for flat-bottom waveform with 5% or less of aberrations.
- j. CAL AID - The above adjustments also affect the negative-step aberrations. Adjust for optimum response and minimum aberrations on both the positive- and negative-going steps.
- k. Set the A SLOPE control to + and the Pulse Generator polarity to +.
- l. Set the CH 2 VOLTS/DIV switch to 10 mV.
- m. CHECK - CRT display for risetime of 3.5 nanoseconds or less.
- n. CHECK - CRT display for flat-top waveform with 3% or less of aberrations.
- o. ADJUST - R97 and C97 (see Fig. 5-21) for optimum risetime and aberrations.
- p. Set the Pulse Generator polarity to - and the 465 A SLOPE switch to -.
- q. CHECK - CRT display for best corner and flat-bottom waveform with 5% or less aberrations.
- r. Set the CH 2 VOLTS/DIV switch to 20 mV and the A SLOPE switch to +.
- s. Set the Pulse Generator to +.
- t. CHECK - CRT display for risetime of 3.5 nanoseconds or less.

- u. CHECK - CRT display for flat-top waveform with 3% or less of aberrations.
 - v. ADJUST - R98 and C98 (see Fig. 5-21) for optimum risetime and aberrations.
 - w. Set the Pulse Generator polarity to - and the 465 A SLOPE switch to -.
 - x. CHECK - CRT display for flat-bottom waveform with 5% or less of aberrations.
 - y. Set the CH 2 VOLTS/DIV switch to 50 mV.
 - z. Set the A SLOPE switch to + and the Pulse Generator polarity to +.
 - aa. CHECK - CRT display for risetime of 3.5 nanoseconds or less.
 - ab. CHECK - CRT display for flat-top waveform with 3% or less of aberrations.
 - ac. Set the Pulse Generator polarity to - and the 465 A SLOPE switch to -.
 - ad. CHECK - CRT display for best corner and flat-bottom waveform with 5% or less aberrations.
 - ae. Repeat step 29-z through 29-ad for each setting of the CH 2 VOLTS/DIV switch from 0.1 V to 5 V.
30. Check CH 2 Position Effect
- a. Set the CH 2 VOLTS/DIV switch to 5 mV.
 - b. Adjust the Pulse Generator (Type 109) for five divisions of display.

- c. Adjust the A LEVEL control for a stable display.
 - d. Position the top of the display to the bottom graticule line.
 - e. CHECK - CRT display for less than 5% aberrations.
 - f. Set the Pulse Generator polarity to - and the 465 A SLOPE switch to -.
 - g. Position the bottom of the display to the top graticule line.
 - h. CHECK - CRT display for less than 7% aberrations.
31. Adjust CH 1 High-Frequency Compensation
- a. Move the test signal from CH 2 to the CH 1 input.
 - b. Set the A TIME/DIV switch to 0.05 μ s, the A SLOPE switch to +, and the VERT MODE switch to CH 1.
 - c. Set the Fast-Rise High-Amplitude Pulse Generator (Type 109) to + and adjust the Pulse Generator for five divisions of deflection. Remove or add attenuators as necessary to maintain a five division display throughout this step.
 - d. CHECK - CRT display for risetime of 3.5 nanoseconds or less.
 - e. CHECK - CRT display for flat-top waveform with 3% or less of aberrations.
 - f. ADJUST - C27, C33, C105, R105, R122, C122, C149, and R149 (see Fig. 5-23) with a low-capacitance screwdriver, for the best flat-top waveform.
 - g. Set the Pulse Generator polarity to - and the 465 A SLOPE switch to -.

- h. CHECK - CRT display for flat-bottom waveform with 5% or less of aberrations.
- i. CAL AID - The above adjustments also affect the negative-step aberrations. Adjust them for optimum response and minimum aberrations on both the positive-and negative-going steps.
- j. Set the A SLOPE control to + and the Pulse Generator polarity to +.
- k. Set the CH 1 VOLTS/DIV switch to 10 mV.
- l. CHECK - CRT display for risetime of 3.5 nanoseconds or less.
- m. CHECK - CRT display for flat-top waveform with 3% or less of aberrations.
- n. ADJUST - R47 and C47 (see Fig. 5-23) for optimum risetime and aberrations.
- o. Set the Pulse Generator polarity to - and the 465 A SLOPE switch to -.
- p. CHECK - CRT display for best corner and flat-bottom waveform with 5% or less aberrations.
- q. Set the CH 1 VOLTS/DIV switch to 20 mV and the A SLOPE switch to +.
- r. Set the Pulse Generator polarity to +.
- s. CHECK - CRT display for risetime of 3.5 nanoseconds or less.
- t. CHECK - CRT display for flat-top waveform with 3% or less of aberrations.

- u. ADJUST - R48 and C48 (see Fig. 5-23) for optimum rise-time and aberrations.
 - v. Set the Pulse Generator polarity to - and the 465 A SLOPE switch to -.
 - w. CHECK - CRT display for flat-bottom waveform with 5% or less of aberrations.
 - x. Set the CH 1 VOLTS/DIV switch to 50 mV.
 - y. Set the A SLOPE switch to + and the Pulse Generator polarity to +.
 - z. CHECK - CRT display for risetime of 3.5 nanoseconds or less.
 - aa. CHECK - CRT display for flat-top waveform with 3% or less of aberrations.
 - ab. Set the Pulse Generator polarity to - and the 465 A SLOPE switch to -.
 - ac. CHECK - CRT display for best corner and flat-bottom waveform with 5% or less aberrations.
 - ad. Repeat step 31-y through 31-ac for each setting of the CH 1 VOLTS/DIV switch from 0.1 V to 5 V.
32. Check CH 1 Position Effect
- a. Set the CH 1 VOLTS/DIV switch to 5 mV.
 - b. Adjust the Pulse Generator (Type 109) for five divisions of display.
 - c. Adjust the A LEVEL control for a stable display.
 - d. Position the top of the display to the bottom graticule line.

- e. CHECK - CRT display for less than 5% aberrations.
- f. Set the Pulse Generator polarity to - and the 465 A SLOPE switch to -.
- g. Position the bottom of the display to the top graticule line.
- h. CHECK - CRT display for less than 7% aberrations.
- i. Disconnect the test setup.

33. Check Vertical Amplifier Bandwidth

- a. Connect the output of the High-Frequency Constant-Amplitude Signal Generator (067-0532-01) to the CH 1 input via a GR-to-BNC adapter, X10 BNC attenuator, and a 50 Ω BNC termination.
- b. Set the TRIG MODE switch to AUTO, A TIME/DIV switch to 0.2 ms, both VOLTS/DIV switches to 5 mV and the VERT MODE switch to CH 1.
- c. Adjust the High-Frequency signal generator output amplitude for a five division display of a 3 megahertz reference signal.
- d. Without changing the output amplitude, increase the output frequency of the signal generator until the display is reduced to 3.5 divisions.
- e. CHECK - Output frequency of the signal generator must be at least 100 megahertz (0°C to +40°C).
- f. Repeat this bandwidth check procedure, steps 33-c through 33-e, for settings of the CH 1 VOLTS/DIV switch from 10 mV to 2 V.

- g. Move the test signal to CH 2 input, set the VERT MODE switch to CH 2, and the CH 2 INPUT COUPLING switch to DC.
 - h. Repeat this bandwidth check, step 33-c through 33-e, for settings of the CH 2 VOLTS/DIV switch from 5 mV to 2 V.
 - i. Disconnect the test setup.
34. Check Cascaded Gain and Bandwidth
- a. Set both INPUT COUPLING switches to DC, the VERT MODE switch to CH 2, both VOLTS/DIV switches to 5 mV, and the A TIME/DIV switch to 1 ms.
 - b. Connect the CH 1 VERT SIGNAL OUT (on the rear panel) to the CH 2 input connector via a 42-inch 50 Ω BNC cable and a 50 Ω BNC termination.
 - c. Connect the Standard Amplitude Calibrator to the CH 1 input via a 42-inch 50 Ω BNC cable.
 - d. Adjust the Standard Amplitude Calibrator for a 5 mV output.
 - e. CHECK - CRT display for at least five divisions of deflection.
 - f. Remove the test setup from the CH 1 input.
 - g. Connect the output of the Medium-Frequency Constant-Amplitude Signal Generator (Type 191) to the CH 1 input via a GR-to-BNC adapter, 42-inch 50 Ω BNC cable, X10 BNC attenuator, and a 50 Ω BNC termination.
 - h. Adjust the Medium-Frequency signal generator for a five division display of a 50 kilohertz reference signal.

- i. Without changing the output amplitude of the signal generator, increase the output frequency until the display is reduced to 3.5 divisions.
 - j. CHECK - Output frequency of the signal generator must be at least 50 megahertz.
 - k. Disconnect the test setup.
35. Check Vertical Channel Isolation
- a. Move the test signal to the CH 2 input after removing the X10 attenuator.
 - b. Set CH 2 VOLTS/DIV switch to 0.2 V, CH 1 INPUT COUPLING switch to GND, and VERT MODE switch to CH 2.
 - c. Adjust the Medium-Frequency signal generator for a 2 division display of a 25 megahertz signal.
 - d. Set both VOLTS/DIV switches to 20 mV and VERT MODE switch to CH 1.
 - e. CHECK - CRT display for no more than 0.2 division of deflection.
 - f. Move the CH 2 input test setup to the CH 1 input.
 - g. Set the CH 1 INPUT COUPLING switch to DC, CH 2 INPUT COUPLING switch to GND, CH 1 VOLTS/DIV switch to 0.2 V.
 - h. Adjust the Medium-Frequency signal generator for a 2 division display of a 25 megahertz signal.
 - i. Set VERT MODE switch to CH 2.
 - j. CHECK - CRT display for no more than 0.2 division of deflection.
 - k. Disconnect the test setup.

36. Check Common Mode Rejection Ratio
 - a. Set both VOLTS/DIV switches to 5 mV, both INPUT COUPLING switches to DC, the VERT MODE switch to CH 1, and push the CH 2 INVERT switch.
 - b. Connect the output of the Medium-Frequency Constant-Amplitude Signal Generator (Type 191) to the CH 1 and 2 inputs via a GR-to-BNC adapter, 42-inch 50 Ω BNC cable, X10 BNC attenuator, 50 Ω BNC termination, and a dual input coupler.
 - c. Adjust the Medium-Frequency signal generator for a six division display of a 50 kHz signal.
 - d. Set the VERT MODE switch to ADD.
 - e. Increase output frequency of the Medium-Frequency signal generator to 20 MHz.
 - f. Note the amount of vertical deflection for use in step 36-h.
 - g. Set the VERT MODE switch to CH 1.
 - h. CHECK - That the amount of vertical deflection is at least 10 times that noted in step 36-f.
 - i. Release the CH 2 INVERT switch and disconnect the test setup.

37. Check Bandwidth Limit Operation
 - a. Pull the 20 MHz BW/TRIG VIEW button to BW and set the CH 1 INPUT COUPLING switch to DC.

- b. Connect the Medium-Frequency Constant-Amplitude Signal Generator (Type 191) to the CH 1 input via 42-inch 50 Ω BNC cable and a 50 Ω BNC termination.
- c. Adjust the Medium-Frequency signal generator for a six division display of a 50 kilohertz signal.
- d. Increase the output frequency of the signal generator until the display is reduced to 4.2 divisions.
- e. CHECK - Output frequency of the signal generator is between 16 and 24 megahertz.
- f. Disconnect the test setup.

ELECTRICAL PARTS LIST

Replacement parts should be ordered from the Tektronix Field Office or Representative in your area. Changes to Tektronix products give you the benefit of improved circuits and components. Please include the instrument type number and serial number with each order for parts or service.

ABBREVIATIONS AND REFERENCE DESIGNATORS

| | | |
|--|---|---|
| <p>A Assembly, separable or repairable</p> <p>AT Attenuator, fixed or variable</p> <p>B Motor</p> <p>BT Battery</p> <p>C Capacitor, fixed or variable</p> <p>Cer Ceramic</p> <p>CR Diode, signal or rectifier</p> <p>CRT cathode-ray tube</p> <p>DL Delay line</p> <p>DS Indicating device (lamp)</p> <p>Elect. Electrolytic</p> <p>EMC electrolytic, metal cased</p> <p>EMT electrolytic, metal tubular</p> <p>F Fuse</p> | <p>FL Filter</p> <p>H Heat dissipating device (heat sink, etc.)</p> <p>HR Heater</p> <p>J Connector, stationary portion</p> <p>K Relay</p> <p>L Inductor, fixed or variable</p> <p>LR Inductor/resistor combination</p> <p>M Meter</p> <p>Q Transistor or silicon-controlled rectifier</p> <p>P Connector, movable portion</p> <p>PMC Paper, metal cased</p> <p>PT paper, tubular</p> | <p>PTM paper or plastic, tubular molded</p> <p>R Resistor, fixed or variable</p> <p>RT Thermistor</p> <p>S Switch</p> <p>T Transformer</p> <p>TP Test point</p> <p>U Assembly, inseparable or non-repairable</p> <p>V Electron tube</p> <p>Var Variable</p> <p>VR Voltage regulator (zener diode, etc.)</p> <p>WW wire-wound</p> <p>Y Crystal</p> |
|--|---|---|

| Ckt. No. | Tektronix Part No. | Serial/Model No. Eff | No. Disc | Description |
|------------|--------------------|----------------------|----------|-------------------------------------|
| ASSEMBLY | | | | |
| | 670-3023-00 | XB040000 | | OUTPUT Circuit Board Assembly |
| CAPACITORS | | | | |
| C402 | 283-0032-00 | | | 470 pF, Cer, 500 V, 5% |
| C412 | 283-0032-00 | | | 470 pF, Cer, 500 V, 5% |
| C422 | 281-0139-00 | | | 2.5-9 pF, Var, Cer, 100 V |
| C425 | 281-0638-00 | | | 240 pF, Cer, 500 V, 5% |
| C426 | 281-0580-00 | | | 470 pF, Cer, 500 V, 10% |
| C427 | 281-0524-00 | | | 150 pF, Cer, 500 V, 20% |
| C430 | 283-0000-00 | | | 0.001 μ F, Cer, 500 V, +100%-0% |
| C432 | 283-0065-00 | | | 0.001 μ F, Cer, 100 V, 5% |
| C437 | 281-0629-00 | | | 33 pF, Cer, 600 V, 5% |
| C438 | 281-0123-00 | | | 5-25 pF, Var, Cer, 100 V |
| C439 | 281-0617-00 | | | 15 pF, Cer, 200 V, 10% |
| C442 | 283-0065-00 | | | 0.001 μ F, Cer, 100 V, 5% |
| C444 | 281-0651-00 | | | 47 pF, Cer, 200 V, 5% |
| C469 | 281-0500-00 | | | 2.2 pF, Cer, 500 V, ± 0.5 pF |
| C481 | 283-0032-00 | | | 470 pF, Cer, 500 V, 5% |
| C482 | 283-0000-00 | | | 0.001 μ F, Cer, 500 V, +100%-0% |
| C485 | 283-0003-00 | | | 0.01 μ F, Cer, 150 V, +80%-20% |
| C491 | 283-0032-00 | | | 470 pF, Cer, 500 V, 5% |
| C492 | 283-0000-00 | | | 0.001 μ F, Cer, 500 V, +100%-0% |
| C498 | 290-0523-00 | | | 2.2 μ F, Elect., 20 V, 20% |
| C499 | 290-0523-00 | | | 2.2 μ F, Elect., 20 V, 20% |

ELECTRICAL PARTS LIST (cont)

| Ckt. No. | Tektronix Part No. | Serial/Model No. Eff | Disc | Description |
|-------------|--------------------|----------------------|------|--|
| DIODES | | | | |
| CR434 | 152-0422-00 | | | Silicon, VVC, PG1084 |
| CR451 | 152-0141-02 | | | Silicon, 1N4152 |
| CR452 | 152-0141-02 | | | Silicon, 1N4152 |
| VR464 | 152-0195-00 | | | Zener, selected from 1N751A, 0.4 W, 5.1 V, 5% |
| VR481,VR491 | 152-0395-00 | XB060000 | | Zener, 1N749A, 0.4 W, 4.3 V, 5% |
| INDUCTORS | | | | |
| L464 | 108-0570-00 | | | 75 nH |
| L474 | 108-0570-00 | | | 75 nH |
| L498 | 108-0440-00 | | | 8 μ H |
| L499 | 108-0440-00 | | | 8 μ H |
| LR483 | 108-0328-00 | | | 0.3 μ H (wound on a 220 Ω , 1/4 W, 5% resistor) |
| LR493 | 108-0328-00 | | | 0.3 μ H (wound on a 220 Ω , 1/4 W, 5% resistor) |
| RESISTORS | | | | |
| R401 | 321-0068-00 | | | 49.9 Ω , 1/8 W, 1% |
| R402 | 315-0221-00 | | | 220 Ω , 1/4 W, 5% |
| R403 | 321-0097-00 | | | 100 Ω , 1/8 W, 1% |
| R404 | 321-0097-00 | | | 100 Ω , 1/8 W, 1% |
| R406 | 315-0242-00 | | | 2.4 k Ω , 1/4 W, 5% |
| R408 | 321-0121-00 | | | 178 Ω , 1/8 W, 1% |
| R409 | 321-0189-00 | | | 909 Ω , 1/8 W, 1% |
| R411 | 321-0068-00 | | | 49.9 Ω , 1/8 W, 1% |
| R412 | 315-0221-00 | | | 220 Ω , 1/4 W, 5% |
| R413 | 321-0097-00 | | | 100 Ω , 1/8 W, 1% |
| R414 | 321-0097-00 | | | 100 Ω , 1/8 W, 1% |
| R416 | 315-0242-00 | | | 2.4 k Ω , 1/4 W, 5% |
| R418 | 311-1237-00 | | | 1 k Ω , Var |
| R419 | 321-0189-00 | | | 909 Ω , 1/8 W, 1% |
| R421 | 321-0089-00 | | | 82.5 Ω , 1/8 W, 1% |
| R422 | 311-1278-00 | | | 250 Ω , Var |
| R423 | 315-0101-00 | | | 100 Ω , 1/4 W, 5% |
| R424 | 315-0101-00 | | | 100 Ω , 1/4 W, 5% |
| R425 | 311-1238-00 | | | 5 k Ω , Var |
| R426 | 311-1228-00 | | | 10 k Ω , Var |
| R427 | 311-1225-00 | | | 1 k Ω , Var |
| R430 | 323-0159-00 | | | 442 Ω , 1/2 W, 1% |
| R431 | 317-0220-00 | | | 22 Ω , 1/8 W, 5% |
| R432 | 315-0131-00 | | | 130 Ω , 1/4 W, 5% |
| R433 | 323-0118-00 | | | 165 Ω , 1/2 W, 1% |
| R434 | 315-0100-00 | | | 10 Ω , 1/4 W, 5% |
| R435 | 321-0059-00 | | | 40.2 Ω , 1/8 W, 1% |
| R436 | 317-0100-00 | | | 10 Ω , 1/8 W, 5% |
| R437 | 317-0561-00 | | | 560 Ω , 1/8 W, 5% |
| R438 | 311-1260-00 | | | 250 Ω , Var |
| R440 | 323-0159-00 | | | 442 Ω , 1/2 W, 1% |
| R441 | 317-0220-00 | | | 22 Ω , 1/8 W, 5% |
| R442 | 315-0131-00 | | | 130 Ω , 1/4 W, 5% |

ELECTRICAL PARTS LIST (cont)

| Ckt. No. | Tektronix Part No. | Serial/Model No. Eff | Disc | Description |
|------------------|--------------------|----------------------|------|------------------------------------|
| RESISTORS (cont) | | | | |
| R443 | 323-0118-00 | | | 165 Ω , 1/2 W, 1% |
| R444 | 315-0100-00 | | | 10 Ω , 1/4 W, 5% |
| R445 | 321-0059-00 | | | 40.2 Ω , 1/8 W, 1% |
| R448 | 315-0622-00 | | | 6.2 k Ω , 1/4 W, 5% |
| RT448 | 307-0181-00 | | | 100 k Ω , Thermal |
| R449 | 321-0193-00 | | | 1 k Ω , 1/8 W, 1% |
| R451 | 315-0820-00 | | | 82 Ω , 1/4 W, 5% |
| R452 | 315-0301-00 | | | 300 Ω , 1/4 W, 5% |
| R453 | 323-0157-00 | | | 422 Ω , 1/2 W, 1% |
| R462 | 321-0205-00 | | | 1.33 k Ω , 1/8 W, 1% |
| R463 | 321-0219-00 | | | 1.87 k Ω , 1/8 W, 1% |
| R464 | 321-0093-00 | | | 90.9 Ω , 1/8 W, 1% |
| R465 | 321-0126-00 | | | 200 Ω , 1/8 W, 1% |
| R466 | 311-1226-00 | | | 2.5 k Ω , Var |
| R468 | 321-0031-00 | | | 20.5 Ω , 1/8 W, 1% |
| R469 | 323-0072-00 | | | 54.9 Ω , 1/2 W, 1% |
| R474 | 321-0093-00 | | | 90.9 Ω , 1/8 W, 1% |
| R475 | 321-0126-00 | | | 200 Ω , 1/8 W, 1% |
| R478 | 321-0031-00 | | | 20.5 Ω , 1/8 W, 1% |
| R480 | 315-0100-00 | | | 10 Ω , 1/4 W, 5% |
| R481 | 315-0820-00 | | | 82 Ω , 1/4 W, 5% |
| R482 | 315-0820-00 | | | 82 Ω , 1/4 W, 5% |
| R483 | 310-0700-00 | | | 430 Ω , 4 W, WW, 1% |
| R485 | 301-0100-00 | | | 10 Ω , 1/2 W, 5% |
| R491 | 315-0820-00 | | | 82 Ω , 1/4 W, 5% |
| R492 | 315-0820-00 | | | 82 Ω , 1/4 W, 5% |
| R493 | 310-0700-00 | | | 430 Ω , 4 W, WW, 1% |
| R498 | 315-0100-00 | | | 10 Ω , 1/4 W, 5% |
| R499 | 315-0100-00 | | | 10 Ω , 1/4 W, 5% |
| TRANSISTORS | | | | |
| Q402 | 151-0212-00 | | | Silicon, NPN, selected from A485 |
| Q406 | 151-0212-00 | | | Silicon, NPN, selected from A485 |
| Q412 | 151-0212-00 | | | Silicon, NPN, selected from A485 |
| Q416 | 151-0212-00 | | | Silicon, NPN, selected from A485 |
| Q432 | 151-0212-00 | | | Silicon, NPN, selected from A485 |
| Q442 | 151-0212-00 | | | Silicon, NPN, selected from A485 |
| Q462 | 151-0434-00 | | | Silicon, PNP, 2N4261 |
| Q468 | 151-0222-00 | | | Silicon, NPN, selected from 2N4251 |
| Q472 | 151-0434-00 | | | Silicon, PNP, 2N4261 |
| Q478 | 151-0222-00 | | | Silicon, NPN, selected from 2N4251 |
| Q482 | 151-0446-00 | | | Silicon, NPN, selected from 2N3866 |
| Q492 | 151-0446-00 | | | Silicon, NPN, selected from 2N3866 |

MECHANICAL PARTS LIST

Replacement parts should be ordered from the Tektronix Field Office or Representative in your area. Changes to Tektronix products give you the benefit of improved circuits and components. Please include the instrument type number and serial number with each order for parts or service.

ABBREVIATIONS

| | | | | | |
|--------|----------------------|------|------------------|-----|------------------|
| BHB | binding head brass | h | height or high | OHB | oval head brass |
| BHS | binding head steel | hex. | hexagonal | OHS | oval head steel |
| CRT | cathode-ray tube | HHB | hex head brass | PHB | pan head brass |
| csk | countersunk | HHS | hex head steel | PHS | pan head steel |
| DE | double end | HSB | hex socket brass | RHS | round head steel |
| FHB | flat head brass | HSS | hex socket steel | SE | single end |
| FHS | flat head steel | ID | inside diameter | THB | truss head brass |
| Fil HB | fillister head brass | lg | length or long | THS | truss head steel |
| Fil HS | fillister head steel | OD | outside diameter | w | wide or width |

| Fig. & Index No. | Tektronix Part No. | Serial/Model No. | | Q † y | Description |
|------------------------|-----------------------|------------------|------|-------------|--|
| | | Eff | Disc | | |
| | | | | 1 | CIRCUIT BOARD ASSEMBLY--OUTPUT |
| | | | | | circuit board assembly includes: |
| | 131-9608-00 | | | 4 | TERMINAL, pin, 0.365 inch long |
| | 136-0252-01 | | | 2 | SOCKET, pin connector, 0.178 inch long |
| | 136-0252-04 | | | 31 | SOCKET, pin connector, 0.178 inch long |
| | 129-0106-00 | | | 1 | POST, metallic |
| | 131-0761-00 | | | 1 | TERMINAL POST |
| | 214-1138-00 | | | 2 | HEATSINK |
| | 214-0368-00 | | | 2 | SPRING, heatsink |
| | 343-0097-00 | | | 2 | CLAMP, transistor, heatsink, plastic |
| | 352-0062-00 | | | 2 | HOLDER, transistor, heatsink, plastic |
| | 407-1389-00 | | | 1 | BRACKET, heatsink |
| | 211-0130-00 | | | 2 | SCREW, 4-40 x 0.25 inch, HSS |
| | 211-0033-00 | | | 4 | SCREW, 4-40 x 0.312 inch, PHS |
| | 211-0012-00 | | | 4 | SCREW, 4-40 x 0.375 inch, PHS |
| | 210-0627-00 | | | 2 | RIVET |
| | 210-0004-00 | | | 6 | WASHER, lock, internal, #4 |
| | 210-0599-00 | | | 4 | NUT, sleeve |
| | 210-0406-00 | | | 8 | NUT, hex., 4-40 x 0.188 inch |

¹Refer to Electrical Parts List for part number.

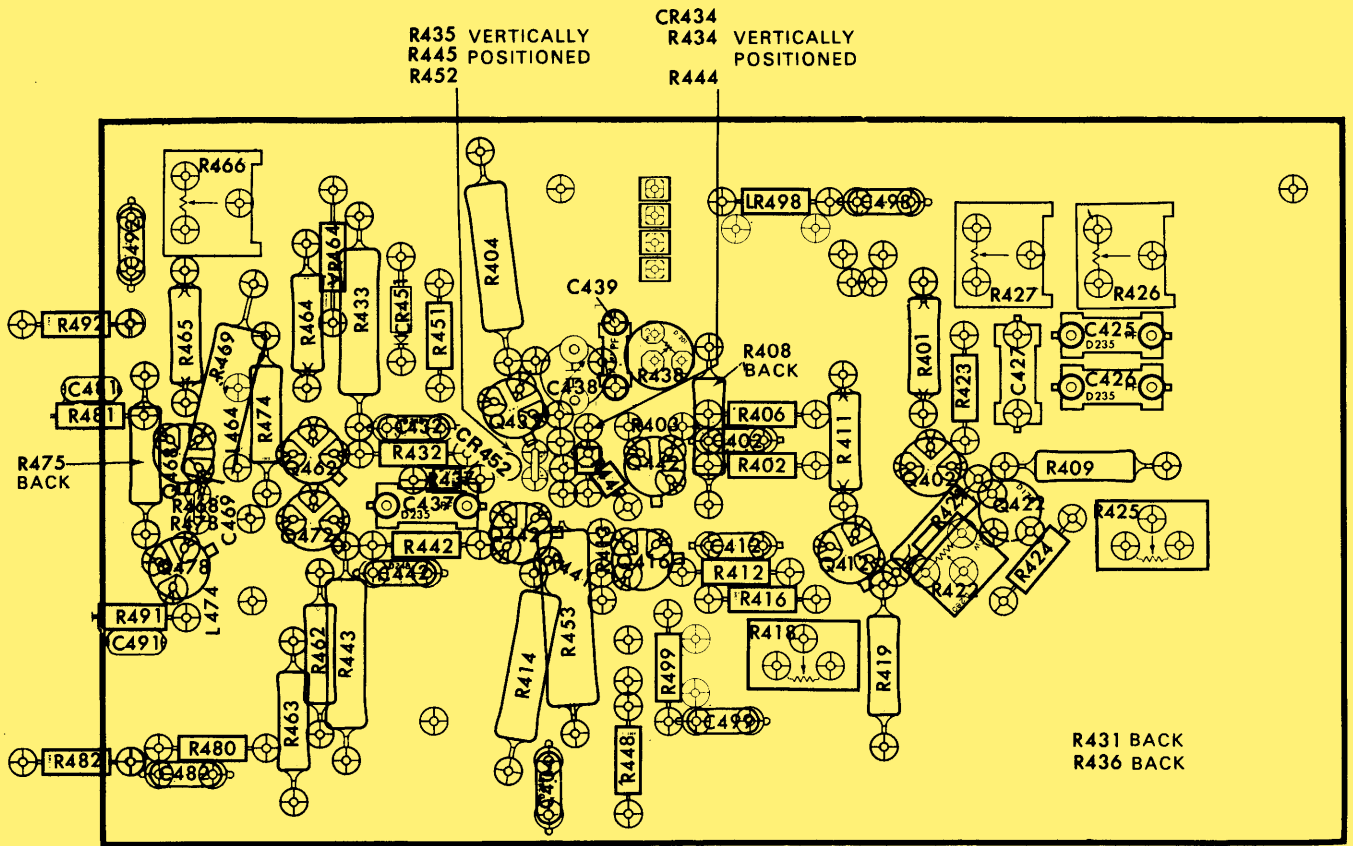
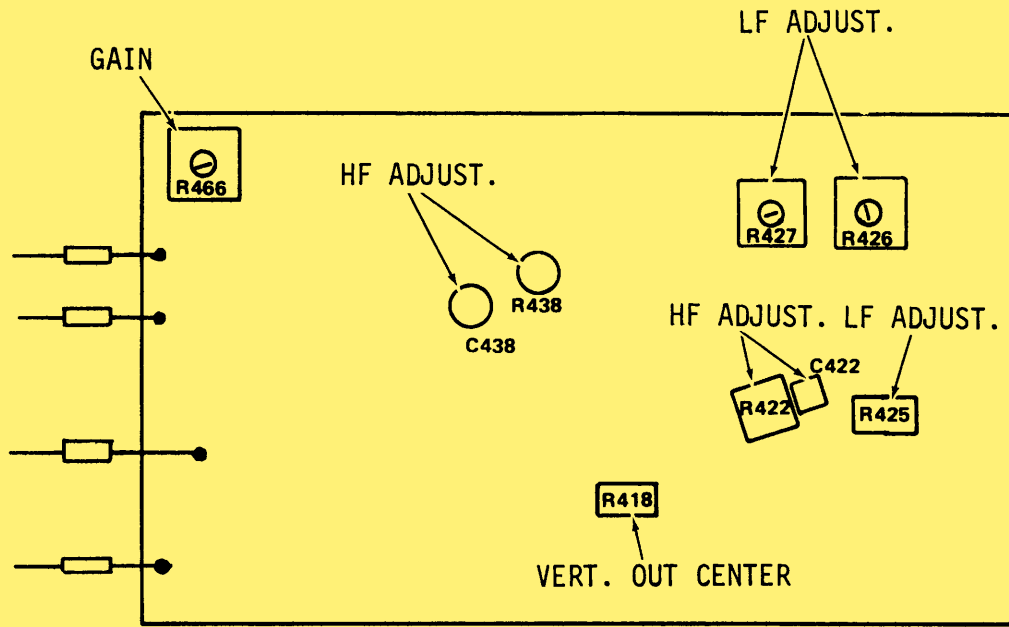



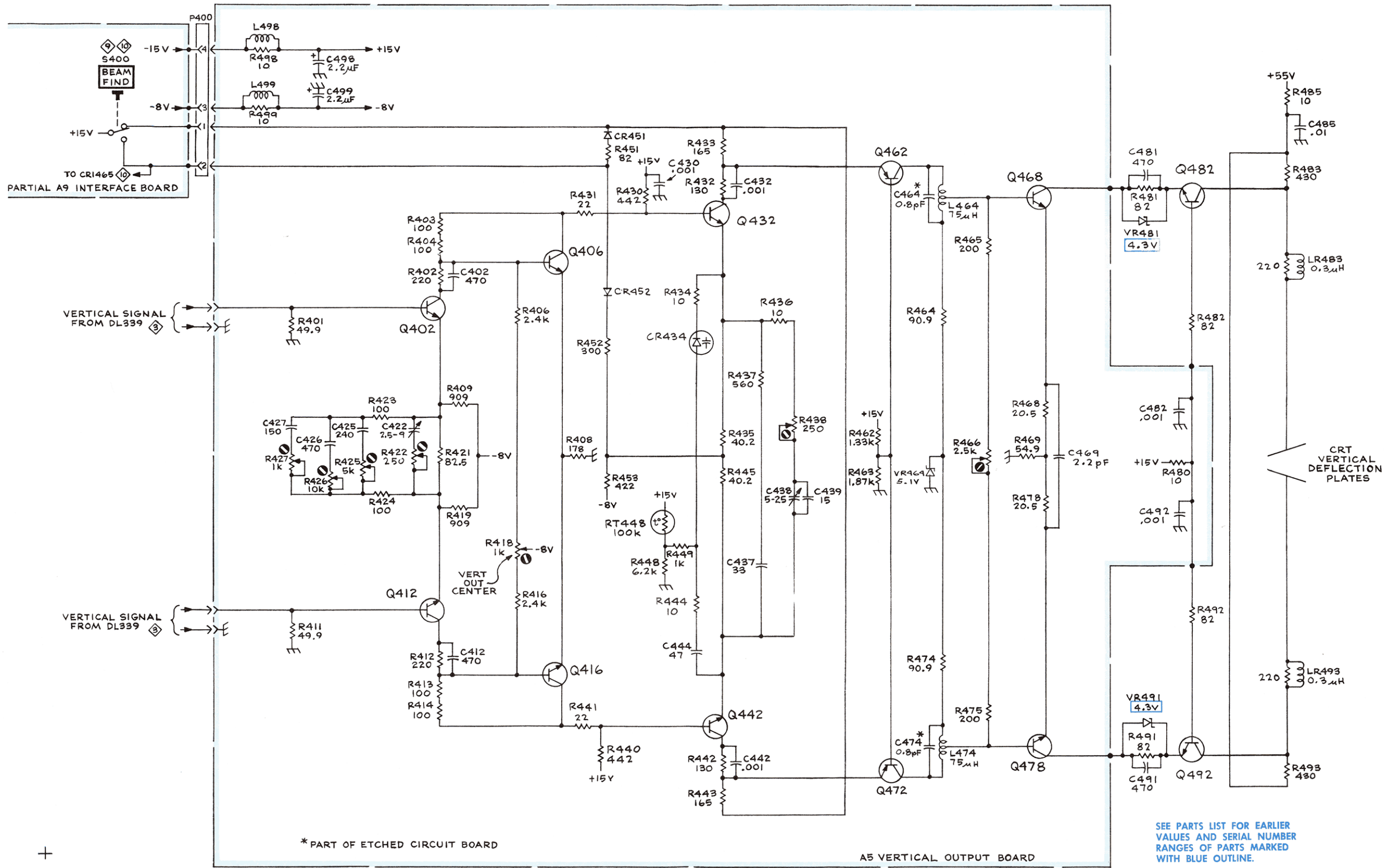

465 OSCILLOSCOPE

(B)

VERTICAL OUTPUT AMPLIFIER (B040000 AND UP) M20159

1.43

AMPLIFIER B040000 & UP M20159

ELECTRICAL PARTS LIST AND SCHEMATIC CORRECTION

CHANGE TO:

| | | |
|-------|-------------|---|
| C481 | 283-0077-00 | 330 pF, Cer, 500 V |
| C491 | 283-0077-00 | 330 pF, Cer, 500 V |
| C676 | 281-0549-00 | 68 pF, (nominal value) selected |
| VR481 | 152-0195-00 | Zener, selected from 1N751A, 0.4 W, 5.1 V, 5% |
| VR491 | 152-0195-00 | Zener, selected from 1N751A, 0.4 W, 5.1 V, 5% |
| R481 | 315-0101-00 | 100 Ω , 1/4 W, 5% |
| R491 | 315-0101-00 | 100 Ω , 1/4 W, 5% |

ADD:

| | | |
|------|-------------|--|
| C428 | 283-0220-00 | 0.01 μ F, Cer, 50 V |
| C678 | | 33 pF (nominal value) selected (Added when required) |
| R428 | 315-0123-00 | 12 k Ω , 1/4 W, 5% |

Add C428 (.01 μ F) and R428 (12K) in series between junction of C426/C427 and R426/R427 located on Vertical Output Amplifier B040000-up.

Add C678 (nominal value 33 pF) between emitters of Q678 and Q688.



465 EFF All Serial Numbers

For some selected Serial Number instruments the following value may be used for R1585.

| | | |
|-------|-------------|-----------------------------|
| R1585 | 321-0278-00 | 7.68 k Ω , 1/8 W, 1% |
|-------|-------------|-----------------------------|



ELECTRICAL PARTS LIST AND SCHEMATIC CORRECTION

CHANGE TO:

| | | |
|--------|-------------|---|
| C225 | 283-0004-00 | 0.02 μ F, Cer, 150 V (Installed in all instruments.) |
| C1339 | 283-0081-00 | 0.1 μ F, Cer, 25 V |
| VR1524 | 152-0508-00 | Zener, 0.4 W, 12.6 V, 5% |
| Q804 | 151-0199-00 | Silicon, PNP, MPS-3640 |
| Q854 | 151-0199-00 | Silicon, PNP, MPS-3640 |
| R122 | 311-1224-00 | 500 Ω , Var |
| R1448 | 315-0183-00 | 18 k Ω , 1/4 W, 5% |
| R1566 | 315-0471-00 | 470 Ω , 1/4 W, 5% |
| R1585 | 321-0278-00 | 7.68 k Ω , 1/8 W, 1% (7.68 k Ω value was used in some selected earlier SN instruments.) |

REMOVE:

| | | |
|-------|-------------|--------------------------------|
| C345 | 283-0004-00 | 0.02 μ F, Cer, 150 V |
| C354 | 290-0517-00 | 6.8 μ F, Elect., 35 V, 20% |
| C375 | 283-0004-00 | 0.02 μ F, Cer, 150 V |
| R1524 | 315-0202-00 | 2 k Ω , 1/4 W, 5% |

ADD:

| | | |
|--------|-------------|--------------------------------|
| C165 | 283-0004-00 | 0.02 μ F, Cer, 150 V |
| VR1523 | 152-0243-00 | Zener, 1N965B, 0.4 W, 15 V, 5% |
| R165 | 315-0331-00 | 330 Ω , 1/4 W, 5% |

C165 is added from Q164 collector to ground; R165 is added from Q164 collector to -8V. VR1523 replaces R1524.

MECHANICAL PARTS LIST CORRECTION

Page 8-4

| | | | | | | |
|------------|-------------|----------|---------|---|--------------------------|----------|
| Fig. 1-115 | 369-0031-00 | B010100 | B109999 | 1 | IMPELLER, fan w/setscrew | |
| | 369-0031-01 | B110000 | | 1 | IMPELLER, fan w/setscrew | |
| | 105-0507-00 | XB110000 | | 1 | STOP, end play | |
| | | | | | M20,515 | } C1/673 |
| | | | | | M20,012, M20,129, | |
| | | | | | M20,261, M20,385, | |
| | | | | | M20,393, M20,555, | |
| | | | | | | |

